



water & forestry

Department:
Water Affairs and Forestry
REPUBLIC OF SOUTH AFRICA

DIRECTORATE: RESOURCE DIRECTED MEASURES

**LETABA CATCHMENT
RESERVE DETERMINATION STUDY –
HYDROLOGY SUPPORT AND WATER RESOURCE
EVALUATION
FINAL
FEBRUARY 2006**

Prepared for:

Department of Water Affairs and Forestry
Harrison Pienaar
Directorate: Resource Directed Measures
Private Bag X313
Pretoria
1200

Prepared by:

Ken Haumann
P D Naidoo and Associates

Letaba Catchment Reserve Determination Hydrology support and water resource evaluation

i

TITLE Hydrology support and water resource evaluation
AUTHOR K Haumann
STUDY NAME Letaba Catchment Reserve Determination Study
REPORT STATUS Final
DATE February 2006
DWAF REPORT NO. RDM/B800/01/CON/COMP/1104

APPROVED FOR PULLES HOWARD & DE LANGE (INC)

.....
R. G. M. HEATH
PROJECT LEADER

APPROVED FOR TLOU & MALLORY ENGINEERING & MANAGEMENT SERVICES
(PTY) LTD.

.....
T. TLOU
PROJECT MANAGER

APPROVED FOR DEPARTMENT OF WATER AFFAIRS AND FORESTRY:
DIRECTORATE RESOURCE DIRECTED MEASURES

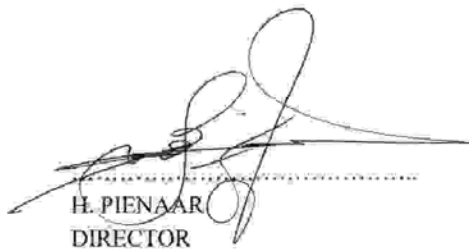
.....
H. PIENAAR
DIRECTOR

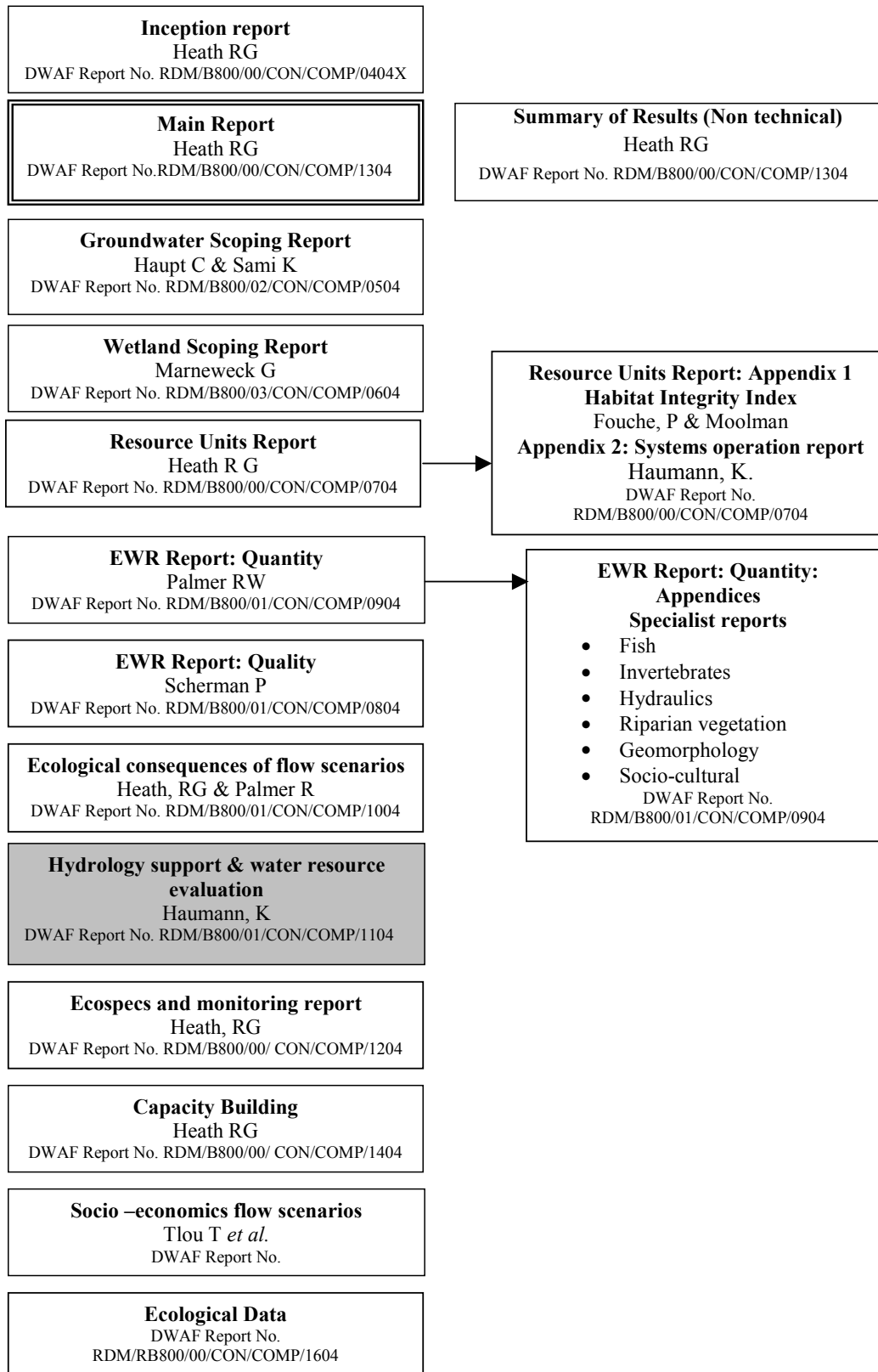

TABLE OF CONTENTS

1. INTRODUCTION	1
1.1 Background	1
1.2 Purpose of this Report	1
1.3 Study Area	1
2. OVERVIEW OF ANALYSIS	4
2.1 Overview	4
2.2 Use of Models	4
2.2.1 WRYM Model	4
2.2.2 Spatsim	5
3. HYDROLOGY	5
3.1 General	5
3.2 EWR sites	6
3.3 Hydrology at EWR sites	10
3.4 Present day Hydrology	11
3.5 Observed Hydrology	12
3.5.1 Conversion of monthly runoff to daily runoff	12
3.5.2 Instantaneous flow records	13
3.5.3 Levels of confidence : Hydrology	13
4. SYSTEM OPERATION	14
4.1 General Background	14
4.2 System Configuration for a comprehensive Letaba Water Resources analysis	15
4.3 System Demand	16
4.3.1 Domestic and industrial Demand	16
4.3.2 Irrigation Demands	16
4.3.3 Afforestation	18
4.3.4 Releases to Kruger National Park	18
4.3.5 International Obligations	18
4.3.6 Return flow and Losses in the system	19
4.3.7 Level of Confidence in Demands	19
4.4 Operation of Dams and Weirs	20
4.4.1 Dap Naude Dam	20
4.4.2 Ebenezer Dam	20
4.4.3 Magoebaskloof Dam	20
4.4.4 Tzaneen Dam	20
4.4.5 Middle Letaba Dam	21
4.4.6 Nsami Dam	21
4.4.7 Operation of weirs in the system	21
5. ECOLOGICAL WATER REQUIREMENTS	22
5.1 General Background	22
5.2 Desktop Reserve Parameter Selection	22
5.3 Flow-Stressor Response Modelling	22
5.4 Flood Requirements	27
5.4.1 High Flow Requirements at the EWR sites	27
6. OPERATIONAL SCENARIO MODELLING	35
6.1 Scenario Description	35
6.1.1 Scenario 1	35
6.1.2 Scenario 2	36

6.1.3 Scenario 3	36
6.1.4 Scenario 4	37
6.1.5 Scenario 5	38
6.1.6 Scenario 6	38
6.1.7 Scenario 7	38
6.1.8 Scenario 8	38
6.1.9 Scenario 9	39
6.1.10 Scenario 10	39
6.1.11 Scenario 11	40
6.1.12 Scenario 12	40
6.1.13 Scenario 13	41
6.1.14 scenario 14.....	41
6.2 Impact of Scenarios on Water Supply	42
6.2.1 Impact on Subsystem Upstream of Tzaneen Dam	42
6.2.2 Impact Downstream of Tzaneen up to Confluence of Middle and Klein Letaba.....	44
6.2.3 Letsitele and Nwanedzi Subcatchment	45
6.2.4 Middle and Klein Letaba subcatchment	46
7. SUMMARY	48
8. REFERENCES	51

The following Appendices are contained in electronic format on the CD inside the back cover

APPENDIX A: Extending the Letaba Hydrology for two selected Quaternary Catchments : Report

APPENDIX B: Optimised scenario flow duration curves per month

APPENDIX C: This Appendix is supplied in electronic format (DWAf report no. RDM/B800/00/CON/COMP/1604) and contains the following data for each EWR site:

**Configuration Layout of Letaba Catchment for Water Resources Yield Model
(AutoCad format)**

Daily Flow Duration Curves for each month of the year

Time Series of Natural and Present Day Monthly Flows

Parameters used in the Spatsim Desktop Reserve Model

Log of modifications to the Desktop Reserve Data

.tab and .rul files generated by Spatsim Desktop Reserve Model

IFR File for the WRYM model

Scenario Duration Curves

1. INTRODUCTION

1.1 Background

The Letaba catchment is found in the Limpopo province. The catchment is part of the Luvuvhu/Letaba water management area. The whole Letaba catchment consists of three tertiary catchments, namely, B81, B82 and B83. This catchment is the major source of water supply to the Kruger National Park, which is one of the most important tourist attractions in South Africa.

This project was initiated to determine the flow requirements that are necessary for the maintenance of the ecological stability and diversity in the main reach and tributaries of Letaba River, as well as in the Kruger National Park.

PD Naidoo and Associates were responsible for the hydrology aspects of the project. This involved data acquisition, investigation into the level of confidence of available data, modelling of the data to determine the environmental water requirements (EWR), and undertaking system operating analysis of various scenarios in order to optimise the environmental water requirements.

During the course of this project, the following work has been accomplished:

- A pilot project (on Tertiary Catchment B82) was undertaken to evaluate the effect on the hydrology of extending the virgin data flow beyond 1995. (see Appendix A)
- Ecological water requirements for seven EWR sites in the system have been generated for various ecological categories.
- More than fourteen scenarios have been analysed to investigate the impact of various combinations of water releases for ecology

1.2 Purpose of this Report

The main objective of this report is to summarise the hydrology and related methodology used to investigate the impacts of ecological flow releases on the Letaba water supply system for the supply of ecological water requirements. The impact of various scenarios of ecological releases have been assessed to select an optimised scenario that can meet the ecological requirements while minimising the impacts on other users in an already stressed water system.

1.3 Study Area

The study area in this project comprises the entire Letaba catchment. This catchment consists of three tertiary catchments, B81, B82 and B83 as shown in Figure 1.1. Tertiary catchment B81 consists of six quaternary catchments with total a catchment area of 4 952 square kilometres flowing into the Groot Letaba River.¹ Major economic activities take place in this tertiary catchment. Most of the water in the system is generated in this tertiary catchment.

Tertiary catchment B82 drains to the Middle and Klein Letaba rivers, which are the major tributaries of the Letaba River. The total catchment area of B82 tertiary catchment is 5 453 square kilometres.¹

The lower catchment , tertiary catchment B83, comprises a 3 264 square kilometre area.¹ Little economic activity takes place in this tertiary catchment. This tertiary catchment is mainly characterised by natural conservation areas and game ranching, such as the Kruger National Park.

Letaba Catchment

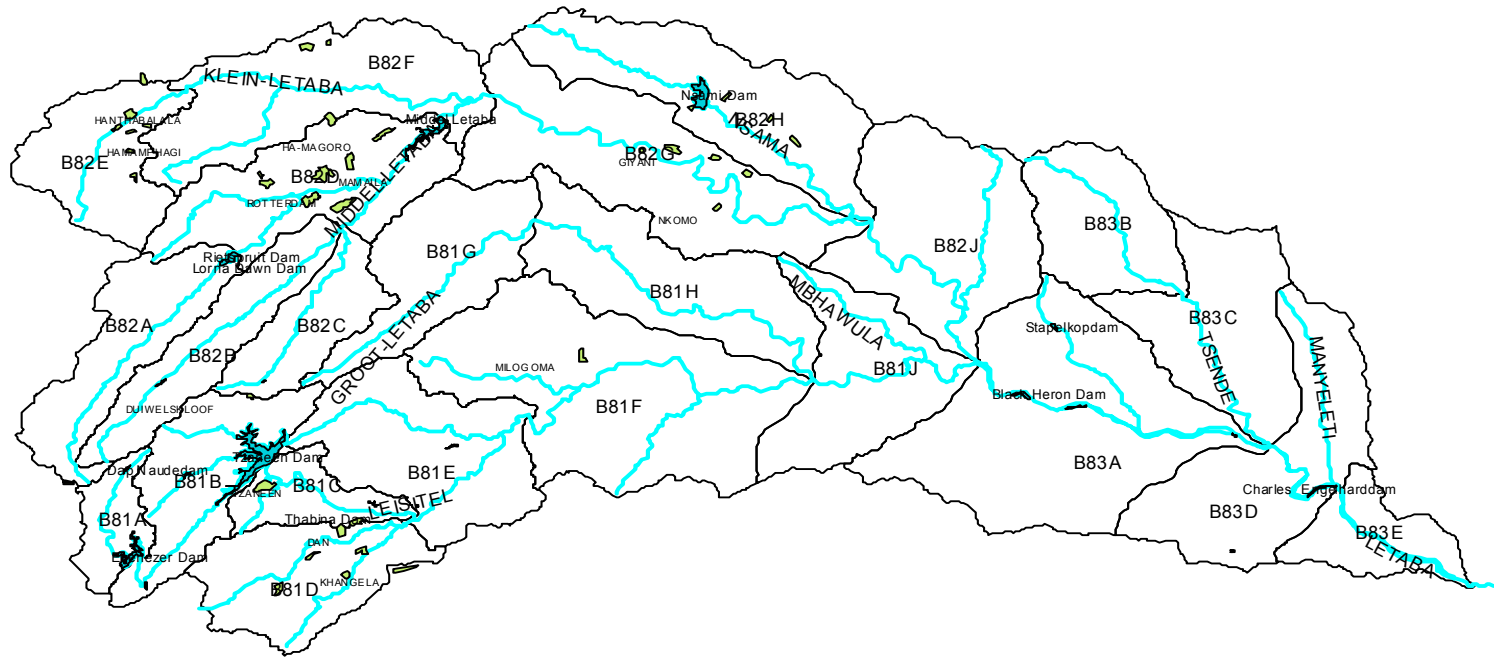
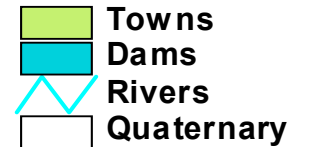

Figure 1.1: The Letaba Catchment showing Quaternary Sub-catchments



60 0 60 Kilometers



2. OVERVIEW OF ANALYSIS

2.1 Overview

For analysis purposes, the Water Resources Yield Model (WRYM) and the spatial and time series information model, Spatsim, have been used. The WRYM was set up to model the water resources system in the catchment, in order to convert virgin flows into present day flows and to assess the impact of environmental releases, under various supply scenarios, on the other demands in the system. Spatsim, using the output from WRYM, was used to generate time series data of the EWR as well as to generate duration and stress response curves required to investigate whether the EWR demands are met.

2.2 Use of Models

2.2.1 WRYM Model

Comprehensive analysis of the Letaba water resources system was undertaken using the Water Resources Yield model (WRYM). WRYM is a network model which uses a sophisticated network solver to analyse complex water systems. The WRYM model was developed based on the assumption that a water resources system can be represented by a flow network. In the model, water resources supply and demands are represented using nodes and links. Virgin (natural) monthly flows are the primary input into the model. The model allocates the various losses and demands in the system and generates monthly “present day” flows. The allocation of specific demands in the system is achieved through the allotment of penalties, where the highest penalty demand receives first priority in the allocation of supply.

The model takes account of :

- Monthly virgin (natural) flow at nodes
- Diffuse irrigation and afforestation
- Precipitation at and evaporation from reservoirs
- Specified demands (domestic, agriculture and industry)
- Losses in channels
- Water flow in natural channels, diversion channels and minimum flow channels

The model generates monthly time series data of :

- stream flow for each requested channel
- reservoir level
- reservoir volume
- yield of the entire system or subsystem
- assurance level for various target demands

The WRYM system configuration for the Groot Letaba, as developed during the Feasibility Study of the Groot Letaba Water Resource Development ², was adopted in this analysis with minor revisions, i.e. introducing nodes at each of the EWR sites. The Middle and Klein Letaba model, developed by DWAF in the 1990's, during an internal study on the Middle Letaba and Nsami Dams (unpublished), was appended to the Groot Letaba model. The demands for the Middle Letaba were updated in the combined model from data gathered during a situation assessment study carried out for DWAF in 2003 ³. A copy of the model configuration is included as Appendix B. This combined model was then initially used to convert virgin monthly flows into

present day monthly flows at each of the EWR sites, taking all demands, other than ecological water requirements, into account.

The time series of the ecological flow requirements, as determined using Spatsim as described below, were then used to generate a WRYM input file, so that the ecological demands could be simulated as a maximum priority demand in WRYM. The channel downstream of each EWR site, rather than the EWR channel itself, was used to represent each resource unit in the river system. Under a range of supply scenarios, the flow time series, generated with the WRYM model for channels downstream of EWR sites, were imported back into Spatsim in order to generate flow duration and stress response curves which were used to determine whether the ecological flow requirements in each resource unit were met.

2.2.2 Spatsim

The spatial and time series information model, Spatsim, has been used to generate the ecological water requirements at seven sites in the catchment for various ecological categories. Spatsim is an integrated, GIS based, data management model which has been designed to allow the efficient management, processing and modelling of hydrological data for a range of water resource assessment approaches in South Africa⁴.

Two of the integrated models in Spatsim, namely, the Desktop Reserve Model and the Stress/Flow and Risk Indicator Model have been used for the determination of the ecological water requirements. The Desktop Reserve Model has been calibrated for each quaternary catchment in the country and, based on virgin monthly flow and environmental management class, generates a first order estimate, in terms of monthly flow distributions, of ecological reserve at a particular site. These monthly flow distributions can be manipulated and altered to generate time series flow data to suit any particular set of flow requirements.

The Stress/Flow and Risk Indicator model, within Spatsim, uses Flow-Stressor Response methodology to determine the stress response of fish and invertebrates to a particular flow time series which has been generated by the Desktop Reserve Model, as described above. This model is used to fit the flow duration requirements to the criteria set by the specialists during the specialist workshop.

3. HYDROLOGY

3.1 General

The original terms of reference for the project assumed the use of available hydrology for the catchment and did not allow for any updating of the hydrology for the 23 quaternary catchments making up the Letaba Catchment. Available virgin flow data for the Letaba Catchment was limited to between 1920 and 1996 from the sources as shown in Table 3.1 below. However, in order to test the representivity of this data, a pilot project⁵ was initiated on two of the quaternaries, namely, B81D as a humid catchment and B83B as a dry catchment. The purpose of this pilot project was to extend the hydrology, by applying the more recent rainfall data to these two catchments and to assess the potential changes to the hydrology for the catchment as a whole. This was done using the WRSM2000 rainfall-runoff model. The conclusions drawn from the pilot project were:

- For the wetter catchment, there was a small (4%) increase in MAR, but a 20% increase in standard deviation of the MAR. This is attributed to the addition of generally wetter hydrological years of the late 90's, particularly the 1999/2000 year where the annual runoff was 6 times the average.
- For the dry catchment, there was a significant lowering of the MAR (36%) and a 15% standard deviation in MAR. This is attributed to the difference between the regionalised parameters used to generate the original WR90 series and the detailed calibration done in the pilot project, using flow gauge B8H011. The existing regionalised flows used in this project for B83D are considered to be a fairly poor representation of the hydrology of this catchment. However, the contributions by the dry catchments to flows in the Letaba are only around 7%. (Table 3.1)

The virgin flow input for the WRYM was restricted to the common series from 1925 to 1989 for the three tertiary catchments.

Table 3.1: Summarised hydrology of Tertiary catchment in Letaba

Tertiary Catchment	Available Hydrological data	MAR (m ³ x 10 ⁶)	% of Total MAR	Source
B81	1925-1992	381.0	66.36	Pre-Feasibility Study ⁶ (SRK/DWAF)
B82	1922-1996	151.9	26.45	Directorate of Hydrology (DWAF) (unpublished)
B83	1920-1989	41.3	7.19	Surface Water Resources of South Africa 1990 ¹ (SRK,WLPU, SSI)
Total		574.1	100	

As shown in the table above, more than 50% of the runoff in Letaba catchment generated in the tertiary catchment B81.

3.2 EWR sites

It is practically not possible to assess the ecological situation of a river at each and every point along the river. Therefore representative sites need to be selected, where the river health can be assessed and the ecological water requirements (EWR) of the river system can be determined. Selection of EWR sites in the Letaba river system was initiated in 1994 to complement the feasibility study for water resources development in the catchment.

In 1994 five sites were selected. The following procedures were adhered in selection of these sites:

- The locality of gauging weirs with good quality hydrological data
- The locality of the proposed developments
- The locality and characteristics of tributaries

- The habitat integrity/conservation status of the different river reaches
- The reaches where social communities depend on a healthy river ecosystem
- The suitability of the sites for follow-up monitoring
- The habitat diversity for aquatic organisms, marginal and riparian vegetation
- suitability of the sites for accurate hydraulic modelling throughout the range of flow, especially low flows.
- Accessibility of the sites.

Some adjustments were made in 1996 and again during this project, with regard to the actual location of the EWR sites, in consideration of the hydraulics at representative cross-sections. An additional two sites, one between Ebenezer and Tzaneen Dams on the Groot Letaba river and the other, downstream of the confluence of the Middle and Klein Letaba rivers, were selected during this project.

Location of the seven EWR sites in Letaba catchment is shown in Figure 3.1 below.

EWR SITES IN LETABA CATCHMENT

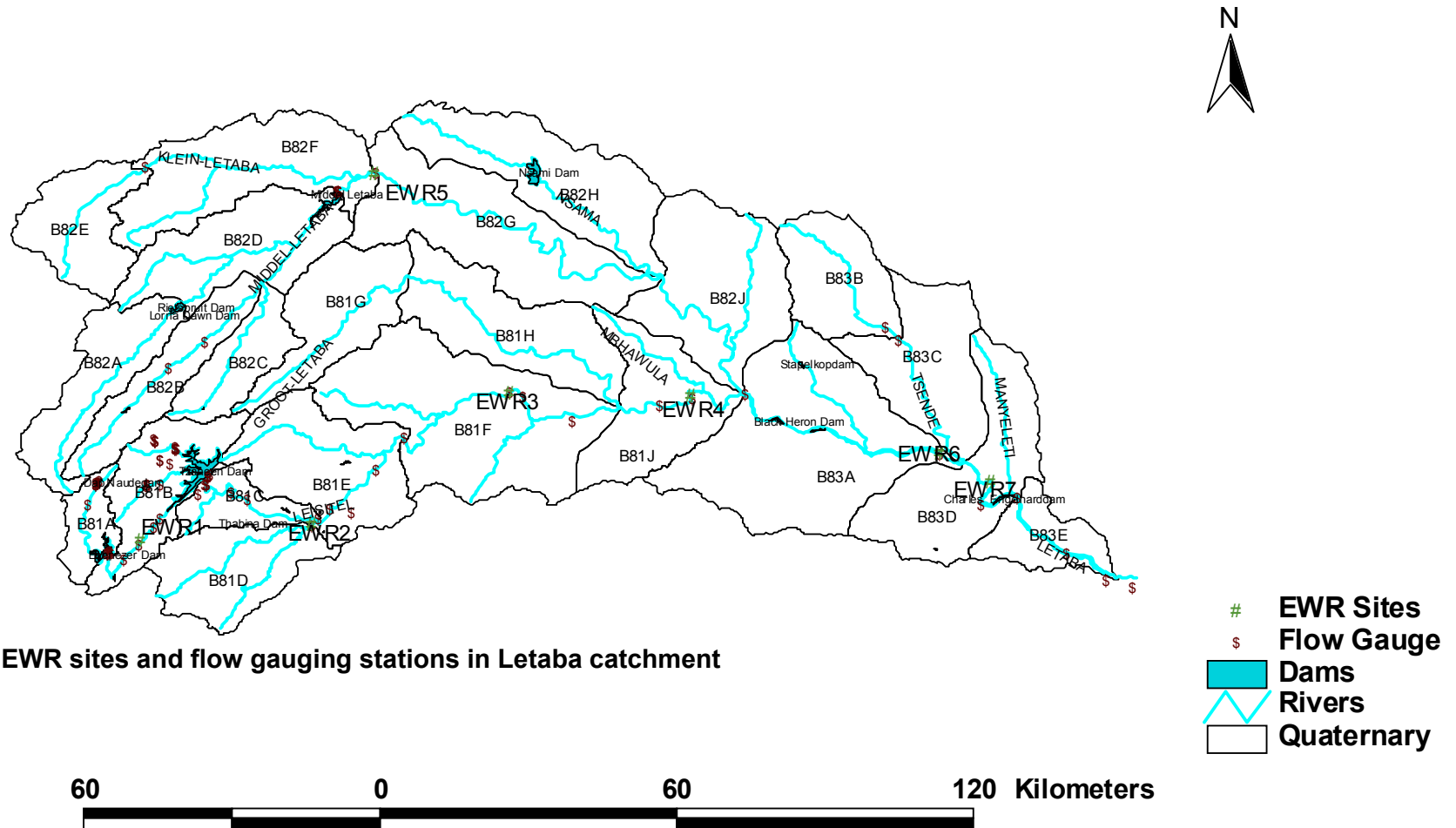

Figure 3.1: EWR sites and flow gauging stations in Letaba catchment

3.3 Hydrology at EWR sites

Each quaternary catchment was split into relevant sub-catchments in order to apportion natural runoff at the individual EWR sites. Using this virgin flow data, the WRYM was used to generate the present day hydrology at each EWR site. Table 3.2 shows a brief summary of sub-catchments contributing to EWR sites and natural and present mean annual runoff at each EWR sites:

Table 3.2: Summary of EWR Natural and Present Day Hydrology

EWR Site	Sub-catchment No.	Quaternary Catchment	Virgin MAR (10⁶ m³/a)	Present Day MAR(10⁶ m³/a)
EWR1	A10	B81A	15.4	
	A01A		22.5	
	A01B		11.03	
	B10	B81B	7.8	
	B12		6.54	
	0.828 B14		8.43	
Sub total			71.7	32.63
EWR2	D10	B81D	38.94	
	D13		5.89	
	D16		13.4	
	D20		7.14	
	D24		7.34	
	D28		11.93	
	D01		1.42	
Subtotal			86.06	63.30
EWR3		B81A	48.93	
		B81B	151.67	
		B81C	28.48	
		B81D	86.06	
		B81E	34.42	
		B81F	1.99	
	F30		6.06	
	F20		6.49	
Subtotal			364.1	109.41
EWR4		B81A	48.93	
		B81B	151.67	
		B81C	28.48	
		B81D	86.06	
		B81E	34.42	
		B81F	20.46	
		B81G	21.84	
		B81H	5.97	
		B81J	4.03	
Subtotal	BJ10		401.86	206.70
EWR5		B82A	19.7	
		B82B	15.2	
		B82C	12.40	
		B82D	13.70	

EWR Site	Sub-catchment No.	Quaternary Catchment	Virgin MAR (10 ⁶ m ³ /a)	Present Day MAR(10 ⁶ m ³ /a)
		B82E	11.0	
		B82F	23.1	
Subtotal			95.1	42.44
EWR6		B81A	48.93	
		B81B	151.67	
		B81C	28.48	
		B81D	86.06	
		B81E	34.42	
		B81F	20.46	
		B81G	21.84	
		B81H	5.97	
		B81J	6.43	
		B82A	19.7	
		B82B	15.2	
		B82C	12.40	
		B82D	13.70	
		B82E	11.0	
		B82F	23.1	
		B82G	14.1	
		B82H	10.7	
		B82J	13.5	
		B83A	12.8	
Subtotal			545.7	274.45
EWR7		B81A	48.93	
		B81B	151.67	
		B81C	28.48	
		B81D	86.06	
		B81E	34.42	
		B81F	20.46	
		B81G	21.84	
		B81H	5.97	
		B81J	6.43	
		B82A	19.7	
		B82B	15.2	
		B82C	12.40	
		B82D	13.70	
		B82E	11.0	
		B82F	23.1	
		B82G	14.1	
		B82H	10.7	
		B82J	13.5	
		B83A	12.8	
		B83B	8.6	
		B83C	5.9	
		0. 14 B83D	1.372	
Subtotal			561.57	289.41

3.4 Present day Hydrology

Comparison of the natural and present flow in Table 3.2 gives clear indication of the impact of the water resources development on the system. Agriculture and domestic

use are the major demand sectors in the system. The decline in the present day flow, when compared to the natural flow, is mainly attributed to the large demand of irrigation in the Groot Letaba and Middle and Klein Letaba subcatchments.

At present there is 14.8 million cubic metres released annually to Kruger National Park from Tzaneen Dam. Of this, 6.06 million cubic metres is abstracted downstream for domestic use. The remaining 8.74 million cubic metres goes to the Kruger National Park. However, the present day flow stipulated in Table 3.2 above does not include this release.

3.5 Observed Hydrology

The location of flow gauging stations can be seen in Figure 3.1. In general, the flow gauging station network in the Letaba catchment is poor. Most of the stations are concentrated in the upper catchment.

Observed flow data can be used to undertake flood analysis in order to determine the high flood requirement of riparian ecology and geomorphology. However, in this study, because of the short period and low reliability, the observed data was mainly used to generate daily flow series from the monthly natural and present flows at each EWR site.

Table 3.3: Flow gauging stations closest to EWR sites and stations used for hydrological analysis

EWR Sites	Closest Gauging Station	Station used to Disaggregate *
EWR1	B8H004	
EWR2	B8H010	B8H010
EWR3	B8H017	BH008
EWR4	B8H008	BH008
EWR5	B8H033	
EWR6	B8H029	BH008
EWR7	B8H018	

*stations used to disaggregate monthly flow to daily flow

Table 3.4: Flow Gauge Stations in the Catchment

Station	Period		Total Years	Incomplete Years	Remark
	Start	End			
B8H004	1948	1960	12		Short period
B8H010	1960	2002	42		
B8H017	1977	2002	35		Low flows not reliable
B8H008	1959	2003	44		
B8H033	1996	2000	4		
B8H029	None	None			
B8H018	1984	2002	18		

3.5.1 Conversion of monthly runoff to daily runoff

The geomorphologist required daily flow data for modelling purposes. Unfortunately, daily virgin and present day flows were unavailable and observed daily flows were limited. Daily runoff data was therefore generated, for both natural and present day hydrology, based on monthly time series data and the distribution curves of available daily observed data.

Each observed daily flow in a month was expressed as percentage of total monthly flow in each year of observed record. These daily percentage values were then sorted in descending order for each of 12 months. These values were then plotted as a distribution curve of percentage of monthly flow versus frequency (percentage of exceedance) for each of the twelve months. These distribution curves were then applied to each of the monthly natural and present day flows at each EWR site to generate the equivalent time series of natural and present day daily data for each site.

See Appendix C for duration curves of daily flow for each month in a year.

3.5.2 Instantaneous flow records

Most of gauging stations, if not all, in the Letaba catchment measure the daily average runoff. The instantaneous peak flow is obscured in the daily average runoff. Instantaneous or peak flows are responsible for shaping the river geomorphology as well as for changing the riparian vegetation. A reduction in frequency and amount of peak flows results in terrestrialization (terrestrial vegetation encroachment). Thus hydrological analysis on peak flows is important to have a comprehensive understanding of how the riparian ecology can be impacted as a result of water resources development. In the observed daily flow records supplied by DWAF, there is an instantaneous maximum and minimum peak factor provided for each month of observed data. In an attempt to determine daily peaks, these factors were applied to both the observed maximum and minimum daily average, respectively, for the month and then proportioned to each of the remaining intermediate daily averages in the month, to provide daily peak values. Analysis of these values provided frequency of observed peak flows as called for by the specialists.

3.5.3 Levels of confidence : Hydrology

The level of confidence on generated hydrological data depends on the procedures, the input data and parameters used to generate the data. The natural incremental flow for this project was generated using the Pitman Model. The model uses empirical equations to generate monthly flow data from monthly rainfall data input as a percentage of mean annual precipitation. The rainfall input data was developed for each rainfall zone in South Africa using available actual monthly rainfall data in each rainfall zone. Thus distribution of rainfall gauging stations and the extent of available data determine the reliability of the generated hydrology.

The available generated data is more than ten years old and it does not include the latest hydrological events, such as the flood during February 2000. The pilot study⁵, undertaken to investigate the representivity of the available data, indicated that, on average, the hydrology in the wetter catchments has not changed much, in terms of mean annual runoff, but that the variability of the annual runoff has increased. This implies that there is potential for a greater variation in flow conditions from year to year without a marked change in the average flow condition over a long period. On

the other hand, confidence in the dry catchments is much lower, as a result of the outcome of the pilot study. However, the contribution of the dry catchments to the hydrology is considerably less. Table 3.5 below summaries the level of confidence in the hydrology used for this project.

Table 3.5: Level of Confidence in the Hydrology Used.

Tertiary Catchment	Name of River	Available Periods	Origin of Data	Confidence in existing data	Source of Data	MAR as a % of the Total
B81	Groot Letaba	1925-1992	Detailed assessment made in 1994	Medium (data ten years out of date)	Pre-feasibility Study ⁶ (SRK/DWAF)	66.3 %
B82	Middel and Klein Letaba	1922-1995	Intermediate assessment made in late 1990s	Medium to Low	Directorate of Hydrology (Unpublished) (DWAF)	26.5 %
B83	Lower Letaba	1920-1989	Regional assessment made in the early 1990s	Low	WR90 ¹ (WRC-SRK,WLPU, SSI)	7.2 %

4. SYSTEM OPERATION

4.1 General Background

A pre-feasibility study for water resources development in the Groot Letaba⁶ was undertaken in 1994. This study was further updated in 1995 during the feasibility stage². A detailed description of the Groot-Letaba system can be found in DWAF Report PB B810/00/0398, December 1998.

The Middle and Klein Letaba (B82) and the lower catchment (B83) have been assessed as part of the contribution of the Letaba catchment to Olifants river system.

The Letaba system consists of the following major dams:

Table 4.1: Major Dams in the Letaba Catchment

Dam	DWAF Number	Quaternary Catchment	FSC (Million M ³)	Use
Dap Naude	B8R006	B81A	1.94	Domestic Use
Ebenezer	B8R001	B81A	70	Domestic Use
Magoebaskloof	B8R003	B81B	4.91	Irrigation
Tzaneen Dam	B8R005	B81B	157.3	Irrigation
Hans Merensky	B8R002		1.256	Irrigation
Thabina		B81D	0.28	Irrigation
Lorna Dawn		B82A	11.748	Irrigation
Middle Letaba	B8R007	B82D	184.2	Irrigation
Nsami		B82H	29.46	Irrigation

4.2 System Configuration for a comprehensive Letaba Water Resources analysis

The Groot-Letaba water resources system that was configured during the feasibility study was adopted for this study with minor modification at the EWR sites. The Middle and Klein Letaba model, which was set up by DWAF, was joined at a node with the Groot-Letaba model. This node also connects the entire upper catchment with the lower catchment (B83- tertiary catchment).

Seven EWR channels were added into the basic WRYM model at their respective locations. The hydrology in the system was therefore split in accordance with the location of the EWR sites.

A portion of subcatchment B14, in quaternary catchment B81B, contributes flow to EWR Site1. 82.8% of the flow generated in this subcatchment flows into EWR Site1. Thus the hydrology was adjusted accordingly.

At each EWR point three channels were added into the WRYM configuration. The first channel to draw water required for environmental flow, the second channel to directly transfer excess water into the system, and the third to return the water drawn by the EWR channel back into the system (See Figure 4.1)

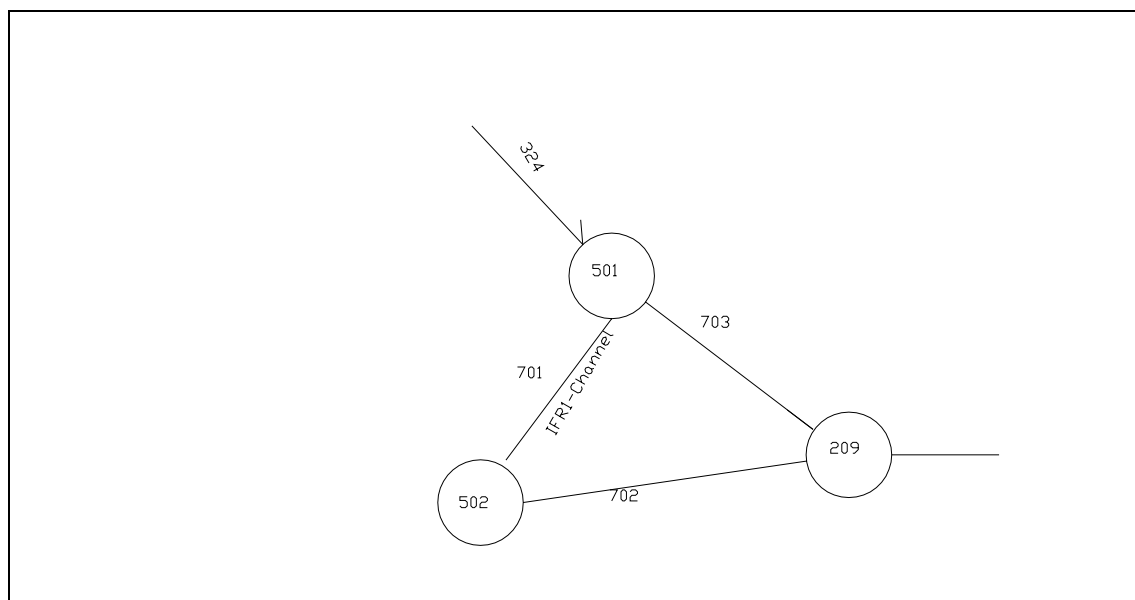

Figure 4.1: EWR channel connection in the WRYM model set up (Site1)

The Middle and Klein Letaba catchment were configured according to system setup of the subcatchment established by the previous study. This subsystem consists of two major dams, namely Middle Letaba Dam and Nsami Dam. These two dams are sources of supply to Majosi, Magoro, Bangu and Giyani, as well as irrigation farms around. The previous system setup for this sub-catchment distributed the EWR into each quaternary catchment in the tertiary catchment. However, for this project, because the EWR site was established and its requirements determined, there was no need for distributing the demand into quaternary catchments. Thus, similar to other EWR sites in the system, one EWR channel was used to simulate the EWR in this subsystem.

A configuration diagram can be found in Appendix B.

4.3 System Demand

The system demands were obtained from two sources. The Groot-Letaba demand was established during the pre-feasibility study ⁶. During the feasibility study ² projected, demands were generated up to 2020. The feasibility study speculated that there will not be major increases in irrigation demands. The projected increased demands were therefore generated for domestic use only.

Two sets of demand data were obtained for the Middle and Klein Letaba subsystem. The first set of data were used to simulate the present day contribution of the entire Letaba system to the Olifants river system. The second data set was obtained from a situation assessment study conducted in 2003 ³. The second data set was used in this study because of its conservative values and because it was considered to be a more reliable data set.

4.3.1 Domestic and industrial Demand

A summary of domestic demands and the representative channels used to simulate supply in WRYM model setup is shown in Table 4.2. The system analysis was undertaken using the 1995 demands ^{2 and 3}.

Table 4.2: Domestic demand summary

Demand Centre	WRYM Channel No.	Sources	Demand(1995) (x 10 ⁶ m ³ /a)
Plokowane	303	Dap Naude Dam	5.62
Plokowane	312	Ebenezer Dam	13.47
Duiwelskloof, Politsi & Gakgapane	332	Magoebaskloof Dam	1.52
Sapekoe	329	Magoebaskloof Dam	0.3
Letsitele Users, Ritavi2, Naphuno1, Letaba Citrus Processors	358	Tzaneen Dam	6.06
Tzaneen	348	Tzaneen Dam	3.95
Ritavi 1 and Consolidated Murchinson mines	434	Tzaneen Dam	3.34
Naphuno 1	391	Thabina Dam	2.02
Bolodedu	520	Modjaji 3 Dam	2.24
Giyani	637	Nsami Dam	6.72
Middle Letaba	622	Middle Letaba Dam	13.08
Total			58.32

4.3.2 Irrigation Demands

Irrigation demands were simulated as min-max channels or specific demand channels in the WRYM model. Most of the irrigation activities in the Letaba catchment are undertaken in an area downstream of Ebenezer dam up to Kruger National Park (KNP). Ebenezer, Tzaneen, Thabina, Middle Letaba and Nsami dams are the major water sources for irrigation. There is almost no diffuse irrigation in the catchment.

The major irrigation demands, as estimated during the Groot Letaba Water Resource Development Feasibility Study² in 1995, are depicted in Table 4.3.

Table 4.3: Irrigation Demand Summary

Demand Centre	Quaternary	WRYM Channel No.	Demand (x 10 ⁶ m ³)
A01A	B81A	310	0.36
A01B Irrigation	B81A	308	0.09
B10 Irrigation	B81B	317	1.27
Georges Valley Irrigation	B81B	318	2.58
B12 Irrigation	B81B	321	1.67
B14 Irrigation	B81B	323	1.22
B16 Irrigation	B81B	325	0.32
Pusel Irrigation	B81B	326	5.91
Vergelegen Irrigation	B81B	320	10.78
B01 Irrigation	B81B	345	0.68
B30A Irrigation	B81B	336	1.68
B30B Irrigation	B81B	339	3.13
B20	B81B	329	0.60
B01A Irrigation	B81B	342	0.24
Compensation Irrigation	B81C	349	28.21
D28 Irrigation	B81D	506	0.38
D01 Irrigation	B81D	389	2.46
D10 Irrigation	B81D	371	2.08
D13 Irrigation	B81D	383	2.87
D16 Irrigation	B81D	508	1.36
D16B Irrigation	B81D	380	1.73
D28 Irrigation	B81D	397	1.61
E01 Irrigation	B81E	365	5.10
E20 Irrigation	B81E	500	0.16
E25 Irrigation	B81E	504	3.92
E30B Irrigation	B81E	406	1.53
E30A Irrigation	B81E	408	1.53
E35B Irrigation	B81E	410	0.84
E35A Irrigation	B81E	412	0.84
E35C Irrigation	B81E	414	1.68
E20 Irrigation	B81E	416	1.95
E23B Irrigation	B81E	419	1.13
E23A Irrigation	B81E	421	1.13
G10 Irrigation	B81G	463	0.39
H01 Irrigation	B81H	471	0.50
H10 Irrigation	B81H	468	0.17
Downstream of Nwamitwa	B81F	512	27.37
B82A Irrigation	B82A	601	4.31
B82B Irrigation	B82B	605	12.58
B82C Irrigation	B82C	609	7.36

Demand Centre	Quaternary	WRYM Channel No.	Demand (x 10 ⁶ m ³)
B82D Irrigation	B82D	613	0.25
B82E Irrigation	B82E	651	0.14
Total			144.094

4.3.3 Afforestation

Because of the limited control over water used by forestry, the WRYM model, by default, gives highest priority to forestry water requirements. Previous studies indicated the annual forestry water demand in Groot Letaba to be about 50.6 million cubic metres and in the Middle and Klein Letaba to be about 6.35 million cubic metres. Afforestation water requirements in each quaternary catchment in the study area is summarised in Table 4.4.

Table 4.4 Afforestation water demand in each quaternary

Quaternary	Water Demand (10 ⁶ m ³)
B81A	12.147
B81B	30.254
B81C	0
B81D	7.239
B81E	1.0028
B82A	0.548
B82B	1.3057
B82C	1.26
B82D	1.63
B82E	0.751
B82F	0.861
	56.9985

4.3.4 Releases to Kruger National Park

While releases to Kruger National Park should be 0.6 m³/s, at present, an annual average of 0.456 m³/s flow (14.8 million m³/annum) is released to Kruger National Park from Tzaneen Dam. This release includes domestic abstraction to Letsitele users, Ritavi2, Naphuno1, and Letaba Citrus Processors. The annual demand of these users is estimated to be 6.06 million m³ as shown in Table 4.3. Thus, the effective release to Kruger National Park is 8.74 million m³/annum (0.277 m³/s).

4.3.5 International Obligations

The entire Letaba Catchment drains into the Olifants river which flows to Mozambique. At present, the international obligation of the river system have not yet been determined.

4.3.6 Return flow and Losses in the system

A total of 12 loss channels were included in the model to simulate the return flows from irrigation and losses in river beds. The summary of these channels is shown in Table 4.5.

Table 4.5 Summary of loss and return channels in Letaba system

WRYM Channel. No	Source Node	Sink Node	Loss (% inflow)	Type
513	293	225	12	Loss
516	294	220	50	Loss
518	295	0	8	Loss
521	296	0	12	Loss
523	294	220	50	Loss
572	227	301	17.4	Loss
575	302	304		Loss
602	322	330	11.5	Return
606	324	330	7.2	Return
610	328	329	7	Return
618	342	343	8.6	Return

Furthermore, losses in the Middle and Klein Letaba, downstream of Middle Letaba and Nsami dams, were simulated with two dummy dams. These dummy dams retain water generated in the quaternary catchment B82G and B82H respectively and are exposed to evaporation.

4.3.7 Level of Confidence in Demands

The 1995 demands were used in this study for the Groot Letaba catchment. For the Middle and Klein Letaba sub-catchment, the demand data obtained from the Situation Assessment Study in 2003³ was used. No major updating has been recently carried out to verify the reliability of the available data.

There is a discrepancy in various documents, especially of the studies made in the Middle and Klein Letaba. Most of the information is based on rough estimations made in the past. For instance, during pre-feasibility study stage of the water resources development potential assessment⁶, the total irrigable area in the Middle Letaba sub-catchment, upstream of the confluence with the Klein Letaba, is estimated to be 3 600 ha, with an annual water demand of 15 million cubic metres coming from surface water and the remaining 15 million cubic metres from ground water. The pre-feasibility study report⁶ indicated that the total water allocation from Middle Letaba dam is 28 million cubic metres per annum with the average release of 13 million cubic metres per annum for domestic water usage. A study, undertaken to develop operating rules for the Middle Letaba and Hudson Ntsanwisi Dams in 1994⁷, on the other hand, estimated the irrigation allocation from these dams to be 23.59 and 2.581 million cubic meters respectively. The report also indicated that the theoretical domestic demand from these two dams was 2.85 and 3.83 million cubic metres, respectively. The actual water supply from Nsami treatment plant is indicated to be almost equal to the full capacity of the plant, which is 10.72 million m³/annum. DWAF (2003)³ indicated the total allocation to be only 21.8 million cubic metres, of which 10.5 Million cubic metres is released to Nsami dam. This report further indicated that the firm yield of the dam is about 22 million cubic metres.

But there is no clear indication in the report with regard to the proportion of the irrigation and domestic allocation in the sub-catchment. In order to improve the level of confidence in the demand data, further refining and verification of the available information would be required, especially in Middle and Klein Letaba catchment.

4.4 Operation of Dams and Weirs

4.4.1 Dap Naude Dam

Dap Naude dam is the main source of water supply to Polokwane municipality. A total flow of 28 l/s is released downstream constantly.

4.4.2 Ebenezer Dam

Ebenezer dam is operated by DWAF. The main purpose of the dam is to supply water to Polokwane and Tzaneen municipality. Downstream compensation releases from this dam are represented by a minimum flow channel in the WRYM model. Monthly compensation releases, in terms of monthly average flow, are shown in Table 4.6. The dam has a release capacity of 12.4 m³/s.

Table 4.6 Monthly compensation releases (m³/s)

Oct	Nov	Dec	Jan	Feb	Mar	Apr	May	Jun	Jul	Aug	Sep
0.403	0.417	0.121	0.121	0.133	0.121	0.208	0.202	0.208	0.202	0.403	0.417

In consideration of the proposed future development, supply to Tzaneen municipality is set to be met from Tzaneen Dam rather than from Ebenezer Dam in the system setup.

4.4.3 Magoebaskloof Dam

Magoebaskloof Dam is a source of water supply to Politsi, Duiwelskloof and Ga-Kgapane towns and the surrounding irrigation farms. This dam is operated to supply domestic users at all times, but to cut irrigation supply when its water level drops below a certain level. The dam has a release capacity of 5.4 m³/s.

4.4.4 Tzaneen Dam

Tzaneen dam is the largest dam on the Groot Letaba river. Its main purpose is to provide water downstream. Tzaneen Municipality has an allocation out of the dam. This allocation has been simulated as a specific demand channel in the WRYM model. The domestic and industrial demands are simulated with min-max channels (Channels 348, 358 and 434).

Irrigation from Tzaneen dam is simulated with three channels which represent three different groups of irrigators, viz.

- Group 1: Irrigators between Tzaneen Dam and confluence of the Letsitele River with the Groot Letaba River. Simulated with min-max channel (349).
- Group 2: Irrigators downstream of the above mentioned confluence up to the Proposed Nwamitwa dam site. Simulated with min-max channel (365).
- Group 3: Irrigators downstream of the proposed Nwamitwa dam site. Simulated with a flow constraint channel (512).

All domestic demand has been allocated the next highest priority to EWR releases from Tzaneen Dam. Environmental releases currently made to KNP were excluded from the present day flows in order to independently assess the EWR at each site and to optimise the system. Once the environmental management classes have been determined and the critical EWR has been established, it is a simple matter to check if the KNP releases are being automatically met or whether supplementary releases need to be made. The dam has the capacity to release 18.5 m³/s.

4.4.5 Middle Letaba Dam

The Middle Letaba dam supplies domestic and irrigation water to towns and farms in its surrounding areas. Water is transferred to Nsami dam, which acts as a balancing dam to supply water to Giyani. No downstream compensation release is simulated from the Middle Letaba Dam. No restriction is imposed on supply from this dam, which has a release capability of 5.0 m³/s.

4.4.6 Nsami Dam

Nsami dam supplies water to Giyani. The penalty structure in WRYM for this dam is set in such a way that water is abstracted from the dam before it receives additional water from Middle Letaba dam. This dam is able to release 2.1 m³/s.

Table 4.7: Summary of major reservoir parameters used in system analysis

Reservoir Name	Node No. in WRYM	Full Supply Level (m)	Dead Storage Level (m)	Bottom Level (m)
Dap Naude	202	1548.30	1527.93	1527.00
Ebenezer	205	1352.55	1318.06	1308.00
Hans Merenskn	213	798.28	789.14	789.00
Magoebaskloof	211	838.92	811.40	808.70
Thabina	242	42.00	1.00	1.00
Tzaneen	218	723.90	694.56	689.00
Modjiadjj3	299	611.00	597.00	590.00
Middle Letba	331	534.00	515.00	501.00
Nsami	336	445.00	436.55	425.00

4.4.7 Operation of weirs in the system

Weirs in the Letaba catchment were constructed to control water distribution as well as to divert water to irrigation farms. Their main significance, in the system analysis, is in limiting the high flows required by the riparian ecology.

Between Ebenezer and Tzaneen Dam there are two small weirs, George's Valley and Pusela, which divert water released from Ebenezer dam to irrigation farms.

Downstream of Tzaneen Dam, for about 120 kilometres, there are five manually operated weirs which are used to distribute water to irrigation farms and to regulate flow to KNP. A drop in water level in each weir is compensated from an upstream weir and subsequently from Tzaneen Dam. The volume and surface area parameters of each weir were modelled in the WRYM model in order to simulate evaporation losses.

5. ECOLOGICAL WATER REQUIREMENTS

5.1 General Background

The ecological water requirements at each EWR site were generated using the Spatism model. The model generates a monthly time series of flow data which models the monthly distribution characteristics that have been selected in order to meet certain ecological criteria. These distribution characteristics are input as discharge rates that represent the drought low flow, maintenance low flow and high flow requirements respectively, for each month of the year. Selection of the discharge rates for low and drought flows are based on a manipulation of the default Desktop Reserve values generated by the model in order to “fit” the stressor-response duration curves determined by the fish and invertebrate specialists. This curve fitting is initially carried out with the high flows set to zero, since introduction of the high flows distorts the wet season frequency distribution. Only once the low flow distribution time series has been generated, to achieve a best fit of requirements, are the maintenance high flows, determined largely by the geomorphologist and riparian vegetation specialists, introduced into the time series and the assurance rules generated.

5.2 Desktop Reserve Parameter Selection

Default regionalised and quaternary based parameters are initially setup in the Desktop Reserve Model in order to generate Desktop EWRs.

These parameters are:

- Desktop Single Parameters which are regionalised
- Desktop Monthly Distribution Parameters which are quaternary catchment based
- Desktop Ecological Reserve Category Parameters which are quaternary catchment based

During the curve fitting procedure, as described above, it may be necessary to alter some of the monthly distribution parameters in order to achieve a best fit. In most cases, a good fit can be achieved merely through manipulation of the maintenance low and drought flow values.

For the selected EWR sites, some manipulation of the monthly distribution parameters was required. All of the parameters used for this project in the Desktop Reserve Model are included in Appendix C.

5.3 Flow-Stressor Response Modelling

The Flow-Stressor Response model is suited to the evaluation of low flows. The stress response of fish and invertebrates to various flow rates during the dry and wet months of the year are rated from zero to 10, where zero implies no stress and 10 implies maximum stress. These stress levels were determined, at each EWR site, by the fish and invertebrate specialists, taking into account the hydraulics (depth and velocity) relating to different flows. These values were entered into the Stress/Flow and Risk Indicator module within Spatsim and used to generate an integrated flow stressor-response index for each EWR site. From this relationship, and using the

modified time series generated by the Desktop Reserve model, monthly frequency distribution curves of stress response were generated.

The stress response curve and low-flow and drought frequency distribution points were generated at a workshop by the specialists and used as a reference to generate the low flow time series EWRs. The flow stressor-response indices that were used are shown in Figure 5.1 below. The integrated line represents the maximum stress envelope.

EWR Site1

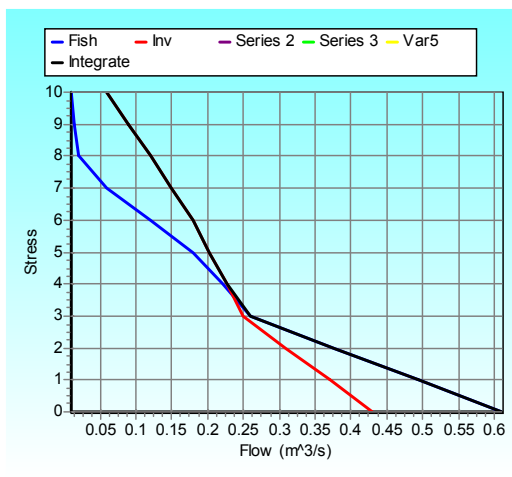

EWR Site2

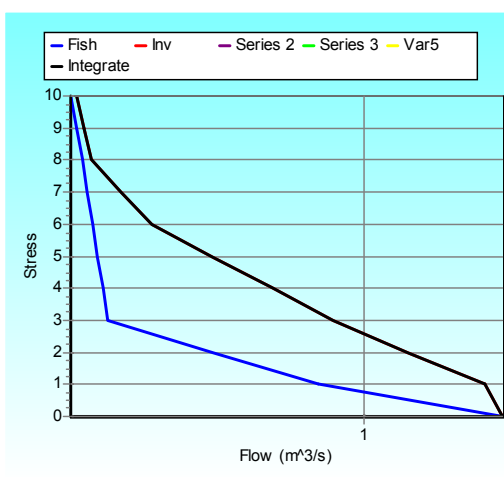

EWR Site3

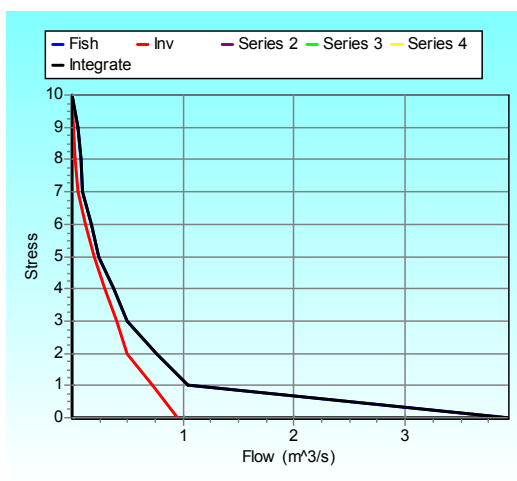

EWR Site4

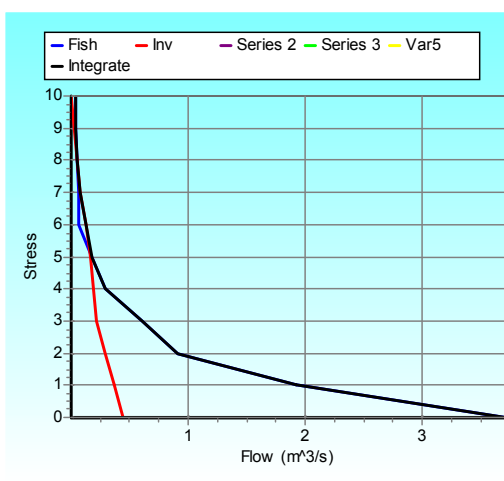

EWR Site5

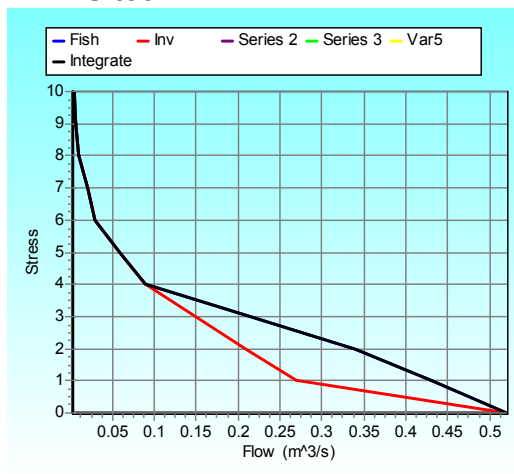

EWR Site6

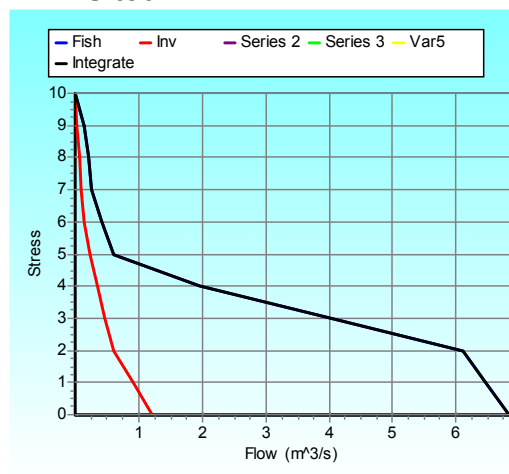

EWR Site7

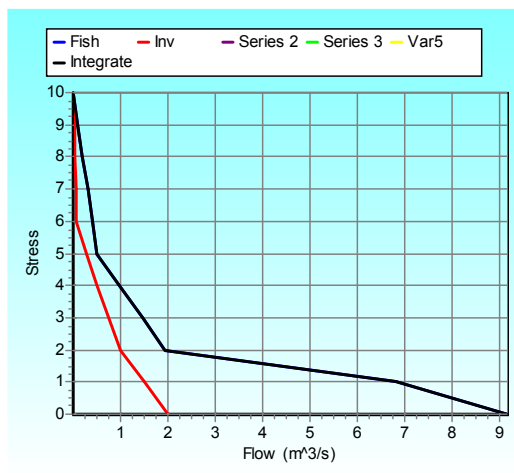
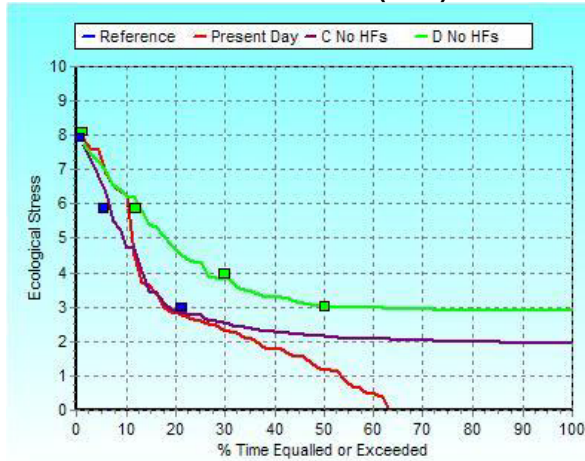

Figure 5.1: Flow Stressor Response Indices for EWR Sites 1 to 7

The fitted stress distribution curves for each site, for the selected ecological categories, are shown in Figures 5.8 to 5.21 below. The rectangular points indicate the integrated low flow requirements as set by the specialists. The Reference line represent the natural condition under virgin flow and the Present Day line represents the current situation (without KNP releases). The ecological category lines represent the distribution of the Desktop Reserve Model low flow time series, adjusted to fit the set requirements.

EWR Site1 Wet Month (Feb)



EWR Site1 Dry Month (Sept)

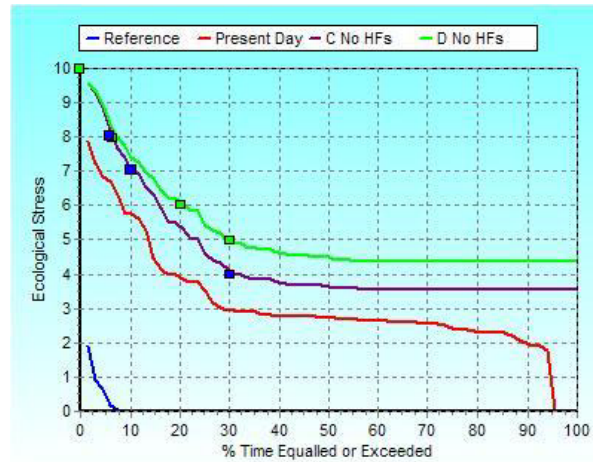

EWR Site2 Wet Month (Feb)

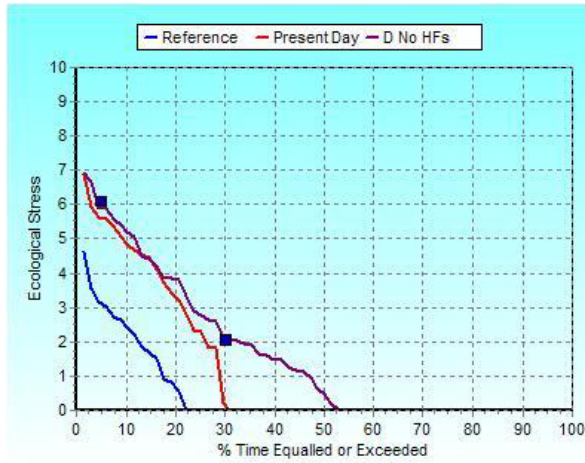

EWR Site2 Dry Month (Sept)

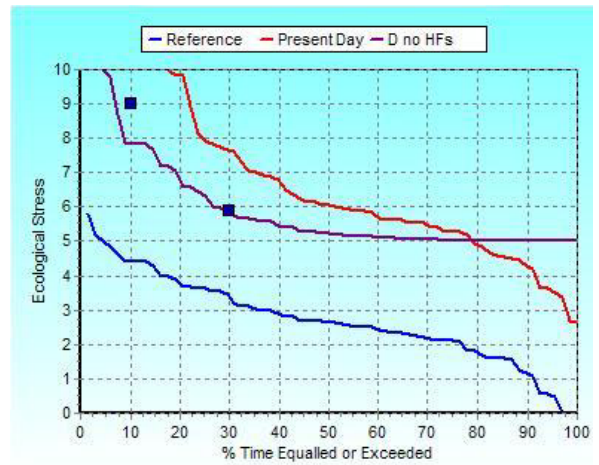

EWR Site3 Wet Month (Feb)

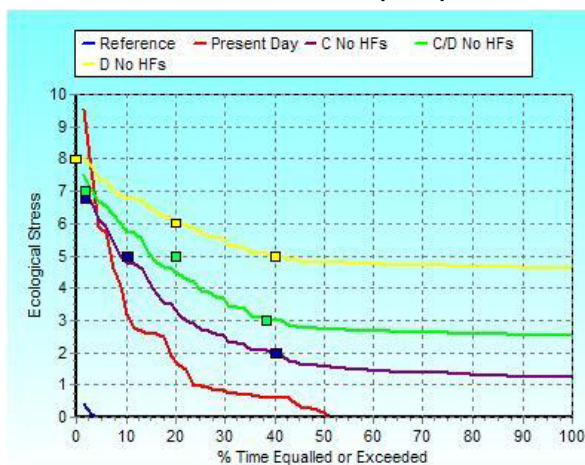

EWR Site3 Dry Month (Sept)

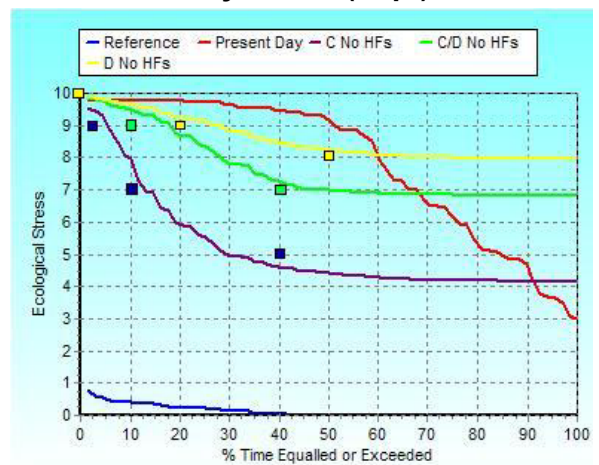

EWR Site4 Wet Month (Feb)

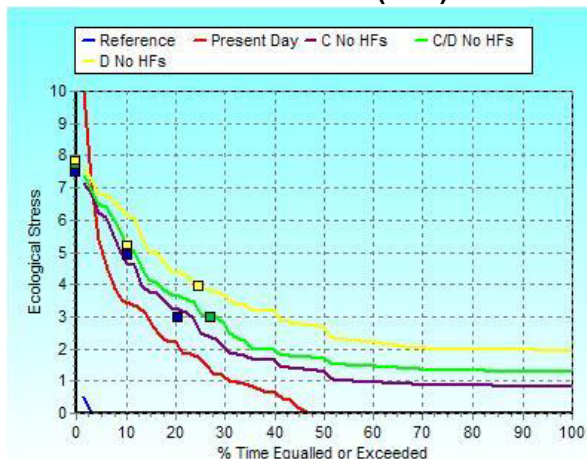

EWR Site4 Dry Month (Sept)

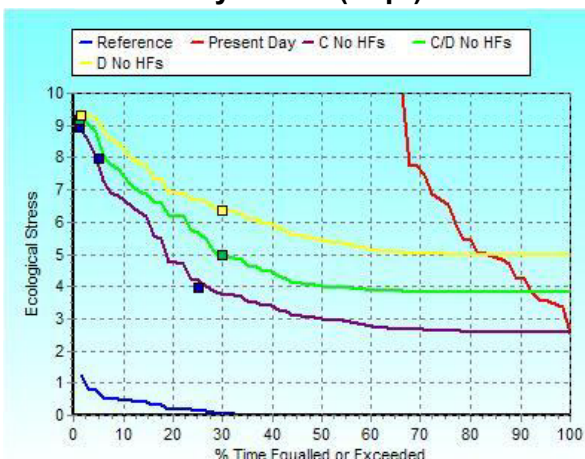

EWR Site5 Wet Month (Feb)

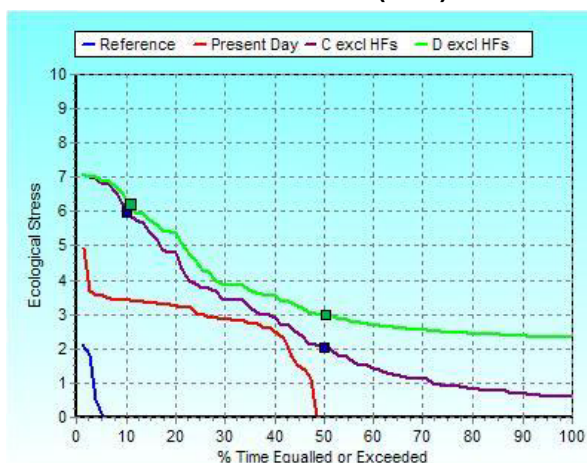

EWR Site5 Dry Month (Sept)

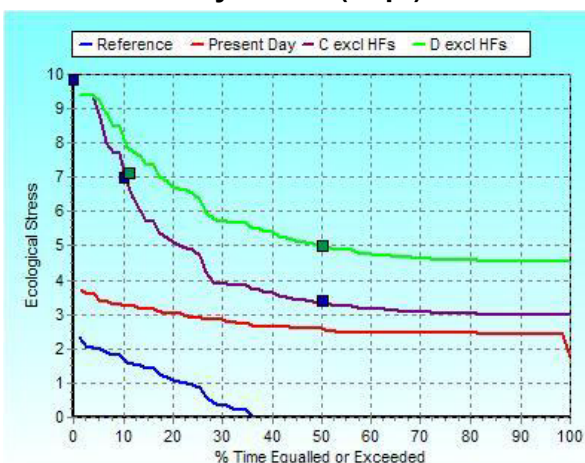

EWR Site6 Wet Month (Feb)

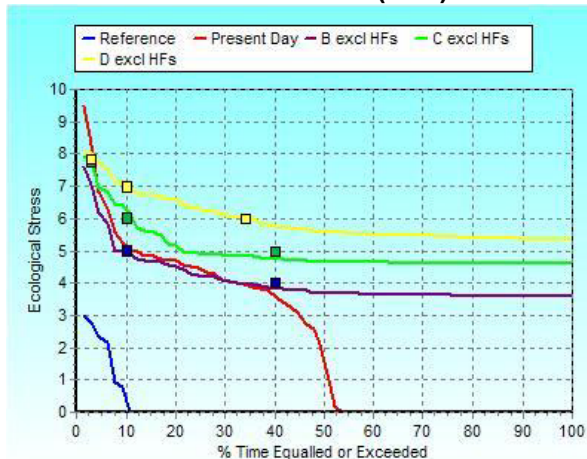

EWR Site6 Dry Month (Jul)

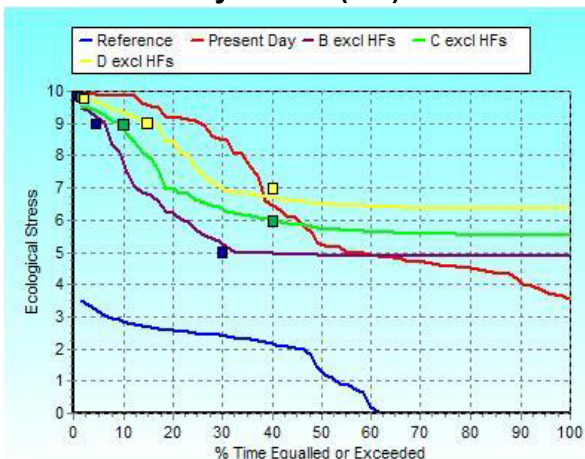

EWR Site7 Wet Month (Feb)

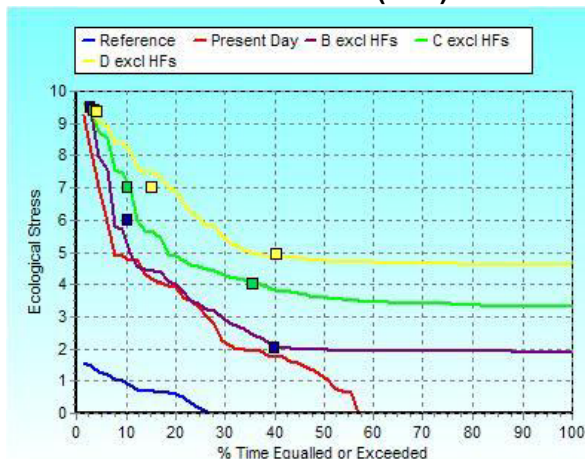

EWR Site7 Dry Month (Jul)

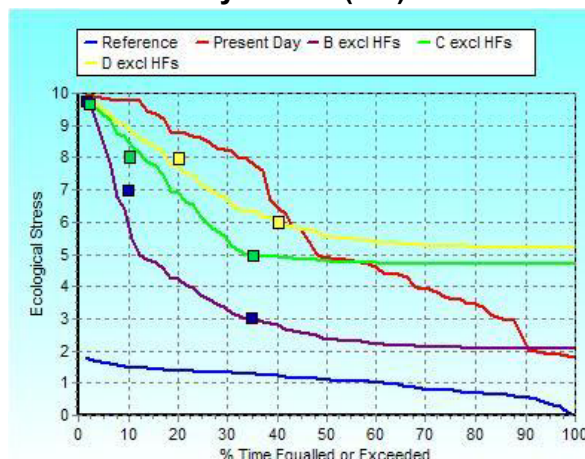

Figure 5.2: Fitted Stress Distribution Curves for the Selected Ecological Categories for Wet and Dry Months for EWR Sites 1 to 7.

5.4 Flood Requirements

The Flow-Stressor Response model is not suited to the evaluation of high flows. High flows need to be set based on ecological trigger requirements for fish and invertebrates as well as for maintaining river shape and riparian vegetation. Therefore, based on the hydrology and hydraulics of each EWR site, various flood class ranges were recommended by the specialists during the first workshop.

5.4.1 High Flow Requirements at the EWR sites

The high flows required at each of the sites are shown in Tables 5.1 to 5.14.

Table 5.1: Maintenance high flow requirements for EWR Site1

Component	I	II	III	IV	V
Fish (m ³ /s)	1.2-1.8;1.5-2.5;2-2.5		4.5-7		
Invertebrates (m ³ /s)		2-4			
Vegetation (m ³ /s)			4.5-10.5	20-27	43-94
Geomorphology (Daily Average)		5	10	20	
Integrated	1.2-2.5	2-5	4.5-10.5	20-28	43-94(1:5)
Daily Average	2	3.5	8	20 (C) 15 (D)	
Duration (Days)	2	3 (C) 2 (D)	4	6	

Table 5.2: Flood Class and number of events summary at EWR1

Flood Classes	Flood Range	Number of Events: EC C						Number of Events: EC D					
		Invert	Fish	Veg	Geom	Final	Integrated	Invert	Fish	Veg	Geom	Final	Integrated
Class I	1.2-2.5		12 (O-Ma)			12 (N-Ma)	2 (N & Ma)		6			6 N-Mar	1 (F)
Class II	2-5 (N, Ap)			6	6		6 (N-ma)	2 (N,Ap)			4	4	4(Ja, M, A, N)
Class III	4.5-10.5		1 (N)	1 (A)	2	2	2 (D,A)				1	1	1 (D)
Class IV	20-28			1	1:2	1	1(F)			1:2	1:2	1:2	15(F)

Table 5.3: Flood requirement of riparian ecology components at EWR2

Component	I	II	III
Fish (m ³ /s)	2.5-3.5		
Invertebrates (m ³ /s)	2-3	3.5-6	
Vegetation (m ³ /s)			
Geomorphology (m ³ /s Daily Average)	2.7		15
Integrated	2.5-4	3.5-6	15
Daily Average (m ³ /s)	3.5	4.5	15
Duration (Days)	2	2	3

Table 5.4: Flood class and number of events summary at EWR2

Flood Classes	Flood Range	Number of Events: EC D					
		Invert	Fish	Veg	Geom	Final	Integrated
Class I	3		8 (O-Ma)		15	15	10 (1N,2 (D-M),1A)
Class II	3.5 -6		1			1	1(D)
Class III	12				2	2	2(F,D)

Table 5.5: Flood requirement of riparian ecology components at EWR3

Component	I	II	III	IV	V
Fish (m ³ /s)	6-10	10-15	4.5-7		
Invertebrates (m ³ /s)		10-15			
Vegetation (m ³ /s)	4-6	12-18	50-90	150-220	330-480
Geomorphology (m ³ /s Daily Average)		15	70-100	150	
Integrated	6-10	12-18	50-90	150-220	
Daily Average (m ³ /s)	7	14	70	160	
Duration (Days)	2	3	4	6	

Table 5.6: Flood class and number of events summary at EWR3

Flood Classes	Flood Range	Number of Events: EC C						Number of Events: EC C-D						Number of Events: EC D					
		Invert	Fish	Veg	Geom	Final	Integrated	Invert	Fish	Veg	Geom	Final	Integrated	Invert	Fish	Veg	Geom	Final	Integrated
Class I	6-10		2	4		4	4(N,A,F)		6	6		6	6 (N-A)		8	8		8	8(O-A) 2(D)
Class II	12-18	2	1	2		2	2 (D,M)	2	1	3		3	3 (D, J,M)	3	1	3		3	3 (D,J,M)
Class III	50-90			1		1	1(F)		1	1		1	1(F)						1(F)
Class IV	150-220			1:3	1:3	1:3	1:3*		1:2	1:2		1:2	1:2 (M)**			1:2	1:2	1:2	1:2 (M)

Table 5.7: Flood requirement of riparian ecology components at EWR4

Component	I	II	III	IV	V
Fish (m ³ /s)	4-8	8-22			
Invertebrates (m ³ /s)		10-15			
Vegetation (m ³ /s)		6-22	60-180	250-420	650-1000
Geomorphology (m ³ /s Daily Average)	6		60	130	
Integrated	4-8	10-12	60-180	250-420	650-100 (1:10)
Daily Average (m ³ /s)	6	15	60	150	
Duration (Days)	3	4	6	6	

Table 5.8: Flood class and number of events summary at EWR4

Flood Classes	Flood Range	Number of Events: EC C						Number of Events: EC C-D						Number of Events: EC D					
		Invert	Fish	Veg	Geom	Final	Integ	Invert	Fish	Veg	Geom	Final	Integ	Invert	Fish	Veg	Geom	Final	Integ
Class I	4-8		7			7	4 (J,A,N D)		5			5	5(J-A N,D)		3			3	3 (J,F,D)
Class II	10-22	3		6		6	6(J-A, N,D)	2		4		4	4(J,A, N,D)	2		4		4	4 (J,A,N,D)
Class III	60-180			2		2	2 (D,J)			1	1	1	1 (m)			1	1		1 (M)
Class IV				2	1:2	2	F			1	1:2	1	F			1	1:3		1 (F)

Table 5.9: Flood requirement of riparian ecology components at EWR5

Component	I	II	III	IV	V
Fish (m ³ /s)	8-12	16-25			
Invertebrates (m ³ /s)	2-4	10-15			
Vegetation (m ³ /s)	1.7-27		60-126	175-480	500
Geomorphology (m ³ /s Daily Average)		14	70		500
Integrated	8-12	14-25	60-126	175-480	
Daily Average (m ³ /s)	8	12	60	150	
Duration (Days)	2	3	4	5	

Table 5.10: Flood class and number of events summary at EWR5

Flood Classes	Flood Range	Number of Events: EC C						Number of Events: EC D					
		Invert	Fish	Veg	Geom	Final	Integrated	Invert	Fish	Veg	Geom	Final	Integrated
Class I	8-12	3 (O,F A)	1 (D)	6 (N-A)		6	6(N-A)	2 (O,F)	3 (N, D,A)	4 (N,J F,M)		4	4(N,D, J,A)
Class II	14-29		2(N,A)	3	2	3	3 (N,F,A)			2	1:2	2	2 (D ,F)
Class III	60-126			1(D,M)	1:2	1	1 (M)			1:2 (M)	1:3	1:2	1:2 (40 in March)
Class IV	175-480			1:10		1:10	1:10			1:10		1:10	1:10

Table 5.11 Flood requirement of riparian ecology components at EWR6

Component	I	II	III	IV	V
Fish (m ³ /s)	5-8	7-15			
Invertebrates (m ³ /s)		10-15			
Vegetation (m ³ /s)		10-27	80-150	300-500	2000
Geomorphology (m ³ /s Daily Average)		20	80	360 (instant peak)	2000
Integrated	5-8	10-27	80-150	300	
Daily Average (m ³ /s)	6	15	120		
Duration (Days)	3	4	6	8	

Table 5.12 Flood class and number of events summary at EWR6

Flood Classes	Flood Range	Number of Events: EC B						Number of Events: EC C						Number of Events: EC D						
		Invert	Fish	Veg	Geom	Final	Integ	Invert	Fish	Veg	Geom	Final	Integ	Invert	Fish	Veg	Geom	Final	Integ	
Class I	5-8		2			0	2		5			2	5(D-A)		8					2
Class II	10-27	2	2	4	2	4	4	2	2	5	3	5	5 (O,N,D,J,A)	3	2	6	4			6
Class III	80-150			1	1	1	1			2	1	1	2(J,M)			3	1			1
Class IV	300			1:2	1:2	1:2	1:5			1	1	1:5	1F			1	1			1:5

Table 5.13 Flood requirement of riparian ecology components at EWR7

Component	I	II	III	IV	V
Fish (m ³ /s)	5-8	7-15			
Invertebrates (m ³ /s)		10-15			
Vegetation (m ³ /s)		10-30	85-160	300-550	2000-3800
Geomorphology (m ³ /s Daily Average)		22	90	220	2500
Integrated	5-8	10-30	80-160	300-550	2000-3800
Daily Average (m ³ /s)	6	15	120		
Duration (Days)	3	4	6	8	

Table 5.14 Flood class and number of events summary at EWR7

Flood Classes	Flood Range	Number of Events: EC B						Number of Events: EC C						Number of Events: EC D					
		Invert	Fish	Veg	Geom	Final	Integ	Invert	Fish	Veg	Geom	Final	Integ	Invert	Fish	Veg	Geom	Final	Integ
Class I	5-8		2			0	2		7			2	5(3xD J-A)		8				2
Class II	7-15	2	2	3	2	4	4	2	2	5	3	5	5 (O,N,D,J,A)	3	2	6	4		6
Class III	80-160			1	1	1	1			2*	1	1	2 (F)			3	1		1
Class IV	300-550			1:2	1:2	1:2	1:5			1*	1	1:5	1F			1	1		1:5

6. OPERATIONAL SCENARIO MODELLING

As described above, the system model setup from previous studies ² was adopted with minor modifications at nodes where EWR requirements needed to be evaluated. Based on this system setup, various scenarios, as proposed by the ecological specialists, were tested in order to investigate an optimum scenario for meeting the ecological requirements at the various sites, while minimising the impact on the Letaba water supply system.

6.1 Scenario Description

The requirements for various ecological categories were considered during the analysis. Generally, these were for the Present Ecological State (PES) and then for a condition above and below PES. The ecological categories considered during this analysis, at various the EWR sites, are shown on Table 6.1.

Table 6.1: EWR sites and ecological categories

EWR Site	Ecological Category	Status
1	C	PES
	D	Below PES
2	D	PES
3	C	Above PES
	C/D	PES
	D	Below PES
4	C	Above PES
	C/D	PES
	D	Below PES
5	C	PES
	D	Below PES
6	B	Above PES
	C	PES
	D	Below PES
7	B	Above PES
	C	PES
	D	Below PES

During the course of the analysis, certain adjustments were made to the ecological high flow requirements, in consideration of the release capacity of upstream controlling dams together with the first three scenarios as described hereunder.

6.1.1 Scenario 1

This scenario comprises of the present ecological state requirement at each site. The ecological categories and the mean annual requirement at each site are shown in Table 6.2.

Table 6.2: Summary of Mean Annual Requirement for the PES Ecological Category at each EWR site under Scenario 1

EWR Site	Ecological Category	Mean annual Requirement (million m³)
1	C	19.75
2	D	23.473
3	C-D	51.569
4	C-D	87.511
5	C	23.06
6	C	58.68
7	C	64.785
Total		328.828

6.1.2 Scenario 2

Scenario 2 comprises the condition Below PES ecological requirement at each site. The ecological categories and the mean annual requirement at each site is shown in Table 6.3.

Table 6.3: Summary of Mean Annual Requirement for the Below PES Ecological Category at each EWR site under Scenario 2

EWR Site	Ecological Category	Mean annual Requirement (million m³)
1	D	14.267
2	D	23.473
3	D	20.186
4	D	80.451
5	D	16.081
6	D	50.09
7	D	54.117
Total		258.647

6.1.3 Scenario 3

Scenario 3 comprises the Above PES ecological requirement at each site. The ecological categories and the mean annual requirement at each site is shown in Table 6.4.

Table 6.4: Summary of Mean Annual Requirement for the Above PES Ecological Category at each EWR site under Scenario 3

EWR Site	Ecological Category	Mean annual Requirement (million m ³)
1	C	19.75
2	D	23.473
3	C	61.363
4	C	131.82
5	C	23.06
6	B	72.609
7	B	93.362
Total		425.437

6.1.4 Scenario 4

Using Scenario 1 as a baseline case, the following modifications were made to establish Scenario 4:

- At EWR1
 - flows greater than 8 m³/s were removed. That is, while generating the ecological requirement time series, all high flows greater than 8 m³/s were removed from the rule table.
- At EWR2
 - all high flows were removed
 - dry period low flow was made to be equal to the present day flows
 - wet season low flows were maintained as for Scenario 1
- EWR3 and EWR4
 - No requirements were allocated to these site in order to check if the demands at these sites could be met as a result of supplying the requirements at EWR 6 and 7
- EWR5
 - Low flow in June and July was decreased to be equal to present day
 - High flow in November was moved to January
 - High flow in April was moved to March
- EWR6 and 7
 - High flows in October were moved to February

Table 6.5: Summary of Mean Annual Requirement at each EWR site for various Ecological Categories under Scenario 4

EWR Site	Ecological Category	Mean annual Requirement (million m ³)
1	C	11.635
2	D	23.073
3	C	0
4	C	0
5	C	25.528
6	C	59.114
7	C	65.222
Total		184.572

6.1.5 Scenario 5

Using Scenario 4 as a baseline, if EWR3 and 4 PES requirements were not met under Scenario 4, then the following modification were proposed to establish Scenario 5:

- Set EWR3 requirements for PES
- For EWR4 requirements, decrease August, September and October low flows to present day flows. Move the November flood to December or any other high month, so that there is no conflict.

6.1.6 Scenario 6

Using Scenario 2 as a baseline, the following modifications were made to create this scenario:

- For EWR1 all high flows greater than 8 m³/s have been removed
- For EWR2 the same changes as for Scenario 4
- For EWR 6 and 7 the high flows in October were moved to February

Table 6.6: Summary of Mean Annual Requirement at each EWR site for various Ecological Categories under Scenario 6

EWR Site	Ecological Category	Mean annual Requirement (million m ³)
1	D	8.475
2	D	23.073
3	D	0
4	D	0
5	D	16.081
6	D	49.915
7	D	56.291
Total		153.835

6.1.7 Scenario 7

Using Scenario 2 as a baseline, a similar modification to Scenario 5 was proposed.

- Set EWR3 requirements for Below PES
- For EWR4 below PES requirements, decrease August, September and October low flows to present day flows. Move the November flood to December or any other high month, so that there is no conflict.

6.1.8 Scenario 8

Scenario 1 was used as a baseline with all modifications as made in Scenario 4 and high flow requirements removed at EWR6 and 7

Table 6.7: Summary of Mean Annual Requirement at each EWR site for various Ecological Categories under Scenario 8

EWR Site	Ecological Category	Mean annual Requirement (million m ³)
1	C	11.635
2	D	23.073
3	C	0
4	C	0
5	C	25.528
6	C-low flow only	14.549
7	C-low flow only	20.623
Total		95.408

6.1.9 Scenario 9

Scenario 2 was used as a baseline with all modifications made in Scenario 6 and high flow requirements removed at EWR6 and 7.

Table 6.8: Summary of Mean Annual Requirement at each EWR site for various Ecological Categories under Scenario 9

EWR Site	Ecological Category	Mean annual Requirement (million m ³)
1	D	8.475
2	D	23.073
3	D	0
4	D	0
5	D	16.081
6	D	8.542
7	D	12.538
Total		68.709

6.1.10 Scenario 10

Scenario 10 was established with Scenario 1 as a base line, with all the modifications made under Scenario 4 and with further modifications as follows:

- EWR1 as scenario 4
- EWR2 as scenario 4
- EWR3 with flows > 18m³/s removed
- EWR4 only low flow
- EWR5 with flows > 5 m³/s removed
- EWR6 and 7 C category Low flow only

This scenario takes into consideration the outlet capacity of controlling dams upstream of each EWR site. At EWR3 the ecological flow requirement was limited to maximum of 18 m³/s because this is the outlet capacity of Tzaneen Dam. Similarly the outlet capacity of Middle Letaba made the requirement at downstream EWR sites to be limited to 5m³/s flow under this scenario.

Table 6.9: Summary of Mean Annual Requirement at each EWR site for various Ecological Categories under Scenario 10

EWR Site	Ecological Category	Mean annual Requirement (million m ³)
1	C	19.75
2	D	23.073
3	C	18.252
4	C	21.870
5	C	9.676
6	C	14.549
7	C	20.623
Total		127.793

6.1.11 Scenario 11

Scenario 11 is similar to scenario 10 but Scenario 2 as a base line. The following modification were made to establish this scenario:

- EWR1 as scenario 6
- EWR2 as scenario 6
- EWR3 D category with flows > 18m³/s removed
- EWR4 only low flow for D
- EWR5 as scenario 6
- EWR6 and 7D category Low flow only

Table 6.10: Summary of Mean Annual Requirement at each EWR site for various Ecological Categories under Scenario 11

EWR Site	Ecological Category	Mean annual Requirement (million m ³)
1	D	8.475
2	D	23.073
3	D	13.281
4	D	15.912
5	D	6.133
6	D	8.542
7	D	12.538
Total		87.954

6.1.12 Scenario 12

- Similar to Scenario 10 without putting any EWR demand at EWR 6 and 7

Table 6.11: Summary of Mean Annual Requirement at each EWR site for various Ecological Categories under Scenario 12

EWR Site	Ecological Category	Mean annual Requirement (million m ³)
1	C	19.75
2	D	23.073
3	C	18.252
4	C	21.870
5	C	9.676
6	B	0
7	B	0
Total		92.621

6.1.13 Scenario 13

Scenario 10 was used as a baseline with the following modification:

- EWR3 D category used with dry period flow (October, September, August, July and June) removed

Table 6.12: Summary of Mean Annual Requirement at each EWR site for various Ecological Categories under Scenario 13

EWR Site	Ecological Category	Mean annual Requirement (million m ³)
1	C	19.75
2	D	23.073
3	D	12.176
4	C-Low flow	21.870
5	C	9.676
6	C-Low flow	14.549
7	C-Low flow	20.623
Total		121.717

6.1.14 Scenario 14

Similar to scenario 13 but with D category requirements at EWR4, 6 and 7.

Table 6.13: Summary of Mean Annual Requirement at each EWR site for various Ecological Categories under Scenario 14

EWR Site	Ecological Category	Mean annual Requirement (million m ³)
1	D	8.475
2	D	23.073
3	D	12.176
4	D-Low flow	15.912
5	D	6.133
6	D-Low flow	8.542
7	D-Low Flow	12.538
Total		86.849

6.2 Impact of Scenarios on Water Supply

The impact of various scenarios on the water supply in the Letaba system was investigated based on mean annual supply in comparison to the demands including EWRs, and the mean annual supply under the condition when there is no ecological releases (NO EWR case).

6.2.1 Impact on Subsystem Upstream of Tzaneen Dam

This subsystem is where the major economic activities take place. It is also the main source of water supply to Polokwane municipality.

As shown in Table 6.14 below, the total domestic water allocation from this subsystem is 21.51 million m³ /annum. Under present conditions, without supplying the riparian ecology, the system can supply 98.15% of the allocation. This supply decreased to 82.16% under Scenario 3. Because of the huge EWR requirement under Scenario 3 (above PES), this severely affected the systems supply capacity. With optimised scenarios (supplying PES requirements as a minimum) the system indicated that it could supply 97.71% of the allocation. This is 99.6% of the domestic water that could be supplied under the present day condition.

Table 6.14 Demand and supply comparison under various scenarios upstream of Tzaneen Dam

Type Dem	Total Demand (10 ⁶ m ³ /an)	Supply under various Scenario (10 ⁶ m ³ /an)											
		Scenarios											
		NO EWR	1	2	3	4	6	8	10	11	12	13	14
Domestic	21.51	21.11	19.28	20.26	17.67	20.64	20.73	21.02	21.02	21.11	21.02	21.02	21.02
(%of supply-Dem)	100.00	98.15	89.62	94.20	82.16	95.95	96.39	97.71	97.71	98.15	97.71	97.71	97.71
Irrigation	29.94	29.38	28.31	28.37	26.54	28.59	29.00	29.03	29.03	29.19	29.10	29.10	29.10
(%of supply-Dem)	100.00	98.13	94.56	94.77	88.65	95.50	96.87	96.98	96.98	97.51	97.19	97.19	97.19

6.2.2 Impact Downstream of Tzaneen up to Confluence of Middle and Klein Letaba

The major sources of supply in this area is Tzaneen Dam. The total allocation for Tzaneen Municipality was set to be met from Tzaneen dam in the WRYM setup. As shown in Table 6.15, the domestic demand can be met under NO EWR condition. However, irrigation demands could not be met under this condition. The supply is comparable to the NO EWR condition under Scenarios 10, 11,12 13 and 14, due to the fact that most of the EWR allocation under these scenarios could be met by spills in the subsystem.

6.2.3 Letsitele and Nwanedzi Subcatchment

This subsystem is the most stressed subsystem in the entire Letaba catchment. The only domestic supply simulated in this subsystem is the supply from Thabina dam to Naphuno 1. (See Table 6.16) In each subsystem, domestic demand received highest priority next to ecological requirements. Because of the high priority allocated to domestic demand, it did not fail under all scenarios. However, the allocated irrigation demand failed to be met under all scenarios including the base scenario (present day condition without EWR requirement).

Table 6.15: Demand and supply comparison under various scenarios Downstream of Tzaneen up to the Confluence of Middle and Klein Letaba

Type of Demand	Total Demand (10 ⁶ m ³ /an)	Supply under various Scenario (10 ⁶ m ³ /an)											
		NO EWR	1	2	3	4	6	8	10	11	12	13	14
Domestic	15.59	15.59	15.34	15.43	14.36	15.53	15.56	15.53	15.59	15.59	15.59	15.59	15.59
(%of supply-Dem)	100.00	100.00	98.36	98.96	92.10	99.59	99.79	99.59	100.00	100.00	100.00	100.00	100.00
Irrigation	61.73	61.58	58.51	59.55	49.14	60.81	61.07	61.58	61.58	61.58	61.58	61.58	61.58
(%of supply-Dem)	100.00	99.76	94.78	96.47	79.60	98.51	98.92	99.76	99.76	99.76	99.76	99.75	99.75

Table 6.16: Demand and supply comparison under various scenarios Letsitele and Nwanedzi Subcatchment

Type Demand	Total Demand (10 ⁶ m ³ /an)	Supply under various Scenario (10 ⁶ m ³ /an)											
		Scenarios											
		NOEWR	1	2	3	4	6	8	10	11	12	13	14
Domestic	2.02	2.02	2.02	2.02	2.02	2.02	2.02	2.02	2.02	2.02	2.02	2.02	2.02
(%of supply-Dem)	100.00	100.00	100.00	100.00	100.00	100.00	100.00	100.00	100.00	100.00	100.00	100.00	100.00
Irrigation	27.17	22.69	20.92	22.06	20.32	21.65	21.65	21.65	21.59	21.62	21.62	21.65	21.65
(%of supply-Dem)	100.00	83.52	77.02	81.20	74.81	79.69	79.69	79.69	79.46	79.58	79.58	79.69	79.69

6.2.4 Middle and Klein Letaba subcatchment

Of all scenarios, Scenario 4 and Scenario 6, as shown in Table 6.17 below, significantly affected the system supply capacity. This is because EWR6 and EWR7 were pulling water from this subsystem due to limited contribution of the Groot Letaba subsystem.

Because of the huge domestic and irrigation demands allocated in the area, the system failed to meet the domestic and irrigation demands, even under the baseline scenario with no EWR supplied.

Table 6.17: Demand and supply comparison under various scenarios in the Middle and Klein Letaba Subcatchments

Type Dem	Total Demand (10 ⁶ m ³ /an)	Supply under various Scenario (10 ⁶ m ³ /an)											
		Scenarios											
		NO EWR	1	2	3	4	6	8	10	11	12	13	14
Domestic	20.52	18.05	15.05	13.76	12.28	11.30	12.53	13.32	17.95	17.63	17.67	17.58	17.58
(%of supply-Dem)	100.00	87.97	73.36	67.05	59.82	55.06	61.05	64.90	87.49	85.93	86.12	85.66	85.66
Irrigation	24.64	18.84	17.01	15.87	13.89	13.92	15.49	16.50	18.78	18.66	18.68	18.52	18.52
(%of supply-Dem)	100.00	76.46	69.03	64.42	56.35	56.48	62.88	66.98	76.20	75.71	75.83	75.18	75.18

7. SUMMARY

In general, as can be seen in the tables in Section 6.2, the Letaba water system is under stress. It is obvious that ecological releases will impose further additional stress into the system. The relative impact of EWR releases depends on the amount, frequency and seasonal distribution of releases. As shown in the previous section, curtailing ecological releases (Scenarios 13 and 14), during the dry period, significantly improves the water supply capacity of the system without severely compromising the ecological stability. Under these two scenarios it is possible to attain an average water supply that is comparable to the supply under the NO EWR condition.

Figures 7.1 and 7.2 indicate, as an example, the supply under various scenarios as compared with the EWR requirement under present condition using the stress response graph. Under the latter scenarios (Scenarios 13 and 14) effort had been made to fine tune the supply to closely match the ecological requirements. Getting a perfect fit on the stress response curve would be quite exhaustive, but as shown in Figures 7.1 and 7.2, a better result was obtained under these two scenarios. N.B: The stress response graphs of various scenarios for the selected EWR sites can be referred in Appendix C (electronic format).

Scenario 14 was presented as the optimised scenario (and called scenario 7 as this scenario was just optimisations of the original scenario 7) when these scenarios were presented to the ecologists as well as DWAF's management team.

The optimised scenario flow duration curves per month are indicated in Appendix B.

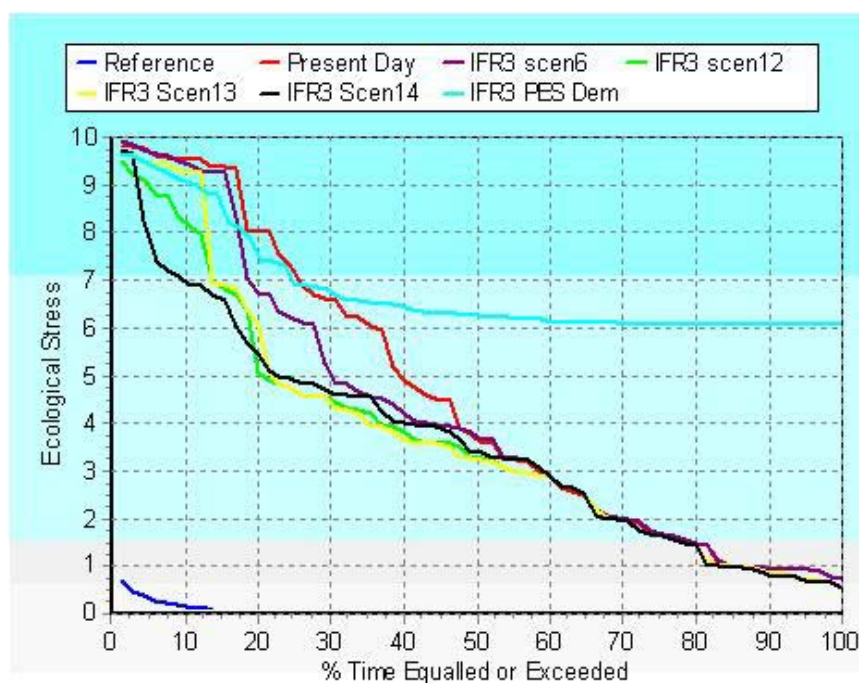

Figure 7.1: Stress Response in September at EWR3

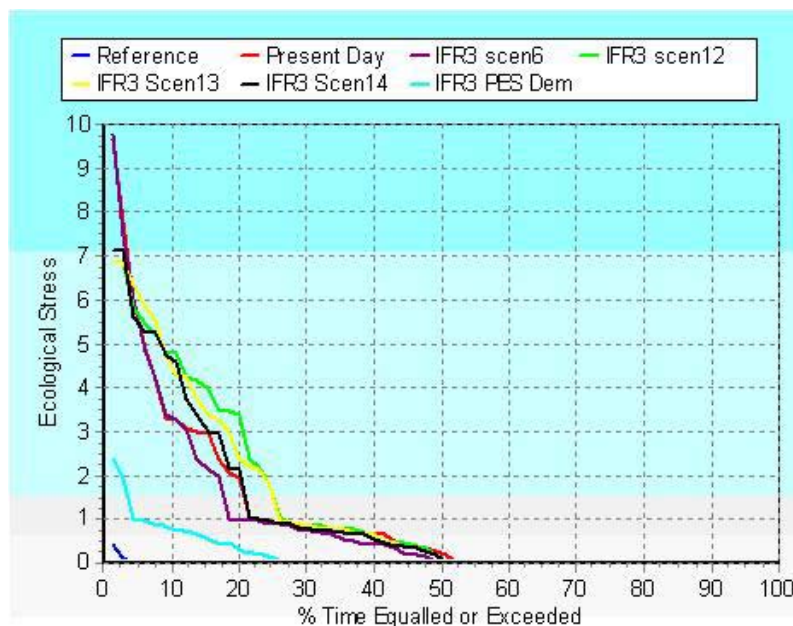

Figure 7.2: Stress Response in February at EWR3

Scenario 14 (Optimised scenario) resulted in less ecological stress in both the summer and winter months and an acceptable demand and supply to the main users in the catchment per EWR site.

Table 7.1 indicates the EWR as a percentage of MAR as well as the long term mean as a percentage of virgin MAR per EC that was modelled per site.

Table 7.1 The EWR as a percentage of MAR and the long term mean as a percentage of virgin MAR per EC at each site.

Site	Category	EWR as % of MAR				Long term mean as % of Virgin MAR	
		Total	Maint. Low	Drought	Maint. High	Total Flow	% MAR
		% MAR	% MAR	% MAR	% MAR	mcm	% MAR
1	C	24.20%	16.70%	9.10%	7.51%	19.332	26.97%
	D	15.52%	9.00%	9.10%	6.52%	17.067	23.81%
2	D	15.18%	8.25%	8.25%	6.93%	16.868	19.60%
3	C	23.73%	15.91%	8.49%	7.82%	98.055	26.90%
	C/D	19.46%	12.31%	8.49%	7.15%	80.83	22.18%
	D	15.29%	8.49%	8.49%	6.80%	90.615	24.86%
4	C	23.38%	15.30%	8.09%	8.08%	129.947	32.30%
	C/D	19.19%	11.81%	8.09%	7.38%	113.388	28.19%
	D	15.11%	8.09%	8.09%	7.01%	95.118	23.65%
5	C	21.06%	10.96%	5.18%	10.10%	19.425	20.44%
	D	13.75%	5.18%	5.18%	8.57%	15.101	15.89%

Site	EWR as % of MAR					Long term mean as % of Virgin MAR	
	Category	Total	Maint. Low	Drought	Maint. High	Total Flow	
6	B	34.40%	23.96%	7.21%	10.44%	190.084	34.78%
	C	22.64%	13.96%	7.21%	8.69%	144.054	26.35%
	D	14.71%	7.21%	7.21%	7.51%	116.4	21.30%
7	B	34.18%	23.61%	7.07%	10.57%	186.559	33.22%
	C	22.53%	13.75%	7.07%	8.78%	141.805	25.25%
	D	14.65%	7.07%	7.07%	7.58%	115.503	20.56%

8. REFERENCES

- ¹ Water Research Commission, South Africa (1994). Report No. 298/2.1/94, Surface Water Resources of South Africa 1990, DC Midgley WV Pitman, BJ Middleton,
 - ² DWAF, South Africa (1998). Report PB B910/00/0398, Dec. 1998. The Groot Letaba Water Resource Development, Feasibility Study,
 - ³ DWAF, South Africa (2003). Middle Letaba Water Supply Scheme: Water Conservation and Water Demand Management Situation Assessment Study – Final Version (July 2003). Tlou and Matji (Pty) Ltd.
 - ⁴ Institute for Water Research, (April 2003). SPATSIM – Spatial and Time Series Information Modelling Software, Denis Hughes and David Forsyth,
 - ⁵ DWAF, South Africa (September 2004). Extending the Letaba Hydrology for two selected Quaternary Catchments. PD Naidoo & Associates (Pty) Ltd.
 - ⁶ DWAF, South Africa (1994). Report No. P B800/00/0294. Letaba Water Resource Development : Pre-feasibility. SRK Inc.
 - ⁷ DWAF, South Africa (1994). Development of Operating Rules for the Middle Letaba and Hudson Ntsanwisi Dams in Gazankulu. Eksteen, van der Walt and Nissen (International) (Pty) Ltd. May 1994
 - ⁸ DWAF, South Africa (1990). Report No. P B800/00/0290. Water Resources Planning of the Letaba River Basin : Study of Development Potential and Management of Water Resources. SRK Inc.
-



water & forestry

Department:
Water Affairs and Forestry
REPUBLIC OF SOUTH AFRICA

DIRECTORATE: RESOURCE DIRECTED MEASURES

LETABA RESERVE DETERMINATION

**Extending the Letaba Hydrology for two selected
Quaternary Catchments**

Draft Report

Draft Report



PD Naidoo and Associates No: 02495

DWAF Contract No:

21 September 2004

PROJECT NAME :

Extended Hydrology for the Letaba River Reserve Determination : Pilot Study

REPORT TITLE : **Extending the Letaba Hydrology for two selected Quaternary Catchments**

AUTHOR : Edwin Lillie

REPORT STATUS : Draft Report

DWAF REPORT NO. : -

DATE : September 2004

Submitted on behalf of the PD Naidoo and Associates (Pty) Ltd:

.....
JK Haumann (21 September 2004)
Director : Water Division

DEPARTMENT OF WATER AFFAIRS AND FORESTRY

Directorate: Resource Directed Measures

Sub-Directorate: Reserve Requirements

Approved for Department of Water Affairs and Forestry by:

.....
Name (Date)
Title

STUDY NAME AND REPORT TITLE

Title	Extended Hydrology for the Letaba River Reserve Determination : Pilot Study Extending the Letaba Hydrology for two selected Quaternary Catchments
Author	Edwin Lillie
Status	Draft Report
Date	September 2004

Reason for circulation:

Draft Report to assess the need to extend the available Letaba River Hydrology for determining the Reserve by extending the hydrology of two pilot quaternary catchments.

Circulation list:

Representatives of the Reserve Determination Team for the Letaba River and the Client.

Nature of comments required:

Email using track changes, or hardcopy.

Date for receipt of comments:

As per project schedule.

Sections to be completed:

None

PD Naidoo and Associates (Pty) Ltd
 Bateman Place, 39 Empire Rd, Parktown West, 2198
 Tel: +2711 877 0000; Fax: +2711 482 4717
ken_haumann@pdna.co.za

TABLE OF CONTENTS

TABLE OF CONTENTS	IV
APPENDICES.....	IV
LIST OF ABBREVIATIONS.....	V
LIST OF TABLES.....	V
LIST OF FIGURES	V
1. INTRODUCTION.....	1
1.1 Background	1
1.2 Scope	1
1.3 Approach	2
2. EXTENSION OF THE CATCHMENT RAINFALL RECORDS	3
2.1 Letsitele River (B81D).....	3
2.2 Tsende River (B83B)	4
3. WRSM2000 MODEL CALIBRATION	6
3.1 Letsitele River (B81D).....	6
3.2 Tsende River (B83B)	7
4. STATISTICAL COMPARISON BETWEEN THE ORIGINAL AND THE EXTENDED TIME SERIES	9
4.1 Letsitele River (B81D).....	9
4.2 Tsende River (B83B)	11
5. CONCLUSIONS AND RECOMMENDATIONS.....	12
6. REFERENCES.....	14

APPENDICES

- Appendix A: Catchment Rainfall files as a % of MAP**
- Appendix B: WRSM2000 - Input data**
- Appendix C: WRSM2000 - Output information**
- Appendix D: Monthly Flow Time Series Data**

LIST OF ABBREVIATIONS

DWAF	Department of Water Affairs and Forestry
MAR	Mean Annual Runoff
SAWS	South African Weather Service
SD	Standard Deviation
SI	Seasonal Index
WRSM90	Water Resources Simulation Model 1990
WRSM2000	Water Resources Simulation Model 2000

LIST OF TABLES

Table 1.1:	Available Hydrology for the Letaba Catchment
Table 2.1:	Simulation Catchment Details (B81D)
Table 2.2:	Rainfall Gauges (B81D)
Table 2.3:	Rainfall Gauges (B83B)
Table 3.1:	Final Calibration Parameters (B8H010)
Table 3.2:	Statistics of Observed and Simulated Flow (B8H010) 1974 to 2001
Table 3.3:	Final Calibration Parameters (B8H011)
Table 3.4:	Statistics of Observed and Simulated Flow (B8H011) 1961 to 2000
Table 4.1:	Statistical Comparison between existing and extended time series (nat)
Table 4.2:	Statistical Comparison between existing and extended time series (dev)
Table 4.3:	Statistical Comparison for monthly averages (nat)
Table 4.4:	Statistical Comparison for monthly averages (dev)
Table 4.5:	Statistical Comparison between existing and extended time series (nat)
Table 4.6:	Statistical Comparison for monthly averages (nat)
Table 5.1:	Relative impact of improving and extending the hydrology

LIST OF FIGURES

See appendix B for network diagrams

See appendix C for graphs of observed verses simulated data

1. INTRODUCTION

1.1 Background

The detailed Reserve Determination for the Letaba River is currently being undertaken. In order to make the appropriate Reserve estimates it is important that the Scientists making the estimation have the best information available. One of the most important pieces of information used to determine the Reserve is the naturalised and present day river flow time series.

The hydrology of the Groot Letaba has been historically analysed in detail. However, this work is now over ten years old and does not include the biggest flood in living memory, which occurred in February 2000. The hydrology for the Middle and Klein Letaba was investigated to an intermediate level of detail by DWAF in the late 1990s. Only the regionalised hydrology of the Lower Letaba was done as part of the WR90 study. Table 1.1 below gives a summary of the available hydrology for the Letaba Catchment.

Table 1.1: Available Hydrology for the Letaba River

Tertiary Catchment	Name of River	Available Periods	Source of Data
B81	Groot Letaba	1925-1992	Pre-feasibility Study (SRK/DWAF)
B82	Middel and Klein Letaba	1922-1995	Directorate of Hydrology (DWAF)
B83	Lower Letaba	1920-1989	WR90 (SRK,WLPU, SSI)

Before making the decision to update the hydrology of the whole Letaba catchment for the Reserve determination, it was decided to first extend the hydrology of two quaternary catchments as a pilot study and to then assess the possible impact on the hydrology.

1.2 Scope

The scope of this task involves the updating of the hydrology for two quaternary catchments in the Letaba Catchment in order to assess whether there are significant changes in the level of confidence by using the currently available “older” hydrology. A quaternary in the dry

region and one in a more humid region were selected to be used for extension of the monthly river flow time series.

The deliverable from this task comprises of the extension of the monthly river flow time series for two quaternary catchments and a report containing the information and methods used to do the work as well as recommendations on the way forward.

1.3 Approach

The rainfall catchment file was extended using the same gauges used to generate the original catchment rainfall file on the existing hydrology. Then WRSM2000 was used to extend the catchment runoff file using the original parameters. This was then compared to the gauged information and the model calibration parameters were changed until the simulated and observed flows were within an acceptable range. The catchment runoff file was then generated using the new parameters for naturalised and developed conditions. The extended runoff time series were then statistically compared to the original runoff files. From these observations, recommendations on the way forward could be made.

For the humid area, Quaternary Catchment B81D (Letsitele River) was selected for the hydrology to be extended for the following reasons:

- **The WRSM90 network and data files were available from the pre-feasibility study (note : not all of the quaternary catchments network files could be found);**
- **There is a reliable gauge with a fairly long record at the outlet of the quaternary (B8H010);**
- **It is a headwater catchment.**
- **Average Catchment MAP = 832mm, ranging from 1250mm to 700mm.**
- **There is a reasonable level of development in the catchment (farm dams, forestry, irrigation)**
- **There are no major dams in the catchment.**

For the dryer area, Quaternary Catchment B83B (Tsende River) was selected for the hydrology to be extended for the following reasons:

- **There is a gauge at the outlet of the quaternary (B8H011);**
- **It is a headwater catchment.**
- **Average Catchment MAP = 596mm.**

2. EXTENSION OF THE CATCHMENT RAINFALL RECORDS

The existing catchment rainfall files were extended using the same rainfall gauges that was used to generate the original catchment rainfall files. B81D, which has a catchment rainfall file from 1925 to 1992, was augmented with the periods from 1920 to 1924 and from 1993 to 2001. B83B, which has a catchment rainfall file from 1920 to 1989, was augmented with the periods from 1993 to 2001. These dates represent hydrological years from October to September; therefore the last month in the updated analysis is September 2002. This period includes the very wet periods that occurred in February 1996, December 1998 and February 2000. The most extreme of these events was February 2000, which resulted in extensive flooding.

2.1 Letsitele River (B81D)

The detailed hydrology for the Letsitele catchment (B81D) was done as part of the pre-feasibility study in 1994 done by SRK. The quaternary catchment was subdivided into 7 simulation catchments with different runoff characteristics. The details of the simulation catchments are given in Table 2.1 below.

Table 2.1: Simulation Catchment Details (B81D)

Simulation Catchment	Area (km ²)	MAP (mm)	MAE (Symons Pan) (mm)
D10	89	1250	1400
D13	38	1200	1500
D16	110	900	1500
D20	29	1100	1450
D24	30	1100	1450
D28	151	800	1500
D01	31	700	1500
Total	478	-	-

The SAWS gauges used to generate the catchment rainfall file are given in Table 2.2 below. These gauges were selected both on their proximity to the catchment and on their ability to produce a good calibration to the observed streamflow data using the WRSM90 model. The same gauges were used to extend the catchment rainfall file. Although the record length for

some gauges did not extend into the required period, these gauges had been patched by the Water Research Commission (WRC) Project No.1156, (the development of an improved gridded database of annual, monthly and daily rainfall) to July 2000. The WRC patched records were used to create the extended catchment rainfall file.

Table 2.2: Rainfall Gauges (B81D)

Rain Gauge Number	MAP (mm)	Record Length	Latitude	Longitude
0636276 W	989.9	1930-1973	24.06	30.10
0679209 W	1079.4	1960-2000	23.59	30.07
0679267 W	1319.2	1940-2003	23.57	30.09
0679268 W	1228.1	1938-2000	23.58	30.09
0679388 W	799.0	1931-1948	23.58	30.13
0679508 W	716.1	1905-1998	23.58	30.17
0679019 W	1667.4	1923-1995	23.49	30.01
0679141 W	1331.5	1931-2003	23.51	30.05
0679532 W	816.6	1924-1988	23.52	30.18

2.2 Tsende River (B83B)

The detailed hydrology of the Lower Letaba River has never been undertaken. The existing WR90 catchment hydrology is based on a single simulation catchment with an area of 439 km² and an MAP of 596mm.

The rain gauges selected to extend the rainfall record were the same as those used in WR90. The WRC patched records were used to create the extended catchment rainfall file. The SAWS gauges that were used to generate the catchment rainfall file are given in Table 2.3 below. The catchment rainfall files used are given in appendix A.

Table 2.3: Rainfall Gauges (B83B)

Rain Gauge Number	MAP (mm)	Record Length	Latitude	Longitude
0679508 W	716.1	1905-1998	23.58	30.17
0680821 W	401.3	1944-1988	23.41	30.40
0681180 W	403.3	1924-1968	23.60	31.06
0681248 W	470.4	1959-1986	23.38	31.09
0681266 W	480.8	1967-2003	23.56	31.09
0682141 W	491.1	1927-1989	23.51	31.35

3. WRSM2000 MODEL CALIBRATION

WRSM2000 was used to generate the runoff from catchments B81D and B83B using the extended catchment rainfall file.

3.1 Letsitele River (B81D)

The WRSM network and data files from the pre-feasibility study were used to set up the WRSM2000 model. Appendix B shows the network diagram and the input files. In the feasibility study the catchment runoff was calibrated against the gauge B8H010 for the period from 1974 to 1992. The period prior to 1974 was reviewed and found to have too many gaps. For this period the selected calibration parameters used in the model simulated flows very close to the observed flows.

WRSM2000 was used to simulate the flows using the extended catchment rainfall file and the calibration parameters determined during the feasibility study. The simulated flows were compared to the observed flows at gauge B8H010 for the period from 1974 to 2001. The simulated flows did not compare very well to the observed flows for this period. Many attempts to calibrate the model to obtain a realistic simulation failed. The main problem was the model was not able to simulate the flood that occurred in February 2000. The extended catchment rainfall file was then revised so that the period from 1993 to 1999 was based only on rain gauge number 0636276 W, as this gauge recorded a much higher rainfall peak for Feb 2000 than the other gauges. This high peak correlated with the high peak occurring at the streamflow gauge B8H010. Using the revised catchment rainfall record, the WRSM2000 model was recalibrated and found to correlate very closely with the observed streamflow data. The final calibration parameters are presented in Table 3.1 and the statistics of the observed and simulated flow are given in Table 3.2.

Table 3.1: Final Calibration Parameters (B8H010)

	POW	SL	ST	FT	GW	Zmin	Zmax	PI	TL	GL	R
D10	2.0	0.0	750	67	0.0	50	1100	1.5	0.40	0.0	0.5
D13	2.0	0.0	750	40	0.0	50	1100	1.5	0.40	0.0	0.5
D16	2.0	0.0	600	15	0.0	50	1000	1.5	0.25	0.0	0.5
D20	2.0	0.0	750	56	0.0	50	1100	1.5	0.40	0.0	0.5
D24	2.0	0.0	750	42	0.0	50	1100	1.5	0.40	0.0	0.5
D28	2.0	0.0	250	0	0.0	50	800	1.5	0.25	0.0	0.5
D01	2.0	0.0	250	0	0.0	50	800	1.5	0.25	0.0	0.5

Table 3.2: Statistics of Observed and Simulated Flow (B8H010) 1974 to 2001

Statistics	Observed Flow	Simulated Flow	Difference (%)
Mean Annual Runoff ($10^6\text{m}^3/\text{a}$)	75.72	75.86	0.18
Standard Deviation ($10^6\text{m}^3/\text{a}$)	96.98	100.77	3.91
Seasonal Index (%)	41.63	43.59	4.71

WRSM2000 was then used to generate the monthly flows at the outlet of the catchment B81D from 1920 to 2001 for the present day levels of development. The naturalised catchment flows were generated by taking out all the human induced impacts such as forestry, irrigation, dams and water abstractions. The naturalised flows from 1925 to 1992 were very close to those used for the Reserve determination thus far. However, the present day flows varied slightly, due to the fact that the present day flows were previously generated by the WRYM model, which has different modelling capabilities.

3.2 Tsende River (B83B)

The WRSM network and data files were set up for the WRSM2000 model. Appendix B shows the network diagram and the input files. In the WR90 study, the catchment runoff was calibrated against the gauge B8H011, for the period from 1961 to 1987. The period from 1973 to 1980 was missing. For this period the selected calibration parameters used in the model simulated flows very close to the observed flows.

WRSM2000 was used to simulate the flows using the extended catchment rainfall file and the calibration parameters determined during the WR90 study. The simulated flows were compared to the observed flows at gauge B8H011 for the period from 1961 to 2000. The simulated flows did not compare well to the observed flows for this period. The model was recalibrated until the simulated flows matched the observed record fairly closely. The final calibration parameters are presented in Table 3.3 and the statistics of the observed and simulated flow are given in Table 3.4.

Table 3.3: Final Calibration Parameters (B8H011)

	POW	SL	ST	FT	GW	Zmin	Zmax	PI	TL	GL	R
B83B	0.0	0.0	625	0.0	0.0	150	800	1.5	0.25	0.0	0.0

Table 3.4: Statistics of Observed and Simulated Flow (B8H011) 1961 to 2000

Statistics	Observed Flow	Simulated Flow	Difference (%)
Mean Annual Runoff (10⁶m³/a)	3.90	3.80	-2.56
Standard Deviation (10⁶m³/a)	10.15	12.77	25.81
Seasonal Index (%)	67.40	65.41	-2.95

WRSM2000 was then used to generate the naturalised monthly flows at the outlet of the catchment B83B from 1920 to 2001. The naturalised flows are equal to the developed flows as there were no human impacts assumed for the catchment for modelling purposes. The monthly time series currently being used for the Reserve determination for this quaternary are based on regional parameters and not calibrated parameters for the specific catchment.

4. STATISTICAL COMPARISON BETWEEN THE ORIGINAL AND THE EXTENDED TIME SERIES

A statistical comparison has been made between the currently available hydrology used for the IFR determination and the extended, plus recalibrated, hydrology to determine if there are any significant differences.

4.1 Letsitele River (B81D)

A summary of the differences between the existing and the extended time series are given in Table 4.1 below. The results indicate very much as expected. There is a 4% higher MAR and a 21% higher standard deviation of the mean annual runoff for the naturalised flow. This can be attributed to the very wet years that occurred from 1995 to 1999 (hydrological years). The wettest hydrological year in the record is 1999, due to the very heavy rain that occurred in February/March 2000.

Table 4.1 Statistical Comparison between existing and extended time series (naturalised)

Statistics	Existing 1925 to 1992	New 1920 to 2001	Difference (%)
Mean Annual Runoff ($10^6\text{m}^3/\text{a}$)	85.97	89.64	4.27
Standard Deviation ($10^6\text{m}^3/\text{a}$)	65.67	79.25	20.68
Seasonal Index (%)	30.31	30.01	-0.99

Table 4.2 Statistical Comparison between existing and extended time series (present day)

Statistics	Existing 1925 to 1992	New 1920 to 2001	Difference (%)
Mean Annual Runoff ($10^6\text{m}^3/\text{a}$)	61.22	64.76	5.78
Standard Deviation ($10^6\text{m}^3/\text{a}$)	64.35	78.38	21.80
Seasonal Index (%)	41.39	40.61	-1.88

Note: The values in Tables 4.1 and 4.2 were all generated by WRSM2000, the period from 1920 to 1989 was generated using the updated parameters and the period from 1925 to 1992 was generated using the original pre-feasibility parameters.

Table 4.3 Statistical Comparison for monthly averages (naturalised)

Month	Mean Annual Runoff ($10^6\text{m}^3/\text{a}$)			Standard Deviation ($10^6\text{m}^3/\text{a}$)		
	1925-1995	1920-2001	Difference	1925-1995	1920-2001	Difference
October	2.47	2.62	6.24%	0.86	0.91	6.20%
November	3.23	3.4	5.30%	2.16	2.34	8.22%
December	6.37	6.32	-0.82%	7.17	6.49	-9.56%
January	12.37	11.49	-7.14%	14.24	12.72	-10.70%
February	18.43	20.09	9.03%	26.21	35.37	34.96%
March	15.22	16.28	6.97%	18.63	24.19	29.80%
April	8.73	8.92	2.17%	6.51	6.99	7.41%
May	5.66	5.89	4.05%	2.24	2.39	6.91%
June	4.41	4.69	6.41%	1.49	1.70	14.18%
July	3.60	3.88	7.83%	1.13	1.34	18.71%
August	3.01	3.27	8.68%	0.89	1.08	20.61%
September	2.56	2.79	8.81%	0.74	0.88	18.74%
Total	86.06	89.64	4.16%	-	-	-

Table 4.4 Statistical Comparison for monthly averages (present day development)

Month	Mean Annual Runoff ($10^6\text{m}^3/\text{a}$)			Standard Deviation ($10^6\text{m}^3/\text{a}$)		
	1925-1995	1920-2001	Difference	1925-1995	1920-2001	Difference
October	0.88	0.88	0.23%	0.75	1.00	33.96%
November	1.53	1.67	9.02%	1.84	2.29	24.64%
December	4.08	3.56	-12.64%	6.53	6.40	-2.05%
January	10.14	9.23	-8.98%	13.14	12.20	-7.15%
February	16.05	17.56	9.41%	25.07	34.72	38.52%
March	13.10	13.89	6.04%	17.76	23.79	33.91%
April	6.85	7.21	5.19%	6.18	6.83	10.44%
May	3.82	4.11	7.48%	2.18	2.45	12.51%
June	2.87	2.97	3.61%	1.50	1.80	19.56%
July	2.17	1.99	-8.49%	1.13	1.37	21.31%
August	1.07	1.01	-5.18%	0.80	0.97	22.11%
September	0.83	0.68	-18.07%	0.65	0.80	22.47%
Total	63.39	64.76	2.17%	-	-	-

Note: The values in Tables 4.3 and 4.4 from 1920-2001 were generated by WRSM2000. The values from 1925-1992 (nat.) are from the pre-feasibility hydrology and the 1925-1992 (dev.) were generated using WRYM.

4.2 Tsende River (B83B)

A summary of the differences between the existing and the extended time series are given in Table 4.5 below. The results are very different from the WR90 regional runoff values. This is mainly due to the fact that the WR90 values are based on regional parameters, where the latest extended values are based on calibrated parameters that are based on the observed flow at gauge B8H011.

Table 4.5 Statistical Comparison between existing and extended time series (naturalised)

Statistics	Existing 1920 to 1989	New 1920 to 2001	Difference (%)
Mean Annual Runoff ($10^6\text{m}^3/\text{a}$)	8.55	5.42	-36.61
Standard Deviation ($10^6\text{m}^3/\text{a}$)	15.91	13.40	-15.78
Seasonal Index (%)	60.03	63.43	5.66

Note: The values in Tables 4.5 were all generated by WRS2000. The period from 1920 to 2001 was generated using the updated parameters and the period from 1920 to 1989 was generated using the WR90 regional parameters.

Table 4.6 Statistical Comparison for monthly averages (naturalised)

Month	Mean Annual Runoff ($10^6\text{m}^3/\text{a}$)			Standard Deviation ($10^6\text{m}^3/\text{a}$)		
	1920-1989	1920-2001	Difference	1920-1989	1920-2001	Difference
October	0.02	0.00	-100.00%	0.08	0.02	-73.63%
November	0.12	0.04	-66.51%	0.35	0.17	-52.79%
December	0.79	0.43	-45.62%	2.42	1.80	-25.53%
January	2.48	1.55	-37.48%	8.60	6.68	-22.33%
February	2.87	2.24	-22.04%	7.33	7.71	5.16%
March	1.86	1.01	-45.76%	5.33	3.02	-43.33%
April	0.41	0.15	-63.45%	1.67	0.59	-64.83%
May	0.01	0.00	-100.00%	0.05	0.02	-65.07%
June	0.00	0.00	0.00%	0.00	0.00	0.00%
July	0.00	0.00	0.00%	0.00	0.00	0.00%
August	0.00	0.00	0.00%	0.00	0.00	0.00%
September	0.01	0.00	-100.00%	0.09	0.03	-69.21%
Total	8.58	5.42	-36.81%	-	-	-

Note: The values in Tables 4.6 were generated by WRS2000 for 1920-2001, whereas the values from 1920 to 1989 are from WR90.

5. CONCLUSIONS AND RECOMMENDATIONS

5.1 B81D

Extending and recalibrating the simulated naturalised flow time series for the **Letsitele catchment (B81D)**, results in an estimated **4% increase in MAR** and a **20% increase in the standard deviation of the MAR**. The monthly variation in runoff was up to 9% more and the monthly standard deviation was up to 35% more for February. This is attributed to the wet cycle that occurred in the late 1990s particularly the 1999 hydrological year in which the annual runoff was 6 times greater than the average, with the bulk of the runoff occurring in Feb 2000. By extending the hydrology, the modeller has the opportunity to recalibrate the WRSM2000 model, with a longer observed flow record. The observed record used in the pre-feasibility study was from 1972 to 1992 (21 years), which for this exercise was extended to 2001 (30 years). This gives the modeller over 40% more data with which to perform the calibration, leading to higher confidence to the results.

The low flow hydrology has not changed significantly. The higher variability in the MAR is a product of adding the wetter hydrological years, which has tended to yield a greater variability in the high flows.

5.2 B83B

Extending and recalibrating the simulated naturalised flow time series for the **Tsende catchment (B83B)**, results in an estimated **36% decrease in MAR** and a **15% decrease in the standard deviation of the MAR**. The monthly variation in runoff was up to 60% less and the monthly standard deviation was up to 65% less. This is attributed to the difference between the regionalised parameters used in WR90 and the detailed calibration done using gauge B8H011. The existing regionalised flows used to date in the IFR study for B83D are considered to be a fairly poor representation of the hydrology of this catchment.

Both the low flows and high flows have changed significantly due to the decrease in MAR.

Table 5.1: Relative impact of improving and extending the hydrology

Tertiary Catchment	Name of River	Available Periods	Origin of Data	Confidence in existing data	Source of Data	MAR as a % of the Total
B81	Groot Letaba	1925-1992	Detailed assessment made in 1994	Medium (data ten years out of date)	Pre-feasibility Study (SRK/DWAF)	66.6 %
B82	Middel and Klein Letaba	1922-1995	Intermediate assessment made in late 1990s	Medium to Low	Directorate of Hydrology (DWAF)	26.5 %
B83	Lower Letaba	1920-1989	Regional assessment made in the early 1990s	Low	WR90 (WRC-SRK,WLPU, SSI)	7.2 %

The main consequences of extending the hydrology throughout the Letaba catchment would be:

- to improve the confidence in all flows in tertiary catchments B82 and B83
- to improve the confidence in the high flows in tertiary catchment B81
- to improve present day flow generation from the yield model
- to improve scenario planning using the planning model with improved stochastic hydrology

The bulk of the runoff from the Letaba Catchment is generated from the Groot Letaba tertiary catchment B81. This study has indicated that the available hydrology from this catchment is reasonably reliable, but that the variability of high flows has increased.

For the purposes of the comprehensive Letaba Reserve Determination, with only one IFR site (IFR5) representing the Middel and Klein Letaba and 6 sites on the main stem, it is concluded that the relative importance of improving the confidence in the high flows for the Groot Letaba should dictate whether the entire hydrology for the Letaba catchment needs to be extended.

6. REFERENCES

- DWAF (1990) **Water Resources Planning of the Letaba River Basin.** Study of development potential and management of the water resources. Consultant: SRK
- DWAF (1990) **Kruger National Park Rivers Research Programme, Water for Nature.** Hydrology Letaba River Catchment.. Consultant: SRK
- WRC (1994) **Surface Water Resources of South Africa 1990.** Water Research Commission, Pretoria, South Africa, Report No. 298/1.1/94
Authors DC Midgley, WV Pitman and BJ Middleton.
- DWAF (1994) **Letaba Water Resource Development.** Pre-Feasibility Study. Consultant: SRK
- DWAF (1996) **Letaba River IFR Workshop report.**
- DWAF (1998) **The Groot Letaba Water Resource Development.** Feasibility Study. Consultant: BKS and Consultburo
- DWAF **DWAF Internal Investigation of the Middel and Klein Letaba.** By sub-directorate Hydrology.
- WRC (2003) **The Development of an Improved Gridded Database of Annual, Monthly and Daily Rainfall.** Water Research Commission, Pretoria, South Africa, Report No. 1156/0/1
Author Lynch, S.D.
- DWAF (1999) **Water Resources Yield Model: User Guide- Release 4.1.1.** June 1999. Report No. P0000/00/001/98 compiled by BKS Pty (Ltd) for the Department of Water Affairs and Forestry, Pretoria, South Africa.
Author: McKenzie RS and Van Rooyen, PG.
- DWAF (1994) **Probabilistic Management of Water Resource and Hydropower Systems** by MS Basson, RB Allen, GGS Pegram and JA van Rooyen. Published by Water Resources Publications, ISBN Number 918334-89-6

Appendix A
Catchment Rain Files as a % of MAP

1

AVERAGE RAINFALL ON CATCHMENT OF GAUGE B81D

SECTION		DETAILS OF RAINFALL STATIONS USED					
POSITION	MAP(mm)	PERIOD OF RECORD	LATITUDE	LONGITUDE			
636	276	990	1993 TO 1999	24.06	30.10		
679	209	1079	1993 TO 2000	23.59	30.07		
679	267	1319	1993 TO 2001	23.57	30.09		
679	268	1228	1993 TO 1999	23.58	30.09		
679	388	799	1993 TO 1999	23.58	30.13		
679	508	716	1993 TO 1999	23.58	30.17		
679	19	1667	1993 TO 1999	23.49	30.01		
679	141	1332	1993 TO 2001	23.51	30.05		
679	532	817	1993 TO 1999	23.52	30.18		

NO.	GAUGES	OCT	NOV	DEC	JAN	FEB	MAR	APR	MAY	JUN	JUL	AUG	SEP	YEAR
1993	9	4.45	16.09	18.89	10.01	12.63	7.16	3.44	.29	.02	.14	.66	.86	74.64
1994	9	8.31	5.38	13.45	14.00	11.86	13.87	7.96	2.93	.03	.10	.88	1.06	79.83
1995	9	3.61	25.94	22.01	27.75	46.69	9.97	7.18	10.05	1.73	4.74	4.20	1.15	165.01
1996	9	6.54	12.39	14.59	28.83	16.34	26.29	4.03	2.32	.15	.84	.23	7.57	120.11
1997	9	7.25	15.40	9.79	24.89	5.57	4.24	3.52	.00	.09	4.98	1.05	3.69	80.47
1998	9	10.03	13.10	27.31	25.61	16.57	19.29	6.88	3.91	1.26	2.86	.42	1.16	128.40
1999	9	3.56	15.32	20.08	28.82	49.70	32.91	10.63	1.86	7.57	.44	.69	4.95	176.52
2000	3	8.43	9.07	20.15	4.85	29.78	9.16	2.78	2.67	1.30	.72	.32	1.74	90.95
2001	2	9.91	32.50	17.90	11.04	8.11	2.89	3.14	.29	3.79	.37	1.19	2.56	93.68
AVERAGE		6.90	16.13	18.24	19.53	21.92	13.98	5.51	2.70	1.77	1.69	1.07	2.75	112.18
ADJUSTED		6.15	14.38	16.26	17.41	19.54	12.46	4.91	2.41	1.58	1.50	.96	2.45	100.00
STD.DEV.		2.39	7.84	4.85	8.91	15.46	9.67	2.59	2.89	2.35	1.87	1.15	2.15	35.76

1

AVERAGE RAINFALL ON CATCHMENT OF GAUGE B83D

SECTION		DETAILS OF RAINFALL STATIONS USED					
POSITION	MAP(mm)	PERIOD OF RECORD	LATITUDE	LONGITUDE			
679	508	716	1990 TO 1999	23.58	30.17		
680	281	401	1990 TO 1999	23.41	30.40		
681	180	403	1990 TO 1999	23.60	31.06		
681	248	470	1990 TO 1999	23.38	31.09		
681	266	481	1990 TO 2001	23.56	31.09		
682	141	491	1990 TO 1999	23.51	31.35		

NO.	GAUGES	OCT	NOV	DEC	JAN	FEB	MAR	APR	MAY	JUN	JUL	AUG	SEP	YEAR
1990	6	6.17	11.70	23.05	21.31	11.24	13.39	.80	1.83	1.73	.04	.00	.97	92.24
1991	6	.30	10.86	4.23	8.31	1.60	6.17	1.00	.05	2.36	.00	.89	.11	35.89
1992	6	1.27	12.74	29.59	14.20	8.51	7.53	4.16	.64	.19	1.17	.52	.11	80.64
1993	6	2.78	19.27	16.72	10.49	4.05	5.95	3.87	.39	.04	.12	.75	2.39	66.82
1994	6	7.62	7.10	16.55	24.47	11.21	9.88	12.06	3.33	.09	.00	1.07	.77	94.15
1995	6	6.82	12.32	17.16	31.13	41.34	10.19	10.09	8.56	.85	7.05	1.76	2.87	150.14
1996	6	5.75	13.75	15.60	25.47	18.87	11.59	4.79	3.36	.04	.00	.56	7.56	107.36
1997	6	6.42	23.08	6.99	19.10	2.51	3.98	2.57	.07	.00	1.77	.83	3.26	70.59
1998	6	10.63	17.07	34.74	25.70	23.85	13.93	7.06	1.83	.31	3.06	.30	1.64	140.13
1999	6	5.23	18.43	18.39	32.34	81.84	29.30	7.07	2.51	2.37	1.05	.00	2.65	201.18
2000	1	6.49	9.28	10.15	12.10	37.35	18.59	9.23	.71	4.08	.04	.00	.00	108.03
2001	1	8.28	25.37	8.90	10.02	.75	3.45	3.58	.00	2.87	.00	.04	2.12	65.39
AVERAGE		5.65	15.08	16.84	19.55	20.26	11.16	5.52	1.94	1.25	1.19	.56	2.04	101.04
ADJUSTED		5.59	14.93	16.66	19.35	20.05	11.05	5.47	1.92	1.23	1.18	.55	2.01	100.00
STD.DEV.		2.81	5.35	8.61	8.07	22.64	6.93	3.45	2.32	1.33	1.99	.52	1.99	43.02

AVERAGE RAINFALL ON CATCHMENT OF CODE

SECTION		DETAILS OF RAINFALL STATIONS USED					
POSITION	MAP(mm)	PERIOD OF RECORD	LATITUDE	LONGITUDE			
636	276	990	1993 TO 1999	24.06	30.10		

YEAR	STNS.	OCT	NOV	DEC	JAN	FEB	MAR	APR	MAY	JUN	JUL	AUG	SEP	YEAR
1993	1	2.95	14.75	18.13	3.68	18.38	7.61	6.37	0.52	0.07	0.03	1.00	0.57	74.05
1994	1	6.55	5.10	11.80	12.80	16.48	9.53	9.11	1.83	0.06	0.00	0.56	1.10	74.91
1995	1	3.39	17.37	17.43	24.97	53.84	7.31	7.35	8.51	1.29	6.65	3.38	0.81	152.31
1996	1	6.48	11.35	25.71	29.80	16.64	21.77	3.74	2.09	0.31	0.53	0.05	6.59	125.05
1997	1	8.32	9.85	9.87	20.61	6.91	4.20	3.86	0.00	0.00	4.17	0.81	3.59	72.19
1998	1	7.55	13.99	34.26	20.46	11.02	16.74	6.13	3.82	2.16	5.02	0.05	0.88	122.07
1999	1	3.70	16.33	25.10	30.70	90.96	31.28	8.87	1.56	10.63	0.56	0.72	5.15	225.55
AVERAGE		5.56	12.68	20.33	20.43	30.60	14.06	6.49	2.62	2.08	2.42	0.94	2.67	120.88
ADJUSTED		4.60	10.49	16.82	16.90	25.32	11.63	5.37	2.16	1.72	2.00	0.78	2.21	100.00
STD.DEV.		2.01	3.94	7.94	8.89	28.47	9.01	2.00	2.66	3.57	2.57	1.05	2.26	51.60

Extended Catchment Rainfall file as a % of MAP for B81D (all gauges used)

	Year	Oct	Nov	Dec	Jan	Feb	Mar	Apr	May	Jun	Jul	Aug	Sep
B81D	1920	6.71	9.54	20.69	24.28	14.95	20.08	1.09	1.5	3.03	0	0.09	1.98
B81D	1921	1.47	8.19	6.57	6.37	3.29	8.23	1.58	0	0.67	0.13	0.98	1.21
B81D	1922	2.74	6.02	21.18	5.76	7.38	15.68	2.76	0.71	0.82	1.07	0.89	1.49
B81D	1923	4.45	16.09	18.89	10.01	12.63	7.16	3.44	0.29	0.02	0.14	0.66	0.86
B81D	1924	8.31	5.38	13.45	14	11.86	13.87	7.96	2.93	0.03	0.1	0.88	1.06
B81D	1925	3.24	7.44	8.75	16.33	22.99	14.96	1.14	1.49	0.12	5.61	0.17	1.98
B81D	1926	0.45	6.65	7.24	14.26	6.3	4.39	3.57	1.22	0.62	2.74	2.18	1.02
B81D	1927	19.17	7.71	12.25	38.97	8.28	4.35	6.44	0.88	0	0.75	2.25	1.49
B81D	1928	2.89	16.18	9.22	15.9	21.48	18.91	3.97	0.09	1.81	1.2	1.32	2.29
B81D	1929	7.52	13.28	18.14	11.23	14.03	21.1	10.05	1.03	1.59	1.74	0.28	2.82
B81D	1930	0.08	7.73	37.76	20.6	11.05	13.55	15.09	0.05	0.65	7.86	0.05	1.17
B81D	1931	2.29	16.16	10.54	14.45	8.36	10.56	5.03	4.41	0.32	0	0	1.03
B81D	1932	3.84	5.25	17.12	35.09	10.35	7.7	3.53	0.23	0.02	0.78	0.74	0.74
B81D	1933	2.98	30.75	16.99	29.22	12.81	10.52	4.86	1.04	1.75	0.62	0.68	1.83
B81D	1934	4.63	14.28	20.5	12.87	10.01	5.09	1.64	4.99	0.49	2.18	0.08	2.35
B81D	1935	4.13	1.22	9.92	18.32	24.09	17.11	5.03	5.13	1.2	1.03	0.58	5.61
B81D	1936	5.87	18.03	17.01	24.65	42.33	10.16	2.05	0.17	0.07	0.89	0.55	2.67
B81D	1937	2.3	3.29	20.73	21.69	6.36	5.08	26.41	1.49	3.09	0.93	0.55	6.97
B81D	1938	20.11	8.5	40.75	24.21	38.18	20.38	2.93	4.42	1.76	6.85	1.5	8.35
B81D	1939	3.57	29.4	21.84	7.47	8.76	20.87	9.58	0.91	6.22	0.04	1.88	7.74
B81D	1940	4.18	15.04	23.17	6.31	8.29	5.88	19.19	0.15	0.08	0.18	1.23	0.74
B81D	1941	3.93	6.24	15.13	12.9	4.88	25.76	2.83	4.12	2.26	0.82	1.84	6.34
B81D	1942	7.97	9.23	14.15	5.67	9.29	19.23	24.43	1.38	0	4.59	6.97	3.58
B81D	1943	1.64	11.45	7.76	17.34	38.07	8.6	2.26	0.08	5.15	0.01	0.54	1.21
B81D	1944	15.69	7.09	6.81	19.99	20.42	12.08	4.31	0.02	0	0.85	0.27	0.22
B81D	1945	9.35	5.36	10.84	41.53	19.7	11.91	3.06	0.7	0.37	0.07	0.42	0.07
B81D	1946	4.05	8.15	6.51	9.17	24.06	11.93	7.87	0.89	1.06	0.95	0.08	1.81
B81D	1947	4.61	14.01	23.32	14.92	13.26	44.15	4.26	1.51	0.04	0.57	0.11	1.32
B81D	1948	12.28	8.98	7.78	29.91	13.61	5.32	3.39	4.31	2.96	1.21	0.3	2.27
B81D	1949	1.81	12.7	17.62	12.12	16.63	17.12	10.44	5.35	0.72	0.47	1.22	1.3
B81D	1950	0.88	8.35	35.75	9.76	3.23	10.42	7.86	11.73	0	0.36	2.92	4.16
B81D	1951	12.09	3.39	8.89	8.66	9.57	5.26	5.57	1.32	1.51	3.18	0.89	0.55
B81D	1952	4.58	15.27	20.66	32.22	38.26	14.85	10.4	1.06	0	1.5	1.09	0.63
B81D	1953	2.57	15.45	16.08	25.46	19.87	6.53	8.33	2	0.39	0	3.04	0.82
B81D	1954	4.86	15.87	17.61	37.92	50.87	19.4	8.54	3.13	2	1.1	0.05	1.25
B81D	1955	9.56	18.11	29.95	9.78	60.18	19.5	2.59	4.92	3.54	0.44	0.82	8.98
B81D	1956	3.26	7.46	12.79	10.21	15.16	21.25	6.44	2.47	1.82	5.93	3.32	3.93
B81D	1957	11.12	6.46	8.65	47.01	6.93	7.49	6.5	0.1	0.5	0.23	0.02	9.46
B81D	1958	4.24	11.65	22.92	18.29	14.38	8.34	1.52	0.5	0.55	1.95	0.14	2.06
B81D	1959	5.31	18.23	19.75	5.96	21.56	7.19	9.19	2.17	2.44	0.24	0.77	3.1
B81D	1960	2.25	27.91	36.71	6.36	23.89	19.37	11.58	1.26	5.75	3.52	2.52	3.2
B81D	1961	2.53	6.53	11	13.21	8.85	5.48	7.42	1.57	0.13	0.14	0.06	0.37
B81D	1962	1	17.52	18.57	10.17	3.36	5.3	5.92	3.61	6.33	2.05	0.53	0.99
B81D	1963	4.49	8.67	12	12.19	9.95	1.9	4.34	1.51	0.02	0	0.13	1.59
B81D	1964	10.89	9.32	31.83	21	9.77	4.11	5.92	0.67	0.5	0.14	0.68	4.56
B81D	1965	2.54	9.67	6.65	21.71	20.94	2.53	2.2	0.24	1.09	0.54	0.93	3.02
B81D	1966	8.24	6.58	16.54	15.91	24.52	15.14	16.76	1.19	0.16	1.46	0.64	0.2
B81D	1967	5.34	13.56	8.65	4.69	9.3	13.33	8.22	5.45	3.7	1.13	1.05	0.57
B81D	1968	4.39	13.98	20.32	19.7	5.64	25.19	6.48	1.01	0.92	0.92	0.54	2.51
B81D	1969	18.68	7.77	17.96	5.67	10.85	3.17	2.13	2.42	1.51	2.37	0.16	1.42
B81D	1970	6.05	9.65	15.95	25.76	8.14	6.67	14.19	3.18	1.08	0	0.13	1.6
B81D	1971	11.64	13.64	14.38	51.04	28.06	25.09	4.08	4.62	0.23	0.2	1.45	0.5

B81D	1972	12.3	10	5.64	8.63	8.62	8.87	9.01	2.41	0.23	2.03	0.7	14.38
B81D	1973	11.35	14.15	25.45	28.53	29.12	15.75	6.59	2.09	0.12	4.21	1.47	7.87
B81D	1974	3.54	14.96	17.75	23.48	22.89	11.18	5.99	2.87	1.16	0.03	0.76	0.83
B81D	1975	2.59	7.05	33.94	37.85	20.26	30.45	6.43	10.26	0.44	0.02	0.47	0.8
B81D	1976	5.29	13.95	5.31	29.18	18	25.39	5.69	2.02	0.07	0	1.54	8.42
B81D	1977	2.78	9.56	18.4	40.65	18.8	16.59	3.72	0.81	0.15	1.03	0.47	1.99
B81D	1978	4.99	14.95	9.88	15.51	8.29	12.81	6.16	3.94	0.17	0.66	8.09	2.41
B81D	1979	9.67	11.42	18.89	19.71	33.99	6.57	3.61	0.52	0	1.19	2.29	7.48
B81D	1980	7.32	22.56	19.43	41.6	25.58	15.51	4.02	1.59	0.02	0.26	2.88	2.69
B81D	1981	8.49	13.94	10.8	14.07	2.63	4.13	5.55	5.13	0	1.05	0.57	1.49
B81D	1982	5.29	9.84	9.53	8.43	3.65	11.37	1.36	0.56	1.3	0.16	3.14	0.57
B81D	1983	8.13	12.53	10.99	5.61	7.3	17.94	4.77	0.06	0.45	10.24	1.77	3.92
B81D	1984	12.96	21.8	4.97	18.29	25.75	11.59	0.96	6.07	3.94	1.48	0.28	7.57
B81D	1985	8.92	4.67	12.07	9.91	10.7	7.35	21.38	1.61	0.67	0.04	1.79	1.29
B81D	1986	7.07	13.23	18.13	11.84	15.69	9.44	4.43	2.05	2.46	0	2.65	11.74
B81D	1987	6.76	9	27.94	12.11	31.79	28.04	3.04	0.16	4.69	0.6	1.82	5.25
B81D	1988	16.14	4.59	9.8	8.96	20.25	6.64	4.19	1.07	3.69	0.23	1.32	0.71
B81D	1989	9	15.41	18.51	22.55	16.03	12.46	7.32	1.21	0.16	1.12	0.67	0.41
B81D	1990	6.97	9.62	19.5	26.02	15.37	20.06	0.75	1.12	3.04	0	0.16	2.06
B81D	1991	1.07	8.94	5.77	6.6	2.99	7.13	1.14	0	0.57	0.06	1.14	0.62
B81D	1992	2.75	5.52	20.59	5.96	8.46	17.79	2.25	0.86	0.79	1.02	1.09	0.99
B81D	1993	4.45	16.09	18.89	10.01	12.63	7.16	3.44	0.29	0.02	0.14	0.66	0.86
B81D	1994	8.31	5.38	13.45	14	11.86	13.87	7.96	2.93	0.03	0.1	0.88	1.06
B81D	1995	3.61	25.94	22.01	27.75	46.69	9.97	7.18	10.05	1.73	4.74	4.2	1.15
B81D	1996	6.54	12.39	14.59	28.83	16.34	26.29	4.03	2.32	0.15	0.84	0.23	7.57
B81D	1997	7.25	15.4	9.79	24.89	5.57	4.24	3.52	0	0.09	4.98	1.05	3.69
B81D	1998	10.03	13.1	27.31	25.61	16.57	19.29	6.88	3.91	1.26	2.86	0.42	1.16
B81D	1999	3.56	15.32	20.08	28.82	49.7	32.91	10.63	1.86	7.57	0.44	0.69	4.95
B81D	2000	8.43	9.07	20.15	4.85	29.78	9.16	2.78	2.67	1.3	0.72	0.32	1.74
B81D	2001	9.91	32.5	17.9	11.04	8.11	2.89	3.14	0.29	3.79	0.37	1.19	2.56

Extended Catchment Rainfall file as a % of MAP for B81D (0636276 W 93 – 99)

	Year	Oct	Nov	Dec	Jan	Feb	Mar	Apr	May	Jun	Jul	Aug	Sep
B81D	1920	6.71	9.54	20.69	24.28	14.95	20.08	1.09	1.5	3.03	0	0.09	1.98
B81D	1921	1.47	8.19	6.57	6.37	3.29	8.23	1.58	0	0.67	0.13	0.98	1.21
B81D	1922	2.74	6.02	21.18	5.76	7.38	15.68	2.76	0.71	0.82	1.07	0.89	1.49
B81D	1923	4.45	16.09	18.89	10.01	12.63	7.16	3.44	0.29	0.02	0.14	0.66	0.86
B81D	1924	8.31	5.38	13.45	14	11.86	13.87	7.96	2.93	0.03	0.1	0.88	1.06
B81D	1925	3.24	7.44	8.75	16.33	22.99	14.96	1.14	1.49	0.12	5.61	0.17	1.98
B81D	1926	0.45	6.65	7.24	14.26	6.3	4.39	3.57	1.22	0.62	2.74	2.18	1.02
B81D	1927	19.17	7.71	12.25	38.97	8.28	4.35	6.44	0.88	0	0.75	2.25	1.49
B81D	1928	2.89	16.18	9.22	15.9	21.48	18.91	3.97	0.09	1.81	1.2	1.32	2.29
B81D	1929	7.52	13.28	18.14	11.23	14.03	21.1	10.05	1.03	1.59	1.74	0.28	2.82
B81D	1930	0.08	7.73	37.76	20.6	11.05	13.55	15.09	0.05	0.65	7.86	0.05	1.17
B81D	1931	2.29	16.16	10.54	14.45	8.36	10.56	5.03	4.41	0.32	0	0	1.03
B81D	1932	3.84	5.25	17.12	35.09	10.35	7.7	3.53	0.23	0.02	0.78	0.74	0.74
B81D	1933	2.98	30.75	16.99	29.22	12.81	10.52	4.86	1.04	1.75	0.62	0.68	1.83
B81D	1934	4.63	14.28	20.5	12.87	10.01	5.09	1.64	4.99	0.49	2.18	0.08	2.35
B81D	1935	4.13	1.22	9.92	18.32	24.09	17.11	5.03	5.13	1.2	1.03	0.58	5.61
B81D	1936	5.87	18.03	17.01	24.65	42.33	10.16	2.05	0.17	0.07	0.89	0.55	2.67
B81D	1937	2.3	3.29	20.73	21.69	6.36	5.08	26.41	1.49	3.09	0.93	0.55	6.97
B81D	1938	20.11	8.5	40.75	24.21	38.18	20.38	2.93	4.42	1.76	6.85	1.5	8.35
B81D	1939	3.57	29.4	21.84	7.47	8.76	20.87	9.58	0.91	6.22	0.04	1.88	7.74
B81D	1940	4.18	15.04	23.17	6.31	8.29	5.88	19.19	0.15	0.08	0.18	1.23	0.74
B81D	1941	3.93	6.24	15.13	12.9	4.88	25.76	2.83	4.12	2.26	0.82	1.84	6.34
B81D	1942	7.97	9.23	14.15	5.67	9.29	19.23	24.43	1.38	0	4.59	6.97	3.58
B81D	1943	1.64	11.45	7.76	17.34	38.07	8.6	2.26	0.08	5.15	0.01	0.54	1.21
B81D	1944	15.69	7.09	6.81	19.99	20.42	12.08	4.31	0.02	0	0.85	0.27	0.22
B81D	1945	9.35	5.36	10.84	41.53	19.7	11.91	3.06	0.7	0.37	0.07	0.42	0.07
B81D	1946	4.05	8.15	6.51	9.17	24.06	11.93	7.87	0.89	1.06	0.95	0.08	1.81
B81D	1947	4.61	14.01	23.32	14.92	13.26	44.15	4.26	1.51	0.04	0.57	0.11	1.32
B81D	1948	12.28	8.98	7.78	29.91	13.61	5.32	3.39	4.31	2.96	1.21	0.3	2.27
B81D	1949	1.81	12.7	17.62	12.12	16.63	17.12	10.44	5.35	0.72	0.47	1.22	1.3
B81D	1950	0.88	8.35	35.75	9.76	3.23	10.42	7.86	11.73	0	0.36	2.92	4.16
B81D	1951	12.09	3.39	8.89	8.66	9.57	5.26	5.57	1.32	1.51	3.18	0.89	0.55
B81D	1952	4.58	15.27	20.66	32.22	38.26	14.85	10.4	1.06	0	1.5	1.09	0.63
B81D	1953	2.57	15.45	16.08	25.46	19.87	6.53	8.33	2	0.39	0	3.04	0.82
B81D	1954	4.86	15.87	17.61	37.92	50.87	19.4	8.54	3.13	2	1.1	0.05	1.25
B81D	1955	9.56	18.11	29.95	9.78	60.18	19.5	2.59	4.92	3.54	0.44	0.82	8.98
B81D	1956	3.26	7.46	12.79	10.21	15.16	21.25	6.44	2.47	1.82	5.93	3.32	3.93
B81D	1957	11.12	6.46	8.65	47.01	6.93	7.49	6.5	0.1	0.5	0.23	0.02	9.46
B81D	1958	4.24	11.65	22.92	18.29	14.38	8.34	1.52	0.5	0.55	1.95	0.14	2.06
B81D	1959	5.31	18.23	19.75	5.96	21.56	7.19	9.19	2.17	2.44	0.24	0.77	3.1
B81D	1960	2.25	27.91	36.71	6.36	23.89	19.37	11.58	1.26	5.75	3.52	2.52	3.2
B81D	1961	2.53	6.53	11	13.21	8.85	5.48	7.42	1.57	0.13	0.14	0.06	0.37
B81D	1962	1	17.52	18.57	10.17	3.36	5.3	5.92	3.61	6.33	2.05	0.53	0.99
B81D	1963	4.49	8.67	12	12.19	9.95	1.9	4.34	1.51	0.02	0	0.13	1.59
B81D	1964	10.89	9.32	31.83	21	9.77	4.11	5.92	0.67	0.5	0.14	0.68	4.56
B81D	1965	2.54	9.67	6.65	21.71	20.94	2.53	2.2	0.24	1.09	0.54	0.93	3.02
B81D	1966	8.24	6.58	16.54	15.91	24.52	15.14	16.76	1.19	0.16	1.46	0.64	0.2
B81D	1967	5.34	13.56	8.65	4.69	9.3	13.33	8.22	5.45	3.7	1.13	1.05	0.57
B81D	1968	4.39	13.98	20.32	19.7	5.64	25.19	6.48	1.01	0.92	0.92	0.54	2.51
B81D	1969	18.68	7.77	17.96	5.67	10.85	3.17	2.13	2.42	1.51	2.37	0.16	1.42
B81D	1970	6.05	9.65	15.95	25.76	8.14	6.67	14.19	3.18	1.08	0	0.13	1.6

B81D	1971	11.64	13.64	14.38	51.04	28.06	25.09	4.08	4.62	0.23	0.2	1.45	0.5
B81D	1972	12.3	10	5.64	8.63	8.62	8.87	9.01	2.41	0.23	2.03	0.7	14.38
B81D	1973	11.35	14.15	25.45	28.53	29.12	15.75	6.59	2.09	0.12	4.21	1.47	7.87
B81D	1974	3.54	14.96	17.75	23.48	22.89	11.18	5.99	2.87	1.16	0.03	0.76	0.83
B81D	1975	2.59	7.05	33.94	37.85	20.26	30.45	6.43	10.26	0.44	0.02	0.47	0.8
B81D	1976	5.29	13.95	5.31	29.18	18	25.39	5.69	2.02	0.07	0	1.54	8.42
B81D	1977	2.78	9.56	18.4	40.65	18.8	16.59	3.72	0.81	0.15	1.03	0.47	1.99
B81D	1978	4.99	14.95	9.88	15.51	8.29	12.81	6.16	3.94	0.17	0.66	8.09	2.41
B81D	1979	9.67	11.42	18.89	19.71	33.99	6.57	3.61	0.52	0	1.19	2.29	7.48
B81D	1980	7.32	22.56	19.43	41.6	25.58	15.51	4.02	1.59	0.02	0.26	2.88	2.69
B81D	1981	8.49	13.94	10.8	14.07	2.63	4.13	5.55	5.13	0	1.05	0.57	1.49
B81D	1982	5.29	9.84	9.53	8.43	3.65	11.37	1.36	0.56	1.3	0.16	3.14	0.57
B81D	1983	8.13	12.53	10.99	5.61	7.3	17.94	4.77	0.06	0.45	10.24	1.77	3.92
B81D	1984	12.96	21.8	4.97	18.29	25.75	11.59	0.96	6.07	3.94	1.48	0.28	7.57
B81D	1985	8.92	4.67	12.07	9.91	10.7	7.35	21.38	1.61	0.67	0.04	1.79	1.29
B81D	1986	7.07	13.23	18.13	11.84	15.69	9.44	4.43	2.05	2.46	0	2.65	11.74
B81D	1987	6.76	9	27.94	12.11	31.79	28.04	3.04	0.16	4.69	0.6	1.82	5.25
B81D	1988	16.14	4.59	9.8	8.96	20.25	6.64	4.19	1.07	3.69	0.23	1.32	0.71
B81D	1989	9	15.41	18.51	22.55	16.03	12.46	7.32	1.21	0.16	1.12	0.67	0.41
B81D	1990	6.97	9.62	19.5	26.02	15.37	20.06	0.75	1.12	3.04	0	0.16	2.06
B81D	1991	1.07	8.94	5.77	6.6	2.99	7.13	1.14	0	0.57	0.06	1.14	0.62
B81D	1992	2.75	5.52	20.59	5.96	8.46	17.79	2.25	0.86	0.79	1.02	1.09	0.99
B81D	1993	2.95	14.75	18.13	3.68	18.38	7.61	6.37	0.52	0.07	0.03	1	0.57
B81D	1994	6.55	5.1	11.8	12.8	16.48	9.53	9.11	1.83	0.06	0	0.56	1.1
B81D	1995	3.39	17.37	17.43	24.97	53.84	7.31	7.35	8.51	1.29	6.65	3.38	0.81
B81D	1996	6.48	11.35	25.71	29.8	16.64	21.77	3.74	2.09	0.31	0.53	0.05	6.59
B81D	1997	8.32	9.85	9.87	20.61	6.91	4.2	3.86	0	0	4.17	0.81	3.59
B81D	1998	7.55	13.99	34.26	20.46	11.02	16.74	6.13	3.82	2.16	5.02	0.05	0.88
B81D	1999	3.7	16.33	25.1	30.7	90.96	31.28	8.87	1.56	10.63	0.56	0.72	5.15
B81D	2000	8.43	9.07	20.15	4.85	29.78	9.16	2.78	2.67	1.3	0.72	0.32	1.74
B81D	2001	9.91	32.5	17.9	11.04	8.11	2.89	3.14	0.29	3.79	0.37	1.19	2.56

Extended Catchment Rainfall file as a % of MAP for B83B (all gauges used)

	Year	Oct	Nov	Dec	Jan	Feb	Mar	Apr	May	Jun	Jul	Aug	Sep
B83D	1920	14.17	9.6	7.83	6.02	15.11	22.4	6.28	1	0	0	0	2.18
B83D	1921	6.65	13.13	29.72	1.68	7.39	11.01	0	1.61	0	0.67	1.94	4.71
B83D	1922	7.96	16.59	8.44	56.05	32.67	16.32	4.97	0	0	0	0.57	0
B83D	1923	0	2.53	21.29	8.57	7.22	47.72	10.92	3.97	0	0	0.85	1.24
B83D	1924	5.99	20.14	14.72	34.64	18.36	48.39	5.41	7.75	0.42	0.62	0	2.89
B83D	1925	5.25	6.14	10.66	26.42	28.81	12.49	3.67	0.93	0.28	4.08	0	0.13
B83D	1926	0.03	9.59	13.64	6.96	6.31	7.17	2.84	0	0.32	10.15	2.64	0.02
B83D	1927	16.74	8.43	24.07	34.8	6.04	2.23	3.21	0	0	0.31	0.92	0.57
B83D	1928	4.6	12.46	16.97	13.39	26.33	13.87	14.96	0.06	1.12	0.55	0.69	1.17
B83D	1929	8.19	17.48	20.16	7.36	20.98	29.98	9.37	0.66	3.1	4.44	0.06	1.3
B83D	1930	0.13	8.96	53.44	7.54	10.23	15.05	12.82	0	0.09	11.39	0	1.11
B83D	1931	5.1	8.07	11.95	11	5.43	18.07	8.32	4.62	0	0	0.07	0.39
B83D	1932	3.28	5.49	35.41	37.06	2.9	6.39	0.86	0	0.4	1.48	0.58	0.42
B83D	1933	1.23	20.53	11.54	17.89	3.51	14.73	8.26	2.48	0.94	0	0.07	2.22
B83D	1934	12.29	23.29	20.12	7.94	8.58	2.86	1.05	3.74	1.04	1.43	0.11	3.09
B83D	1935	2.87	1.92	6.25	28.68	10.25	18.51	4.81	4.48	0.79	2.01	0.4	8.56
B83D	1936	4.76	11.55	14.61	15.39	33.46	9.28	1.64	0	0.06	0.6	0.25	1.8
B83D	1937	0.32	5.02	17.94	20.92	11.4	2.88	26.35	1.41	1.02	1.2	0	14.93
B83D	1938	18.67	5.84	30.87	18.21	51.59	12.47	1.61	5.09	0.71	6.75	0.33	7.19
B83D	1939	2.03	29.46	22.78	9.05	2.82	20.04	16.06	3.03	10.91	0	0.09	0.96
B83D	1940	7.34	16.99	27.43	6.32	4.16	3.22	17.62	0	0	0.15	0.07	0.61
B83D	1941	3.48	8.4	27.71	23.29	6.56	34.22	1.94	3.19	4.07	0.09	1.04	5.66
B83D	1942	6.13	10.72	8.72	3.23	8.57	19.49	23.12	0.5	0	4.56	4.63	1.01
B83D	1943	1.44	8.01	5.26	12.2	44.2	5.2	0.62	0.05	1.96	0	0.98	0
B83D	1944	9.04	8.78	6.46	20.95	9.37	2.4	9.49	0.14	0	0	0	0.77
B83D	1945	8.33	8.71	2.54	46.64	23.07	8.63	4.33	0	0	0.41	0	0
B83D	1946	0.55	9.95	9.79	8.22	13.93	9.27	3.29	0.62	1.62	0.4	0	0.09
B83D	1947	3.59	13.96	25.16	27.49	7.63	44.03	1.61	0.97	0	0	0	0.46
B83D	1948	10.88	10.74	7.65	37.46	7.68	2.23	6.04	1.64	3.06	1.83	0	0.28
B83D	1949	0.61	19.76	16.64	5.01	18.08	25.22	9.03	2.84	0.12	0.42	0.07	0.3
B83D	1950	2.42	9.58	25.45	2.58	0	10.97	10.68	5.43	0.02	0.24	4.7	2.37
B83D	1951	9.44	3.19	8.99	17.55	9.6	7.05	3.55	0.64	3.09	2.63	0.41	0.22
B83D	1952	9.41	14.29	21.33	21.28	30.92	13.47	9.13	0.62	0	0	0.35	1.4
B83D	1953	0.22	21.46	2.45	17.48	28.48	4.77	9.07	0.67	0.15	0	1.62	0.05
B83D	1954	5.34	17.25	20.04	22.98	25.54	14.67	8.93	1.23	0.79	0.32	0.26	0.09
B83D	1955	9.09	19.87	19.01	2.77	64.28	9.57	1.37	5.97	0.81	0	0.13	7.16
B83D	1956	2.71	3.57	20.07	24.14	24.07	15.04	3.47	1.9	0.6	4.93	0.97	4.6
B83D	1957	14.96	7.78	13.84	80.92	7.59	0.77	1.11	0.08	1.04	0.65	0	8.81
B83D	1958	2.98	21.63	25.94	19.84	21.96	3.76	0.88	1.12	1.49	4.37	0	5.71
B83D	1959	4.82	5.24	10.74	8.96	43.23	6.12	14.9	6.15	0.69	1.75	0.12	1.46
B83D	1960	2	15.18	27.03	10.1	22.63	11.11	6.7	0.65	6.02	1.09	1.84	6.84
B83D	1961	2.71	4.66	23.22	17.92	7.38	8.7	10.25	0.21	0.11	0.02	0.95	0.05
B83D	1962	2.82	31.19	25.27	9.35	1.95	4.15	4.85	3.23	5.85	1.36	0.11	0.18
B83D	1963	5.7	4.47	10.78	11.68	7.95	1.6	3.76	3.04	0	0	0.49	0.36
B83D	1964	13.14	10.79	28.02	15.72	9.55	1.91	2.3	0.07	0.76	0	0.29	8.28
B83D	1965	1.12	9.33	10.68	20.9	18.17	3.11	2.22	0.46	0.03	0.02	4.53	1.18
B83D	1966	7.73	4.78	10.31	27.55	24.25	6.6	14.56	0.71	0.57	1.34	0.29	0
B83D	1967	10.14	10.34	10.57	4.56	16.1	3.21	9.4	2.88	3.45	0.22	0.28	0
B83D	1968	2.56	14.39	34.22	11.76	7.81	30.58	3.99	0.53	0.08	0.16	0.02	1.53

B83D	1969	23.39	7.63	11.3	1.03	11.36	2.96	1.09	1.14	0.81	1.38	0	0.5
B83D	1970	4.44	6.67	17.52	29.34	10.02	7.54	12.59	1.46	1.47	0.22	0.11	4.21
B83D	1971	6.95	14.41	15.48	32.61	23.59	26.4	0.87	7.61	0	0.06	0.14	0.27
B83D	1972	8.6	6.38	10.38	19.77	3.73	8.24	7.56	1.38	0.12	2.18	0.26	24.43
B83D	1973	6.35	7.82	29.36	18.66	33.31	13.28	7.38	3.53	0	6.69	0.23	7.11
B83D	1974	3.64	21.22	12.29	27.88	28.59	6.63	4.24	5.85	1.41	0	0	0.11
B83D	1975	0.21	11.06	24.86	30.61	26.02	18.75	6.17	9.69	0.25	0.17	0.19	0
B83D	1976	3.85	10.16	3.62	22.64	40.6	19.56	2.78	0.73	0	0	0.52	11.42
B83D	1977	0.73	14.71	20.8	20.99	19.31	28.22	6.76	0.09	0.4	4.36	0.07	0.5
B83D	1978	7.9	15.89	17.68	12.94	8.31	8.92	5.91	2.75	0.11	0.37	7.36	0.01
B83D	1979	10.35	11.17	23.08	16.73	41.3	8.42	7.84	0.33	0	0.29	3.14	14.33
B83D	1980	10.06	18.24	25.43	42.22	17.42	21.16	2.38	4.13	0	0.11	4.04	3.22
B83D	1981	8.43	17.04	4.08	12.23	2.21	0.81	7.13	7.06	0	0.17	0.11	0.14
B83D	1982	4.62	4.6	6.64	11.05	6.56	10.86	0.44	2.11	0.7	0.32	3.47	0
B83D	1983	6.03	17.78	10.96	10.75	10.83	15.38	1.58	0.05	0.19	12.81	0.6	4.25
B83D	1984	17.84	13.95	17.5	36.62	18.33	10.23	1.05	4.95	2.05	2.28	0.1	3.19
B83D	1985	18.94	8.04	14.77	2.82	5.8	2.13	15.99	0.38	0	0	0.78	0.18
B83D	1986	4.29	8.09	17.31	17.09	6.02	10.22	1.44	0.51	1.97	0	8.01	9.41
B83D	1987	8.47	2.69	36.27	12.07	20.18	15.55	0.83	0.06	1.59	0.17	1.36	2.44
B83D	1988	13.18	1.25	19.65	6.84	22.74	6.58	1.26	0.16	2.64	0	0.54	0.05
B83D	1989	13.58	22.48	18.16	23.2	13.47	12.88	12.1	0.15	0	0.66	0.82	0
B83D	1990	6.17	11.7	23.05	21.31	11.24	13.39	0.8	1.83	1.73	0.04	0	0.97
B83D	1991	0.3	10.86	4.23	8.31	1.6	6.17	1	0.05	2.36	0	0.89	0.11
B83D	1992	1.27	12.74	29.59	14.2	8.51	7.53	4.16	0.64	0.19	1.17	0.52	0.11
B83D	1993	2.78	19.27	16.72	10.49	4.05	5.95	3.87	0.39	0.04	0.12	0.75	2.39
B83D	1994	7.62	7.1	16.55	24.47	11.21	9.88	12.06	3.33	0.09	0	1.07	0.77
B83D	1995	6.82	12.32	17.16	31.13	41.34	10.19	10.09	8.56	0.85	7.05	1.76	2.87
B83D	1996	5.75	13.75	15.6	25.47	18.87	11.59	4.79	3.36	0.04	0	0.56	7.56
B83D	1997	6.42	23.08	6.99	19.1	2.51	3.98	2.57	0.07	0	1.77	0.83	3.26
B83D	1998	10.63	17.07	34.74	25.7	23.85	13.93	7.06	1.83	0.31	3.06	0.3	1.64
B83D	1999	5.23	18.43	18.39	32.34	81.84	29.3	7.07	2.51	2.37	1.05	0	2.65
B83D	2000	6.49	9.28	10.15	12.1	37.35	18.59	9.23	0.71	4.08	0.04	0	0
B83D	2001	8.28	25.37	8.9	10.02	0.75	3.45	3.58	0	2.87	0	0.04	2.12

Appendix B
WRSM2000: Input Data

WRSM2000 Network diagram of Letsitele Catchment

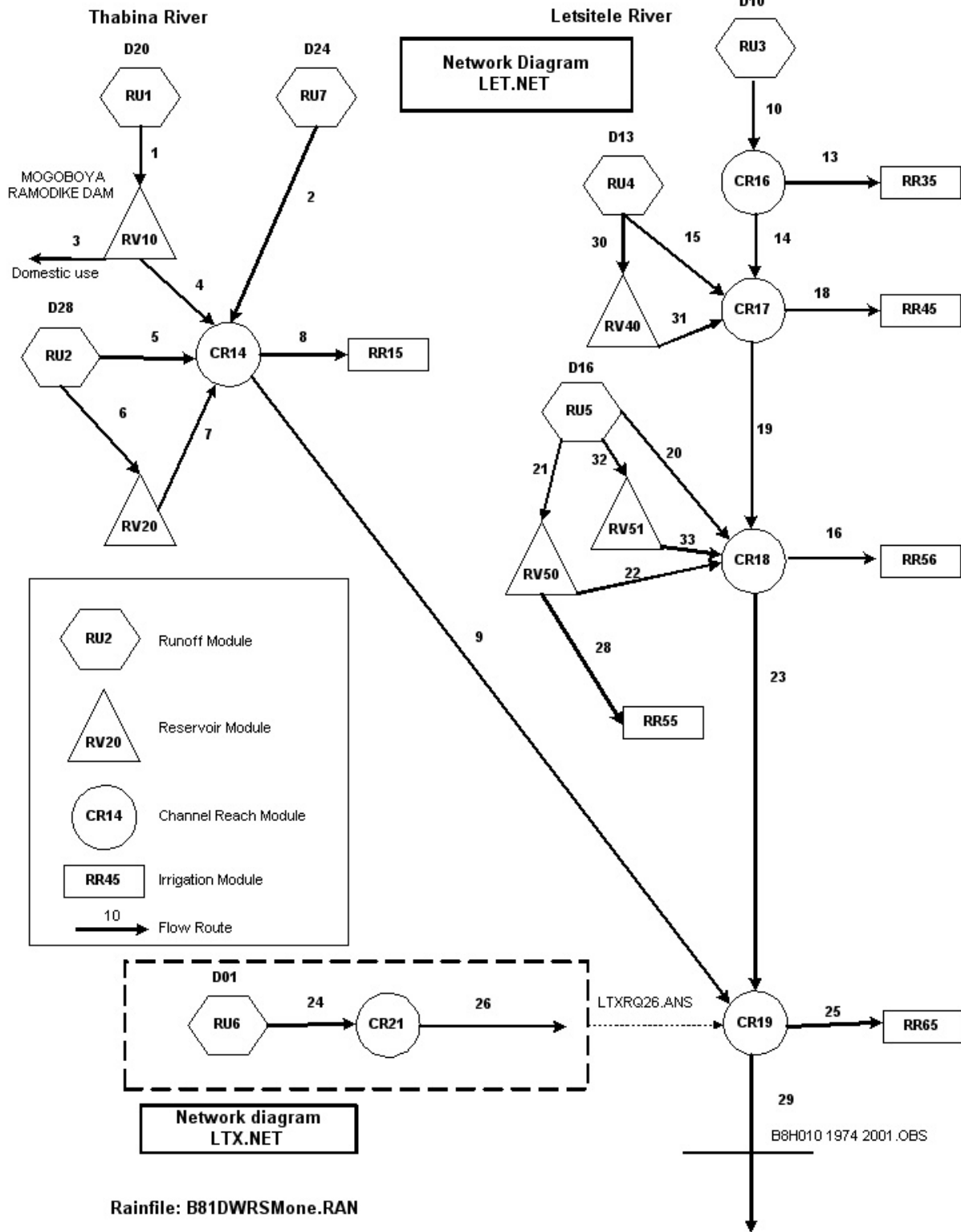

Present Day Development

WRSM2000 Network diagram of Letsitele Catchment

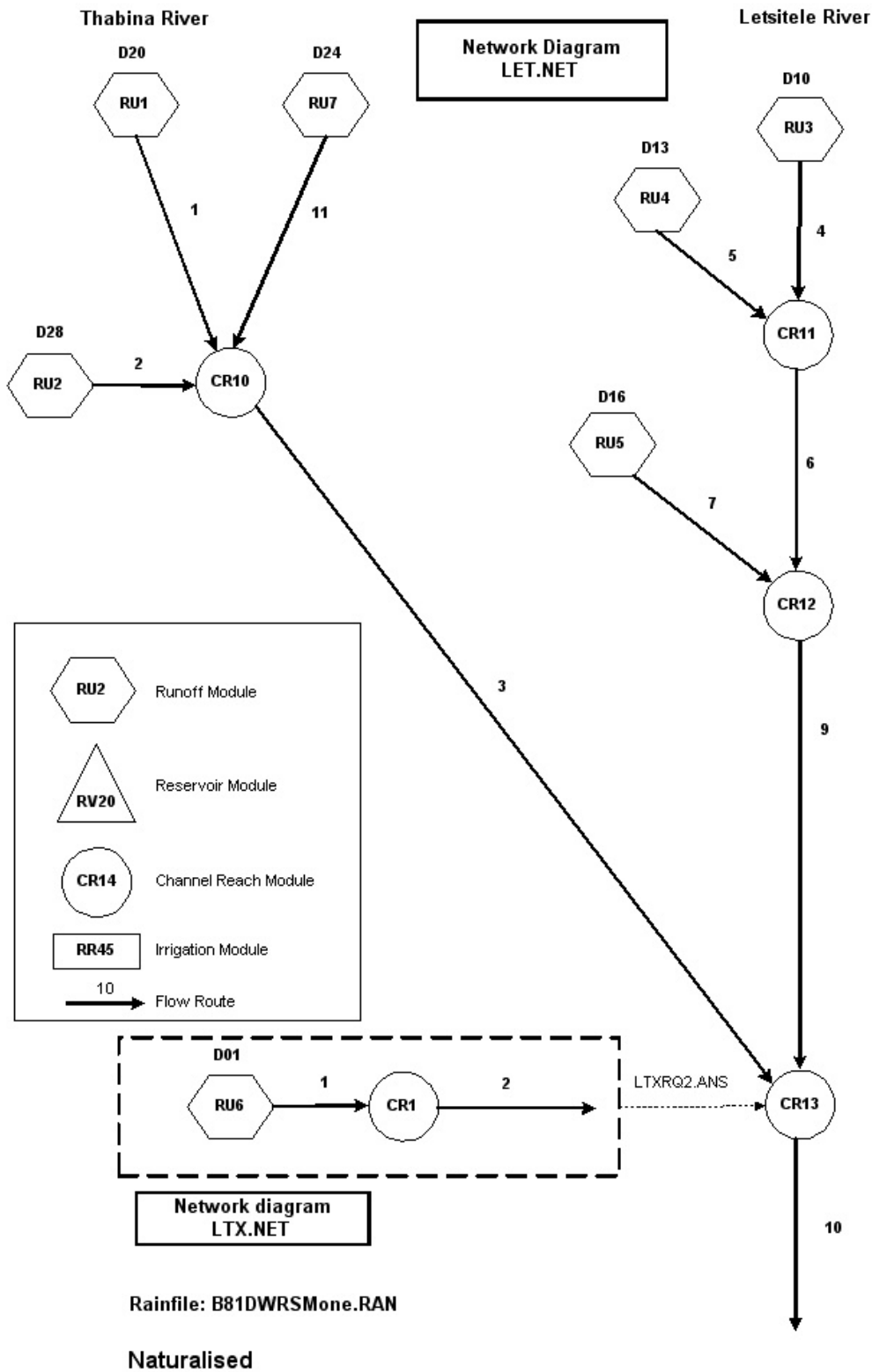

WRSM2000 Network diagram of Tsende Catchment

Network Diagram
LET.NET

Tsende River (B83B)

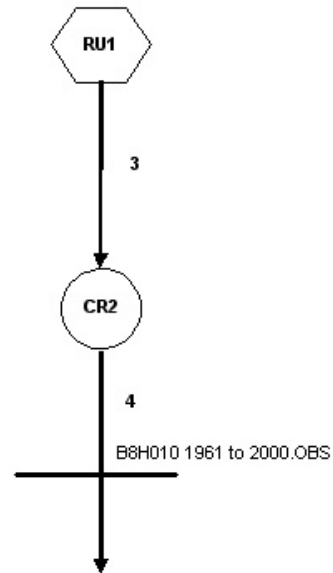
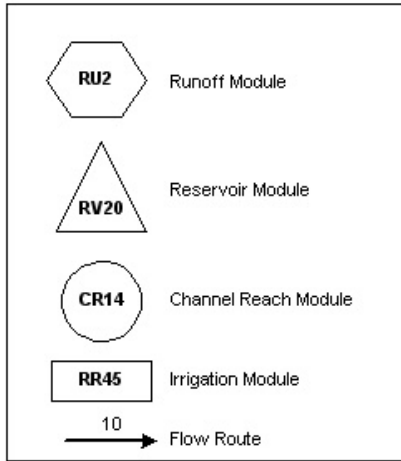

Rainfile: B83BWRSM2000.RAN

Streamflow Gauge B8H010 (units – million cubic meters)

Year	Oct	Nov	Dec	Jan	Feb	Mar	Apr	May	Jun	Jul	Aug	
1974	0.85	3.038	8.496	7.415	22.204	11.542	7.181	4.009	2.812	1.758	1.135	0.868
1975	0.4	0.3	10.217	18.249	30.300*	65.929	26.02	12.934	6.827	4.603	3.291	1.991
1976	1.712	4.334	1.132	2.934	25.26	26.573	9.689	4.699	2.617	1.551	1.309	1.529
1977	1.432	1.938	2.054	48.612	21.099	32.608	8.934	4.604	3.253	2.871	1.774	1.115
1978	1.63	2.836	2.87	1.75	1.519	6.118	1.148	1.183	0.537	0.403	0.715	0.734
1979	1.365	1.988	5.554	9.576	29.691	14.992	5.161	2.148	1.341	0.977	1.079	1.257
1980	1.264	9.007	15.177	39.679	64.079	25.516	10.215	6.197	3.937	2.899	2.381	2.259
1981	2.396	2.042	3.697	4.105	1.723	0.775	0.498	1.034	0.304	0.227	0.163	0.078
1982	0.088	0.215	0.213	1.369	0	1.837	0.175	0.028	0.066	0.073	0.011	0
1983	0.012	1.79	1.251	0.265	0	1.358	0.942	0	0	0.026	0.028	0.763
1984	0.83	5.49	4.659	5.173	27.474	7.636	1.835	1.25	1.237	0.881	0.32	1.446
1985	0.219	0.624	0.592	0.728	0.728	1.382	3.436	1.29	0.289	0.079	0.038	0.025
1986	0.019	0.442	7.386	3.855	2.025	3.5	1.098	0.179	0.019	0	0.009	0.176
1987	1.143	0.354	16.362	7.51	20.044	45.035	6.784	2.923	1.703	2.376	0.931	1.171
1988	3.479	1.659	3.84	2.621	9.563	6.707	0.866	0.629	0.989	0.435	0.469	0.028
1989	0.817	2.438	8.196	6.317	11.517	5.997	7.33	2.223	1	0.847	0.699	0.327
1990	0.332	0.349	4.797	15.557	8.847	9.534	4.893	2.275	2.3	1.052	0.45	0.267
1991	0.105	0.14	0.028	0.12	0.14	0.138	0.016	0.014	0.058	0.143	0.022	0
1992	0.026	0.132	3.898	0.628	0.007	1.898	0.011	0.008	0	0.001	0.054	0.015
1993	0	0.16	3.16	1.65	4.49	1.29	0.11	0.01	0.01	0.01	0.01	0
1994	0	0	0	2.5	0.35	0.73	0.66	0.19	0.01	0	0.01	0
1995	0	9.13	11.05	14.44	92.49	33.43	9.63	10.28	4.19	3.4	3.46	1.51
1996	1.24	1.96	3.10+	14.72+	9.37	44.72+	10.91+	5.10+	3.08+	2.27	1.34	1.91
1997	1.3	1.45+	2.17+	7.63	5.31	2.47	1.31	0.29	0.08	0.17	0.24	0.1
1998	0.74	3.25	10.67	7.04	6.85	23.45	10.23	5.89	3.82	3.42	2.02	1.14
1999	1.23	2.35	32.05	28.94	202.66	101.72	53.27	21.81	14.49	9.36	6.24	4.17
2000	3.23	5.08	10.09	4.3	15.98	19	7.96	5.82	4.04	3.3	2.55	2.08
2001	1.53	9.4	14.17	6.65	9	4.15	1.82+	0+	0+	0+	0+	0+

Streamflow Gauge B8H011 (units – million cubic meters)

Year	Oct	Nov	Dec	Jan	Feb	Mar	Apr	May	Jun	Jul	Aug
1961	0	0	0.13	0	0	0	0	0	0	0	0
1962	0	1.89	0.02	0	0	0	0	0	0	0	0
1963	0	0	0	0	0	0	0	0	0	0	0
1964	0	0	0	0.92+	0.01#	0	0	0	0	0	0
1965	0	0	0.09	0	0	0	0	0	0	0	0
1966	0	0	0	0.99#	0.86#	0.18#	0.02#	0.01#	0	0	0
1967	0	0	0#	0#	0	0	0	0	0	0	0
1968	0	0	2	0	0	0.4	0	0	0	0	0
1969	0	0	0	0	0	0	0	0	0	0	0
1970	0	0	0	0	0.02	0	0	0	0	0	0
1971	0	0	0	0.08	2.26	0	0	0	0	0	0
1972	0	0	0.05	0.22	0.06#	0#	0#	0#	0#	0#	0.55#
1973	0.18#	0.00#	1.33#	0.56#	2.37#	0.78#	0.00#	0.00#	0.00#	0.00#	0.00#
1974	0.00#	0.26#	0.09#	1.05#	1.53#	0.39#	0.00#	0.00#	0.00#	0.00#	0.00#
1975	0.00#	0.00#	0.60#	1.81#	1.29#	0.37#	0.04#	0.00#	0.00#	0.00#	0.00#
1976	0.00#	0.00#	0.00#	0.37#	5.42#	1.92#	0.05#	0.00#	0.00#	0.00#	0.00#
1977	0.00#	0.02#	0.23#	0.32#	0.23#	1.16#	0.37#	0.00#	0.00#	0.00#	0.00#
1978	0.00#	0.04#	0.09#	0.03#	0.00#	0.00#	0.00#	0.00#	0.00#	0.00#	0.00#
1979	0.00#	0.00#	0.41#	0.19#	5.68#	1.89#	0.00#	0.00#	0.00#	0.00#	0.01#
1980	0#	0.10#	0.71#	6.40#	3.97	1.22	0.14	0.01	0	0	0#
1981	0	0	0	0	0	0	0	0	0	0	0
1982	0	0	0	0	0	0	0	0	0.01	0#	0#
1983	0#	0	0	0.01+	0.62	0.02	0.01	0	0	0	0
1984	0	0	0	12.10+	1.12	0.01	0	0.01	0.02	0.02	0.02
1985	0.05	0.01	0	0	0	0	0	0	0	0	0
1986	0	0	0	0.01	0	0	0	0	0	0	0
1987	0	0	0.03	0.02	2.23+	0.44	0	0	0	0	0
1988	0	0	0	0	0	0	0	0	0	0	0
1989	0	0.02	0.04	0.02	0.02	0.02	0.01	0.01	0.01	0.01	0.01
1990	0	0.01	0.01	0	0	0	0	0	0	0	0
1991	0	0	0	0	0	0	0	0	0	0	0
1992	0	0	0.09	0.6	1.2	0.2	0.09	0.07	0.07	0.07	0.01
1993	0	0	0.02	0	0	0	0	0	0	0	0
1994	0	0	0.01	0	0	0	0	0	0	0	0
1995	0	0	0	0.94	5.38	0.05	0.01	0.02	0.02	0	0
1996	0	0.01	0.02	0	0	0	0	0	0	0#	0#
1997	0	0	0	0	0	0	0	0	0	0	0
1998	0	0.01	0.01	1.11	10.60+	0.02	0.01	0	0	0	0
1999	0	0	0	2.23	55.17#	3.79	0.53	0.41	0.01	0.06	0.11
2000	0.02	0.14	0.02	0.01	0.2	1.17	0.1	0.04	0.02	0.01	0#

Appendix C

WRSM2000: Output information

WRSM 2000 : Results for System LET
 =====

DATE: 2004/09/23

Calibration Parameters

- POW - Power of soil moisture/subsurface flow eqn.
- SL - Soil moisture state when subsurface flow=0
- ST - Soil moisture capacity in mm
- FT - Subsurface flow at soil moisture capacity
- GW - Maximum groundwater flow in mm/month
- ZMIN - Minimum catchment absorption in mm/month
- ZMAX - Maximum catchment absorption in mm/month
- PI - Interception storage in mm
- TL - Lag of flow (excluding groundwater)
- GL - Lag of groundwater flow in months
- R - Coeff. in evaporation/soil moisture eqn.

Module	POW	SL	ST	FT	GW	ZMIN	ZMAX	PI	TL	GL	R
1	2.00	0.00	750.00	56.00	0.00	50.00	1100.00	1.50	0.40	0.00	0.50
7	2.00	0.00	750.00	42.00	0.00	50.00	1100.00	1.50	0.40	0.00	0.50
2	0.00	0.00	250.00	0.00	0.00	100.00	800.00	1.50	0.25	0.00	0.50
3	2.00	0.00	750.00	67.00	0.00	50.00	1100.00	1.50	0.40	0.00	0.50
4	2.00	0.00	750.00	40.00	0.00	50.00	1100.00	1.50	0.40	0.00	0.50
5	2.00	0.00	600.00	15.00	0.00	50.00	1000.00	1.50	0.25	0.00	0.50

WRSM 2000 : Results for System LET
 =====

FLOW STATISTICS : ROUTE NO. 29

Observations file:C:\LETABA\WRSM2000\B81D\PD_NEWRAIN\B8H010 1974 2001.OBS

INDEX	UNITS	OBSERVED	SIMULATED
MEAN ANNUAL RUNOFF (M A R)	M**3*10**6	75.72	75.86
STANDARD DEVIATION OF ANNUAL FLOWS (S)	M**3*10**6	96.98	100.77
COEFFICIENT OF VARIABILITY (S/MAR)	PERCENT	128.08	132.83
COEFF. OF SKEWNESS	-	2.8956	3.0994
RANGE	PERCENT MAR	880.84	823.90
AUTOCORRELATION COEFF OF ANNUAL FLOWS	-	0.0741	0.0078
MEAN OF LOGS OF ANNUAL FLOWS	(M**3*10**6)	1.5522	1.5493
STD. DEV. OF LOGS OF ANNUAL FLOWS	-	0.6209	0.6543
INDEX OF SEASONAL VARIABILITY	PERCENT	41.63	43.59

SIMULATED MONTHLY FLOWS : ROUTE NO. 29

YEAR	OCT	NOV	DEC	JAN	FEB	MAR	APR	MAY	JUN	JUL	AUG	SEP	TOTAL
1974 (OBS. =	1.65 0.85	2.92 3.04	3.09 8.50	8.58 7.41	17.76 22.20	11.46 11.54	8.05 7.18	6.21 4.01	4.54 2.81	2.90 1.76	1.55 1.13	0.63 0.87	69.32 (71.31)
1975 (OBS. =	0.35 0.40	0.14 0.30	13.57 10.22	39.76 18.25	34.32 30.30*	60.23 65.93	28.33 26.02	9.62 12.93	6.75 6.83	4.72 4.60	2.77 3.29	1.43 1.99	201.98 (181.06)
1976 (OBS. =	1.29 1.71	2.06 4.33	0.00 1.13	9.75 2.93	9.62 25.26	21.85 26.57	13.33 9.69	6.98 4.70	4.82 2.62	3.06 1.55	1.77 1.31	1.97 1.53	76.51 (83.34)
1977 (OBS. =	1.11 1.43	1.21 1.94	2.17 2.05	34.44 48.61	25.41 21.10	16.68 32.61	10.72 8.93	6.37 4.60	4.30 3.25	2.83 2.87	1.40 1.77	0.71 1.12	107.35 (130.29)
1978 (OBS. =	0.70 1.63	1.78 2.84	0.14 2.87	2.71 1.75	2.03 1.52	3.01 6.12	3.28 1.15	2.80 1.18	1.86 0.54	1.11 0.40	1.39 0.71	0.46 0.73	21.27 (21.44)
1979 (OBS. =	1.30 1.37	1.43 1.99	2.57 5.55	5.77 9.58	32.05 29.69	16.82 14.99	7.22 5.16	4.87 2.15	3.28 1.34	2.13 0.98	1.18 1.08	1.34 1.26	79.97 (75.13)
1980 (OBS. =	1.39 1.26	5.56 9.01	5.44 15.18	50.18 39.68	57.48 64.08	25.55 25.52	10.13 10.22	6.82 6.20	4.63 3.94	2.96 2.90	1.91 2.38	1.08 2.26	173.12 (182.61)
1981 (OBS. =	1.53 2.40	2.26 2.04	0.75 3.70	2.90 4.11	1.26 1.72	0.97 0.77	1.61 0.50	1.55 1.03	0.81 0.30	0.45 0.23	0.00 0.16	0.00 0.08	14.09 (17.04)
1982 (OBS. =	0.00 0.09	0.04 0.22	0.00 0.21	0.12 1.37	0.00 0.00	0.73 1.84	0.49 0.17	0.32 0.03	0.22 0.07	0.00 0.07	0.00 0.01	0.00 0.00	1.93 (4.08)
1983 (OBS. =	0.00 0.01	0.43 1.79	0.00 1.25	0.02 0.26	0.22 0.00	2.42 1.36	2.04 0.94	1.26 0.00	0.88 0.00	1.67 0.03	0.42 0.03	0.38 0.76	9.74 (6.43)
1984 (OBS. =	1.57 0.83	4.45 5.49	1.17 4.66	4.35 5.17	12.59 27.47	8.86 7.64	5.28 1.84	4.77 1.25	3.80 1.24	2.66 0.88	1.35 0.32	1.64 1.45	52.50 (58.23)
1985 (OBS. =	1.91 0.22	0.82 0.62	0.28 0.59	1.32 0.73	1.67 0.73	1.51 1.38	5.39 3.44	3.93 1.29	2.71 0.29	1.56 0.08	0.75 0.04	0.13 0.03	21.98 (9.43)
1986 (OBS. =	0.53 0.02	1.19 0.44	1.81 7.39	2.78 3.86	3.98 2.03	3.60 3.50	3.65 1.10	2.75 0.18	2.21 0.02	1.13 0.00	0.61 0.01	1.61 0.18	25.85 (18.71)
1987 (OBS. =	1.31 1.14	1.21 0.35	8.06 16.36	6.20 7.51	24.93 20.04	50.02 45.03	23.00 6.78	6.64 2.92	5.09 1.70	3.27 2.38	2.09 0.93	1.66 1.17	133.47 (106.34)
1988 (OBS. =	3.73 3.48	1.87 1.66	0.68 3.84	1.55 2.62	4.70 9.56	3.20 6.71	3.16 0.87	2.15 0.63	1.98 0.99	0.93 0.44	0.29 0.47	0.00 0.03	24.23 (31.28)
1989 (OBS. =	0.53 0.82	1.58 2.44	2.21 8.20	6.94 6.32	7.80 11.52	6.79 6.00	6.52 7.33	4.83 2.22	3.43 1.00	2.25 0.85	1.03 0.70	0.23 0.33	44.13 (47.71)
1990 (OBS. =	0.69 0.33	0.62 0.35	1.88 4.80	9.44 15.56	8.01 8.85	13.52 9.53	8.52 4.89	5.08 2.28	3.87 2.30	2.32 1.05	1.10 0.45	0.51 0.27	55.57 (50.65)
1991 (OBS. =	0.05 0.10	0.26 0.14	0.00 0.03	0.00 0.12	0.00 0.14	0.00 0.14	0.00 0.02	0.00 0.01	0.00 0.06	0.00 0.14	0.00 0.02	0.00 0.00	0.31 (0.92)
1992 (OBS. =	0.00 0.03	0.00 0.13	0.73 3.90	0.29 0.63	0.33 0.01	2.42 1.90	1.72 0.01	1.21 0.01	0.81 0.00	0.35 0.00	0.00 0.05	0.00 0.01	7.86 (6.68)
1993 (OBS. =	0.00 0.00	0.78 0.16	1.04 3.16	0.63 1.65	3.00 4.49	2.08 1.29	2.52 0.11	1.66 0.01	1.14 0.01	0.49 0.01	0.00 0.01	0.00 0.00	13.33 (10.90)
1994 (OBS. =	0.00 0.00	0.00 0.00	0.00 0.00	0.78 2.50	2.22 0.35	1.97 0.73	2.84 0.66	2.08 0.19	1.46 0.01	0.75 0.00	0.02 0.01	0.00 0.00	12.12 (4.45)
1995 (OBS. =	0.00 0.00	1.61 9.13	1.36 11.05	7.87 14.44	88.18 92.49	41.83 33.43	9.37 9.63	7.66 10.28	5.77 4.19	5.23 3.40	3.70 3.46	2.23 1.51	174.83 (193.01)
1996 (OBS. =	2.16 1.24	2.15 1.96	7.11 3.10+	22.37 14.72+	16.65 9.37	28.68 44.72+	16.28 10.91+	6.91 5.10+	4.62 3.08+	3.01 2.27	1.48 1.34	1.48 1.91	112.91 (99.72)
1997 (OBS. =	1.67 1.30	1.53 1.45+	0.22 2.17+	4.63 7.63	2.92 5.31	1.86 2.47	2.18 1.31	1.20 0.29	0.75 0.08	0.74 0.17	0.00 0.24	0.00 0.10	17.71 (22.52)
1998 (OBS. =	0.25 0.74	1.11 3.25	17.01 10.67	15.23 7.04	7.71 6.85	8.16 23.45	7.48 10.23	6.07 5.89	4.65 3.82	3.90 3.42	2.12 2.02	1.15 1.14	74.84 (78.52)
1999 (OBS. =	0.86 1.23	2.36 2.35	6.51 32.05	23.87 28.94	240.87 202.66	164.52 101.72	37.06 53.27	8.63 21.81	7.67 14.49	5.26 9.36	3.53 6.24	2.72 4.17	503.85 (478.29)
2000 (OBS. =	2.71 3.23	2.18 5.08	3.86 10.09	2.81 4.30	13.38 15.98	8.67 19.00	5.38 7.96	4.11 5.82	2.94 4.04	1.85 3.30	0.74 2.55	0.21 2.08	48.85 (83.43)
2001 (OBS. =	1.07 1.53	13.23 9.40	9.05 14.17	5.88 6.65	4.64 9.00	3.08 4.15	3.00 1.82+	1.82 0.00+	1.75 0.00+	0.77 0.00+	0.14 0.00+	0.00 0.00+	44.43 (46.72)
% TOTAL (OBS. =	1.34 1.29	2.58 3.39	4.27 8.81	12.77 12.47	29.37 29.37	24.03 23.58	10.76 9.06	5.57 4.58	4.08 2.78	2.74 2.03	1.48 1.45	1.01 1.18	100.00 (100.00)

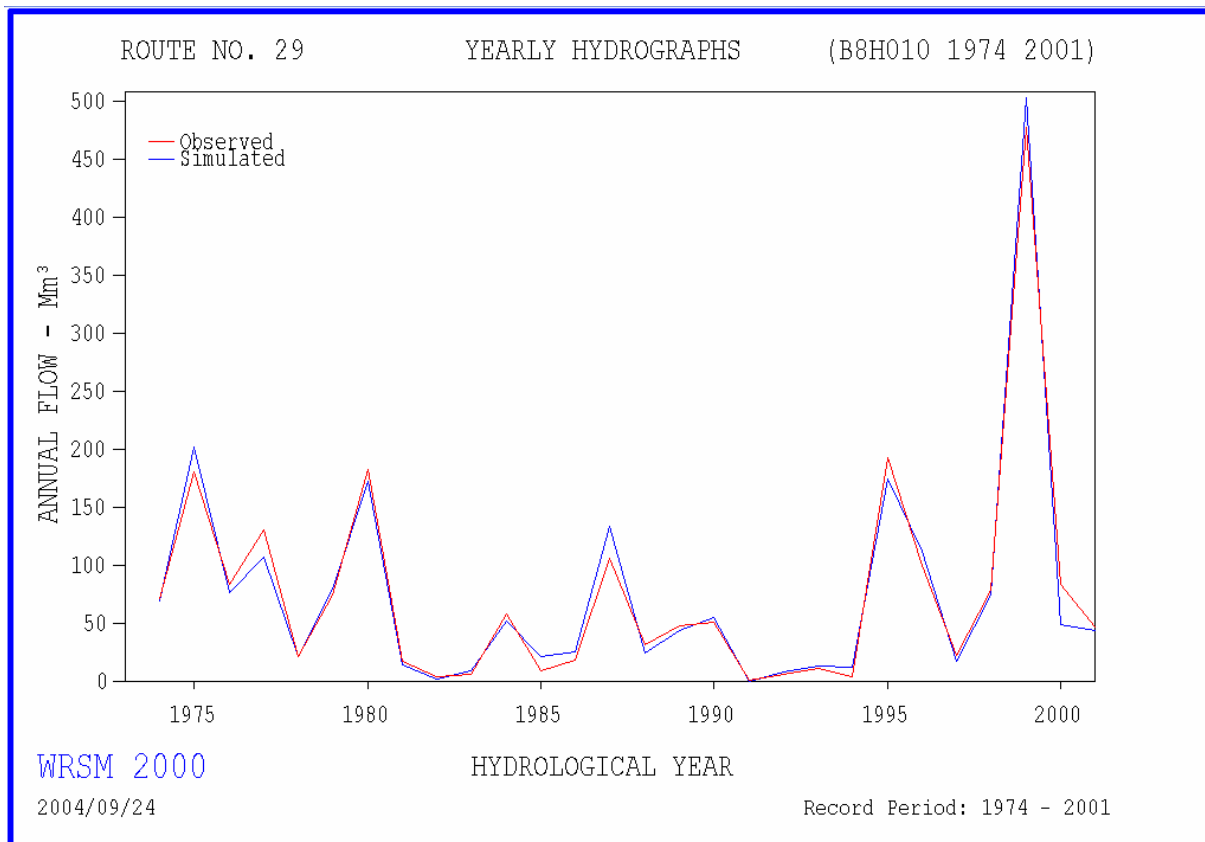
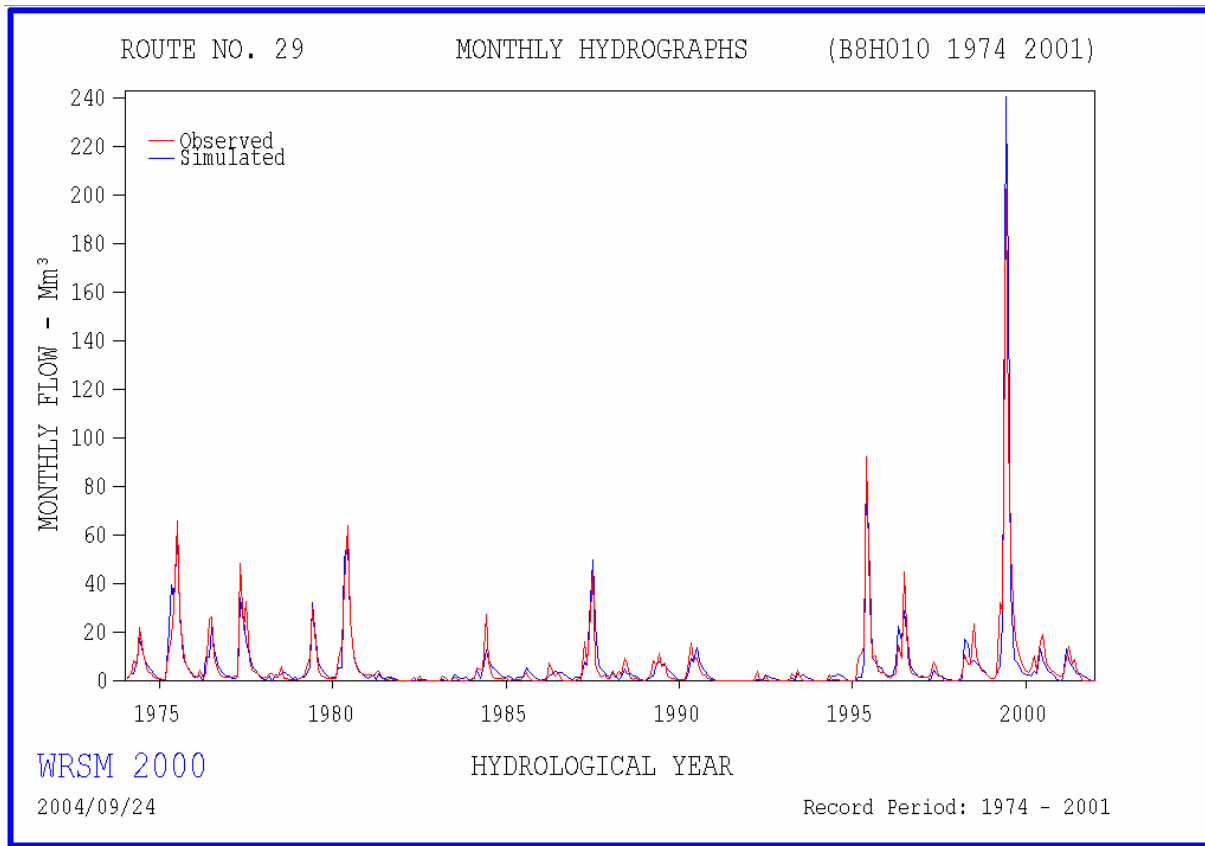

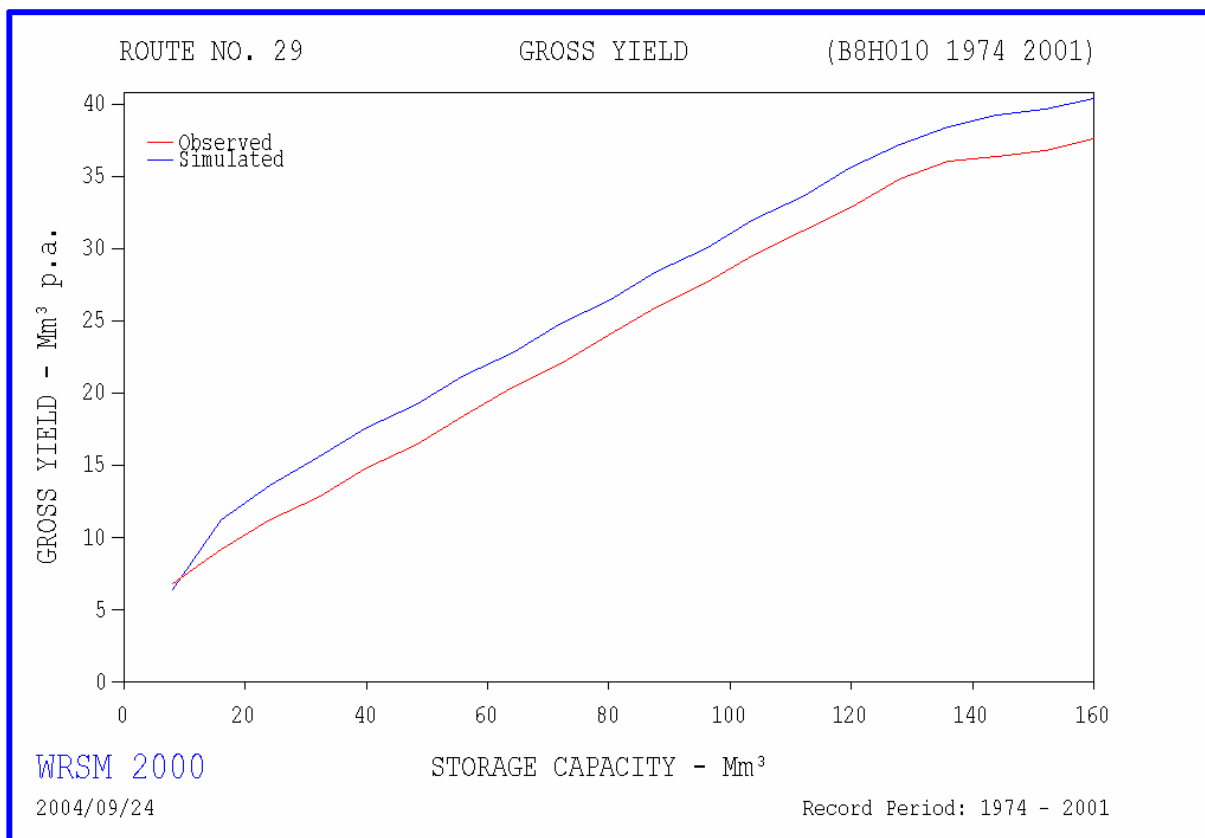
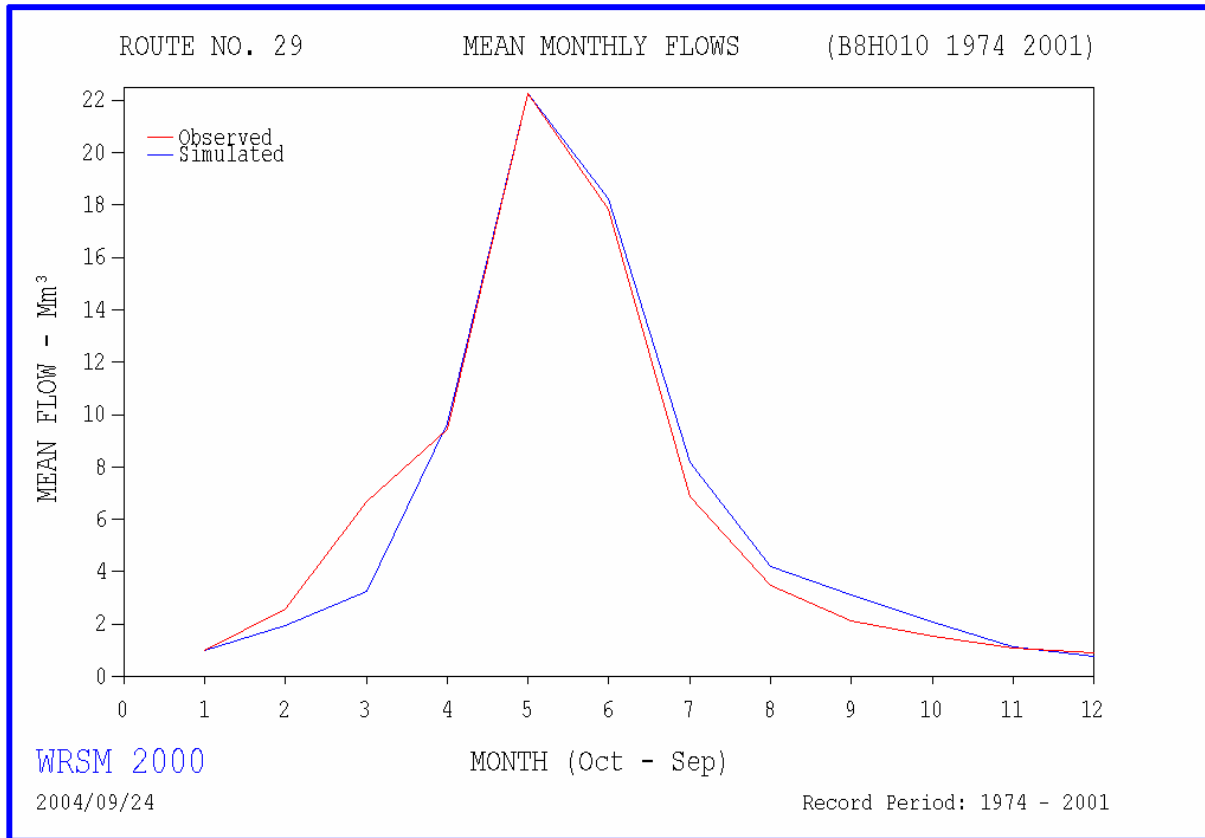

WRSM 2000 : Results for System LET
 =====

DATE: 2004/09/23

Calibration Parameters

- POW - Power of soil moisture/subsurface flow eqn.
- SL - Soil moisture state when subsurface flow=0
- ST - Soil moisture capacity in mm
- FT - Subsurface flow at soil moisture capacity
- GW - Maximum groundwater flow in mm/month
- ZMIN - Minimum catchment absorption in mm/month
- ZMAX - Maximum catchment absorption in mm/month
- PI - Interception storage in mm
- TL - Lag of flow (excluding groundwater)
- GL - Lag of groundwater flow in months
- R - Coeff. in evaporation/soil moisture eqn.

Module	POW	SL	ST	FT	GW	ZMIN	ZMAX	PI	TL	GL	R
1	0.00	0.00	625.00	0.00	0.00	150.00	800.00	1.50	0.25	0.00	0.00

WRSM 2000 : Results for System LET
 =====

FLOW STATISTICS : ROUTE NO. 4

Observations file:C:\LETABA\WRSM2000\B83B\CALIB_ESL\B8H011P.OBS

INDEX	UNITS	OBSERVED	SIMULATED
MEAN ANNUAL RUNOFF (M A R)	M**3*10**6	3.90	3.80
STANDARD DEVIATION OF ANNUAL FLOWS (S)	M**3*10**6	10.15	12.77
COEFFICIENT OF VARIABILITY (S/MAR)	PERCENT	260.10	336.49
COEFF. OF SKEWNESS	-	5.1756	5.9891
RANGE	PERCENT MAR	1486.04	2081.15
AUTOCORRELATION COEFF OF ANNUAL FLOWS	-	0.1061	0.0275
MEAN OF LOGS OF ANNUAL FLOWS	(M**3*10**6)	-0.4816	-0.4156
STD. DEV. OF LOGS OF ANNUAL FLOWS	-	1.2149	1.1643
INDEX OF SEASONAL VARIABILITY	PERCENT	67.40	65.41

SIMULATED MONTHLY FLOWS : ROUTE NO. 4

YEAR	OCT	NOV	DEC	JAN	FEB	MAR	APR	MAY	JUN	JUL	AUG	SEP	TOTAL
1961	0.00	0.00	0.16	0.06	0.00	0.00	0.00	0.00	0.00	0.00	0.00	0.00	0.22
(OBS. =	0.00	0.00	0.13	0.00	0.00	0.00	0.00	0.00	0.00	0.00	0.00	0.00	0.13)
1962	0.00	1.21	0.71	0.10	0.00	0.00	0.00	0.00	0.00	0.00	0.00	0.00	2.02
(OBS. =	0.00	1.89	0.02	0.00	0.00	0.00	0.00	0.00	0.00	0.00	0.00	0.00	1.91)
1963	0.00	0.00	0.00	0.00	0.00	0.00	0.00	0.00	0.00	0.00	0.00	0.00	0.00
(OBS. =	0.00	0.00	0.00	0.00	0.00	0.00	0.00	0.00	0.00	0.00	0.00	0.00	0.00)
1964	0.00	0.00	0.63	0.21	0.00	0.00	0.00	0.00	0.00	0.00	0.00	0.00	0.84
(OBS. =	0.00	0.00	0.00	0.92+	0.01#	0.00	0.00	0.00	0.00	0.00	0.00	0.00	0.93)
1965	0.00	0.00	0.00	0.06	0.03	0.00	0.00	0.00	0.00	0.00	0.00	0.00	0.09
(OBS. =	0.00	0.00	0.09	0.00	0.00	0.00	0.00	0.00	0.00	0.00	0.00	0.00	0.09)
1966	0.00	0.00	0.00	0.56	0.41	0.08	0.00	0.00	0.00	0.00	0.00	0.00	1.05
(OBS. =	0.00	0.00	0.00	0.99#	0.86#	0.18#	0.02#	0.01#	0.00	0.00	0.00	0.00	2.06)
1967	0.00	0.00	0.00	0.00	0.00	0.00	0.00	0.00	0.00	0.00	0.00	0.00	0.00
(OBS. =	0.00	0.00	0.00#	0.00#	0.00	0.00	0.00	0.00	0.00	0.00	0.00	0.00	0.00)
1968	0.00	0.00	2.02	0.67	0.00	1.08	0.36	0.00	0.00	0.00	0.00	0.00	4.13
(OBS. =	0.00	0.00	2.00	0.00	0.00	0.40	0.00	0.00	0.00	0.00	0.00	0.00	2.40)
1969	0.17	0.06	0.00	0.00	0.00	0.00	0.00	0.00	0.00	0.00	0.00	0.00	0.23
(OBS. =	0.00	0.00	0.00	0.00	0.00	0.00	0.00	0.00	0.00	0.00	0.00	0.00	0.00)
1970	0.00	0.00	0.00	0.84	0.28	0.00	0.00	0.00	0.00	0.00	0.00	0.00	1.13
(OBS. =	0.00	0.00	0.00	0.00	0.02	0.00	0.00	0.00	0.00	0.00	0.00	0.00	0.02)
1971	0.00	0.00	0.00	1.56	0.70	0.48	0.14	0.00	0.00	0.00	0.00	0.00	2.88
(OBS. =	0.00	0.00	0.00	0.08	2.26	0.00	0.00	0.00	0.00	0.00	0.00	0.00	2.34)
1972	0.00	0.00	0.00	0.03	0.01	0.00	0.00	0.00	0.00	0.00	0.00	0.24	0.28
(OBS. =	0.00	0.00	0.05	0.22	0.06#	0.00#	0.00#	0.00#	0.00#	0.00#	0.00#	0.55#	0.88)
1973	0.08	0.00	0.84	0.30	1.75	0.58	0.00	0.00	0.00	0.00	0.00	0.00	3.56
(OBS. =	0.18#	0.00#	1.33#	0.56#	2.37#	0.78#	0.00#	0.00#	0.00#	0.00#	0.00#	0.00#	5.22)
1974	0.00	0.07	0.02	0.61	0.92	0.24	0.00	0.00	0.00	0.00	0.00	0.00	1.86
(OBS. =	0.00#	0.26#	0.09#	1.05#	1.53#	0.39#	0.00#	0.00#	0.00#	0.00#	0.00#	0.00#	3.32)
1975	0.00	0.00	0.27	1.18	0.74	0.14	0.01	0.00	0.00	0.00	0.00	0.00	2.34
(OBS. =	0.00#	0.00#	0.60#	1.81#	1.29#	0.37#	0.04#	0.00#	0.00#	0.00#	0.00#	0.00#	4.11)
1976	0.00	0.00	0.00	0.13	4.81	1.62	0.01	0.00	0.00	0.00	0.00	0.00	6.56
(OBS. =	0.00#	0.00#	0.00#	0.37#	5.42#	1.92#	0.05#	0.00#	0.00#	0.00#	0.00#	0.00#	7.76)
1977	0.00	0.00	0.06	0.08	0.04	0.67	0.22	0.00	0.00	0.00	0.00	0.00	1.07
(OBS. =	0.00#	0.02#	0.23#	0.32#	0.23#	1.16#	0.37#	0.00#	0.00#	0.00#	0.00#	0.00#	2.33)
1978	0.00	0.00	0.01	0.00	0.00	0.00	0.00	0.00	0.00	0.00	0.00	0.00	0.01
(OBS. =	0.00#	0.04#	0.09#	0.03#	0.00#	0.00#	0.00#	0.00#	0.00#	0.00#	0.00#	0.00#	0.16)
1979	0.00	0.00	0.15	0.05	5.16	1.72	0.00	0.00	0.00	0.00	0.00	0.00	7.09
(OBS. =	0.00#	0.00#	0.41#	0.19#	5.68#	1.89#	0.00#	0.00#	0.00#	0.00#	0.00#	0.01#	8.18)
1980	0.00	0.01	0.33	5.83	1.91	0.07	0.02	0.00	0.00	0.00	0.00	0.00	8.17
(OBS. =	0.00#	0.10#	0.71#	6.40#	3.97	1.22	0.14	0.01	0.00	0.00	0.00	0.00#	12.55)
1981	0.00	0.00	0.00	0.00	0.00	0.00	0.00	0.00	0.00	0.00	0.00	0.00	0.00
(OBS. =	0.00	0.00	0.00	0.00	0.00	0.00	0.00	0.00	0.00	0.00	0.00	0.00	0.00)
1982	0.00	0.00	0.00	0.00	0.00	0.00	0.00	0.00	0.00	0.00	0.00	0.00	0.00
(OBS. =	0.00	0.00	0.00	0.00	0.00	0.00	0.00	0.00	0.00	0.01	0.00#	0.00#	0.01)
1983	0.00	0.01	0.00	0.00	0.00	0.00	0.00	0.00	0.00	0.00	0.00	0.00	0.01
(OBS. =	0.00#	0.00	0.00	0.01+	0.62	0.02	0.01	0.00	0.00	0.00	0.00	0.00	0.66)
1984	0.01	0.00	0.00	2.88	0.97	0.00	0.00	0.00	0.00	0.00	0.00	0.00	3.86
(OBS. =	0.00	0.00	0.00	12.10+	1.12	0.01	0.00	0.01	0.02	0.02	0.02	0.03	13.33)
1985	0.02	0.01	0.00	0.00	0.00	0.00	0.00	0.00	0.00	0.00	0.00	0.00	0.02
(OBS. =	0.05	0.01	0.00	0.00	0.00	0.00	0.00	0.00	0.00	0.00	0.00	0.00	0.06)
1986	0.00	0.00	0.00	0.00	0.00	0.00	0.00	0.00	0.00	0.00	0.00	0.00	0.01
(OBS. =	0.00	0.00	0.00	0.01	0.00	0.00	0.00	0.00	0.00	0.00	0.00	0.00	0.01)
1987	0.00	0.00	2.74	0.91	0.04	0.01	0.00	0.00	0.00	0.00	0.00	0.00	3.70
(OBS. =	0.00	0.00	0.03	0.02	2.23+	0.44	0.00	0.00	0.00	0.00	0.00	0.00	2.72)
1988	0.00	0.00	0.03	0.01	0.13	0.04	0.00	0.00	0.00	0.00	0.00	0.00	0.22
(OBS. =	0.00	0.00	0.00	0.00	0.00	0.00	0.00	0.00	0.00	0.00	0.00	0.00	0.00)
1989	0.00	0.12	0.05	0.16	0.05	0.00	0.00	0.00	0.00	0.00	0.00	0.00	0.38
(OBS. =	0.00	0.02	0.04	0.02	0.02	0.02	0.01	0.01	0.01	0.01	0.01	0.01	0.18)
1990	0.00	0.00	0.15	0.12	0.02	0.00	0.00	0.00	0.00	0.00	0.00	0.00	0.30
(OBS. =	0.00	0.01	0.01	0.00	0.00	0.00	0.00	0.00	0.00	0.00	0.00	0.00	0.02)
1991	0.00	0.00	0.00	0.00	0.00	0.00	0.00	0.00	0.00	0.00	0.00	0.00	0.00
(OBS. =	0.00	0.00	0.00	0.00	0.00	0.00	0.00	0.00	0.00	0.00	0.00	0.00	0.00)
1992	0.00	0.00	0.89	0.30	0.00	0.00	0.00	0.00	0.00	0.00	0.00	0.00	1.18
(OBS. =	0.00	0.00	0.09	0.60	1.20	0.20	0.09	0.07	0.07	0.07	0.01	0.01	2.41)

1993	0.00	0.02	0.01	0.00	0.00	0.00	0.00	0.00	0.00	0.00	0.00	0.00	0.03
(OBS. =	0.00	0.00	0.02	0.00	0.00	0.00	0.00	0.00	0.00	0.00	0.00	0.00	0.02)
1994	0.00	0.00	0.00	0.24	0.08	0.00	0.00	0.00	0.00	0.00	0.00	0.00	0.33
(OBS. =	0.00	0.00	0.01	0.00	0.00	0.00	0.00	0.00	0.00	0.00	0.00	0.00	0.01)
1995	0.00	0.00	0.00	1.20	5.59	1.73	0.00	0.00	0.00	0.00	0.00	0.00	8.51
(OBS. =	0.00	0.00	0.00	0.94	5.38	0.05	0.01	0.02	0.02	0.00	0.00	0.00	6.42)
1996	0.00	0.00	0.00	0.33	0.13	0.01	0.00	0.00	0.00	0.00	0.00	0.00	0.46
(OBS. =	0.00	0.01	0.02	0.00	0.00	0.00	0.00	0.00	0.00	0.00	0.00#	0.00#	0.03)
1997	0.00	0.15	0.05	0.02	0.01	0.00	0.00	0.00	0.00	0.00	0.00	0.00	0.23
(OBS. =	0.00	0.00	0.00	0.00	0.00	0.00	0.00	0.00	0.00	0.00	0.00	0.00	0.00)
1998	0.00	0.00	2.19	1.08	0.31	0.07	0.00	0.00	0.00	0.00	0.00	0.00	3.65
(OBS. =	0.00	0.01	0.01	1.11	10.60+	0.02	0.01	0.00	0.00	0.00	0.00	0.00	11.76)
1999	0.00	0.01	0.02	1.49	59.03	20.35	0.28	0.00	0.00	0.00	0.00	0.00	81.17
(OBS. =	0.00	0.00	0.00	2.23	55.17#	3.79	0.53	0.41	0.01	0.06	0.11	0.05	62.36)
2000	0.00	0.00	0.00	0.00	3.17	1.07	0.00	0.00	0.00	0.00	0.00	0.00	4.25
(OBS. =	0.02	0.14	0.02	0.01	0.20	1.17	0.10	0.04	0.02	0.01	0.00#	0.00#	1.73)
% TOTAL	0.18	1.10	7.47	13.83	56.85	19.73	0.68	0.00	0.00	0.00	0.00	0.16	100.00
(OBS. =	0.16	1.61	3.84	19.21	64.21	8.99	0.88	0.37	0.10	0.12	0.10	0.42	100.00

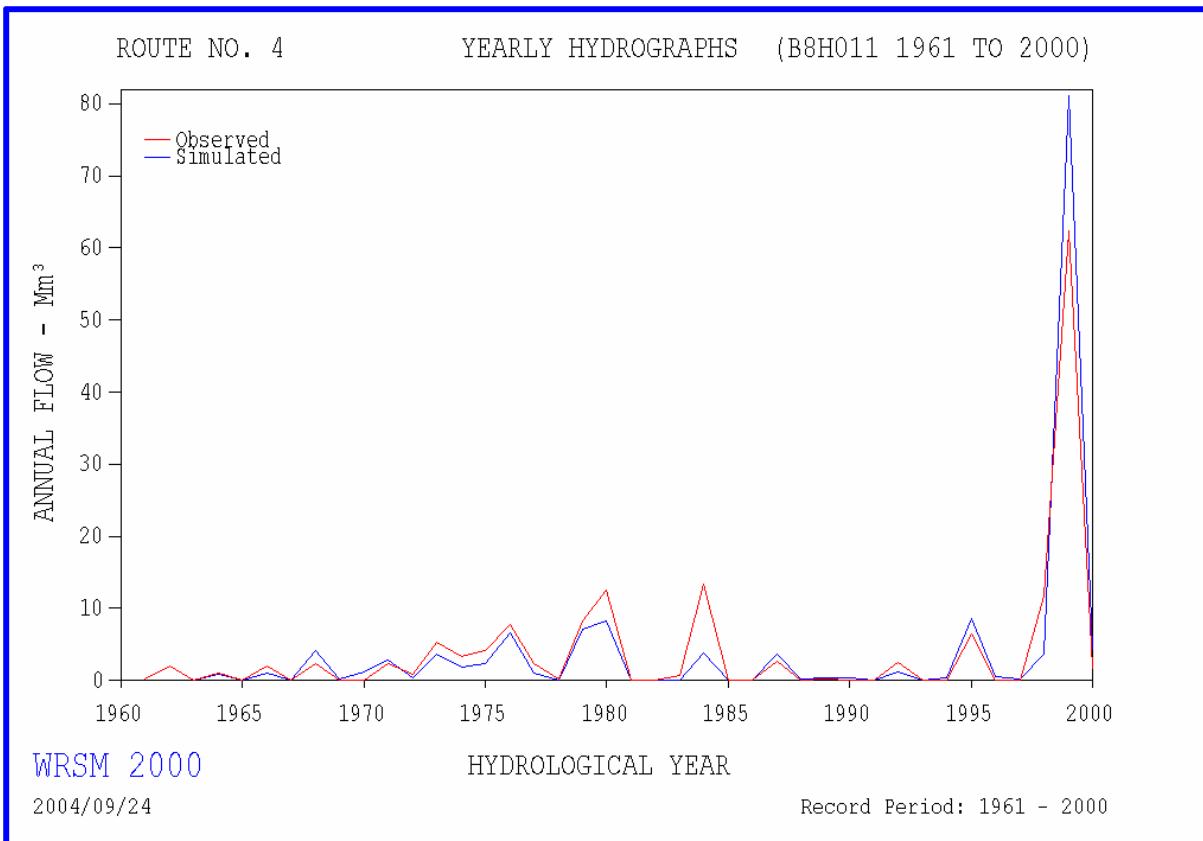
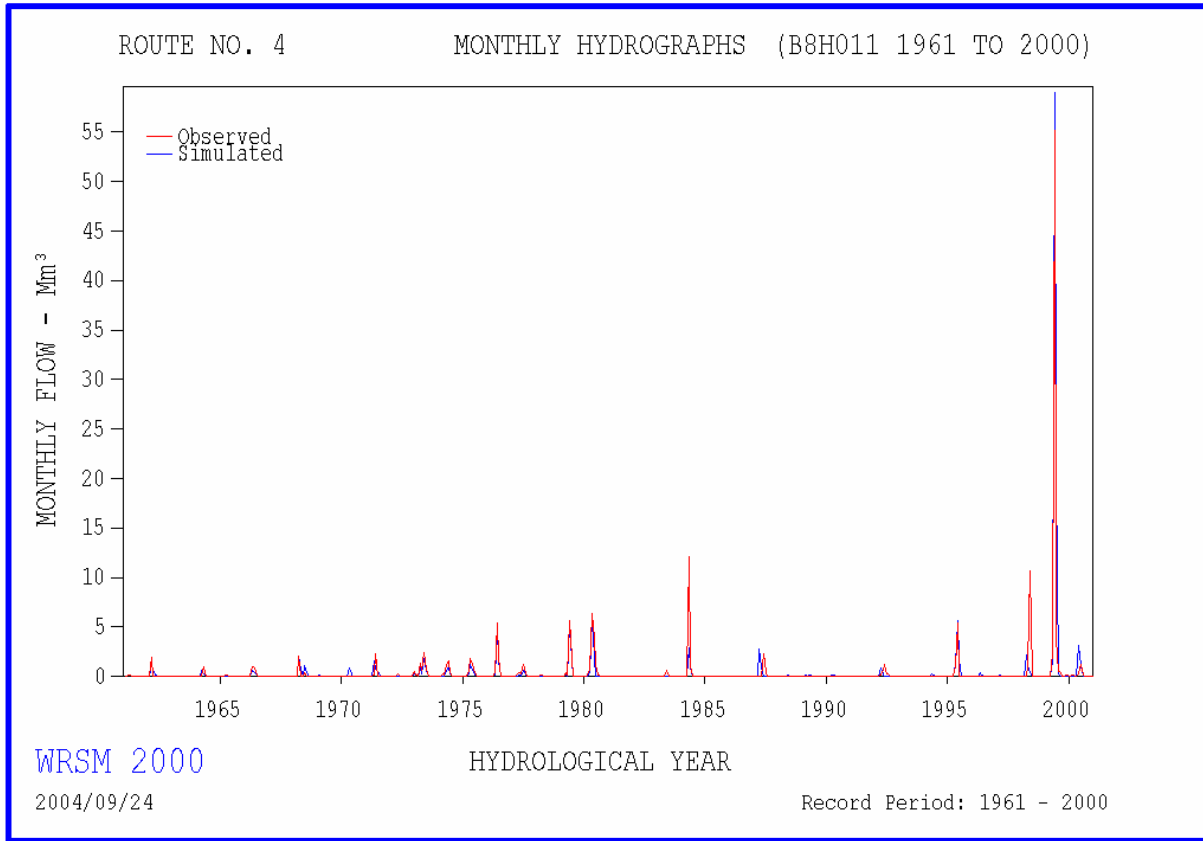

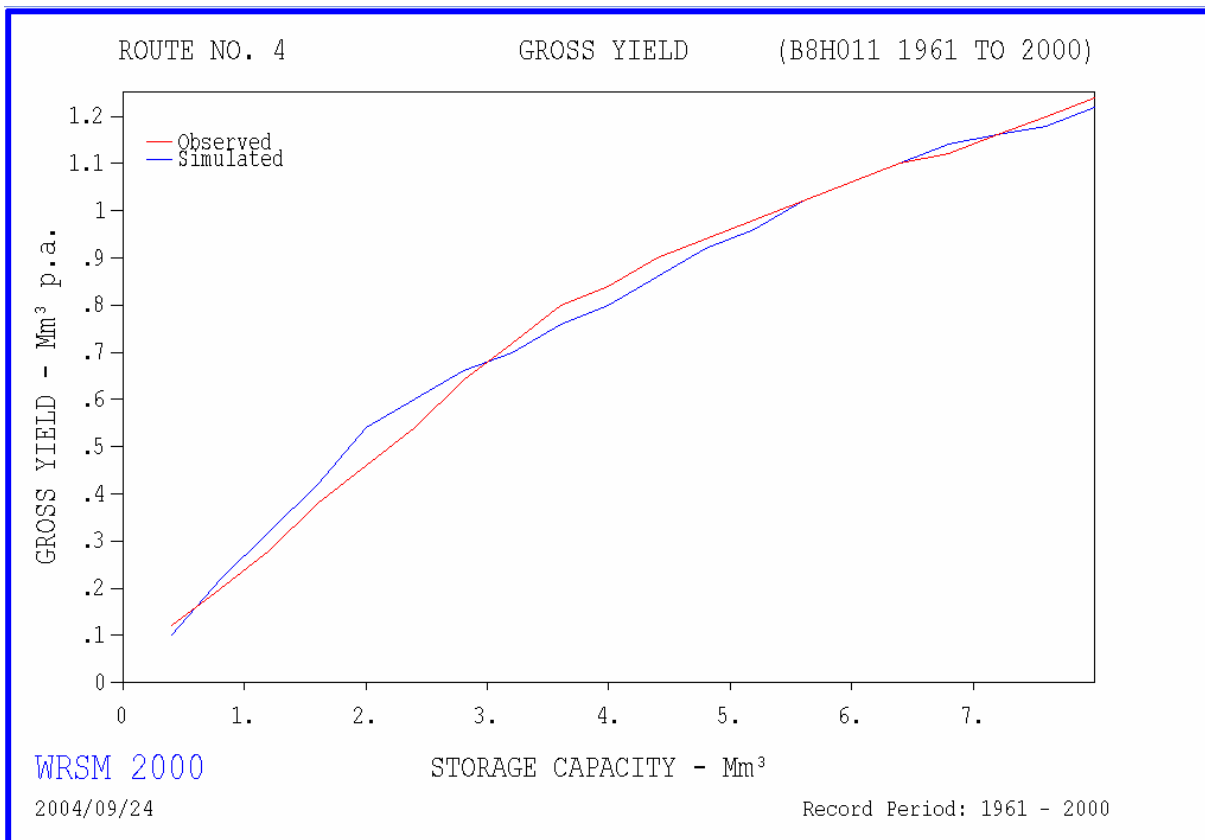
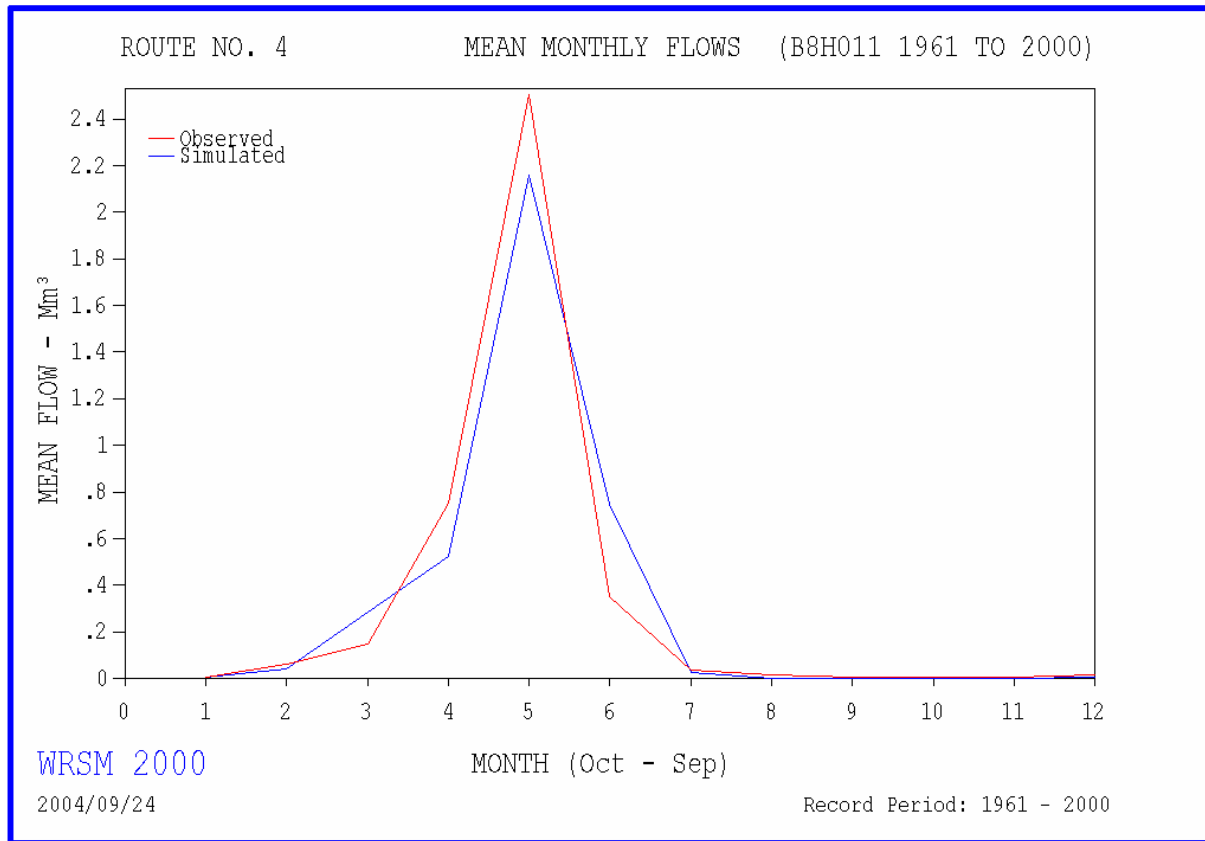

Appendix D

Existing and Extended Monthly Flow Time Series Data

Simulated Natural River Flow B81D (units – million cubic meters) Pre Feasibility Study 1994 (1925 to 1992)

Year	Oct	Nov	Dec	Jan	Feb	Mar	Apr	May	Jun	Jul	Aug	Sep	Sum
1925	2.49	2.34	2.25	3.36	7.67	8.19	6.61	5.06	3.85	3.29	3	2.53	50.64
1926	1.98	1.61	1.52	2.21	2.34	2.2	2.01	1.82	1.61	1.5	1.45	1.38	21.63
1927	3.36	3.3	3.18	32.16	18.54	6.79	5.38	4.48	3.55	2.84	2.41	2.09	88.08
1928	1.75	2.68	2.84	3.72	7.14	11.94	8.92	6.11	4.62	3.72	3.09	2.57	59.1
1929	2.34	2.88	4.78	4.9	5.23	9.58	8.87	7.09	5.58	4.46	3.62	2.93	62.26
1930	2.29	1.89	23.67	19.13	9.25	7.94	9.12	8.15	6.14	5.12	4.6	3.71	101
1931	2.82	3.48	3.63	4.18	4.24	4.3	4.21	3.87	3.36	2.77	2.26	1.83	40.95
1932	1.54	1.38	2.64	22.39	13.86	6.36	5.36	4.28	3.3	2.63	2.22	1.83	67.79
1933	1.51	12.32	9.72	21.37	14.51	9.13	7.9	6.33	4.89	3.91	3.16	2.56	97.31
1934	2.14	2.72	5.52	5.61	5.09	4.68	3.91	3.27	2.86	2.52	2.19	1.87	42.38
1935	1.63	1.38	1.29	3.09	7.95	10.68	7.78	5.97	5.01	4.11	3.33	2.84	55.06
1936	2.64	4.24	5.59	11.89	75.71	38.15	9.39	6.44	4.67	3.6	2.9	2.41	167.6
1937	1.99	1.61	4.06	6.93	5.66	4.29	12.31	9.3	5.75	4.64	3.75	3.23	63.52
1938	5.74	5.63	39.46	41.36	85.29	58.25	18.27	7.65	5.89	5.12	4.63	4.25	281.5
1939	3.82	13	15.71	9.79	6.88	9.19	8.97	7.37	6.09	5.14	4.22	3.7	93.88
1940	3.4	3.98	8.19	6.91	5.04	4.39	6.37	5.99	4.5	3.45	2.79	2.27	57.28
1941	1.86	1.67	2.45	3.03	2.96	8.89	7.19	4.7	3.95	3.37	2.85	2.6	45.52
1942	2.63	2.79	3.44	3.33	3.07	5.32	17.06	11.33	6.31	4.98	4.58	4.28	69.12
1943	3.53	3.2	3.04	4.3	35.04	20.27	7.94	5.79	4.53	3.86	3.17	2.53	97.2
1944	3.26	3.35	2.95	5.08	7.66	7.45	6.5	5.27	3.98	3.11	2.53	2.04	53.18
1945	1.91	1.92	2.07	33.73	26.07	11.18	7.96	6.17	4.61	3.56	2.85	2.23	104.3
1946	1.81	1.69	1.67	1.73	6.53	6.11	5.04	4.53	3.7	3.02	2.51	2.05	40.39
1947	1.77	2.34	6.72	6.69	6.13	64.15	33.27	8.39	5.81	4.39	3.44	2.7	145.8
1948	2.76	2.99	2.92	12.84	10.12	6.44	5.27	4.35	3.8	3.31	2.81	2.31	59.92
1949	1.88	2.1	3.74	4.1	5.24	6.99	7.27	6.79	5.78	4.61	3.66	2.91	55.07
1950	2.24	1.9	20.2	12.59	5.02	4.27	4.21	4.73	4.67	3.88	3.2	2.82	69.73
1951	3.08	3	2.65	2.48	2.62	2.68	2.57	2.39	2.1	1.94	1.83	1.6	28.94
1952	1.4	2.23	5.14	23.79	71.78	37.56	12.04	8.66	6.51	4.94	3.94	3.1	181.1
1953	2.41	2.99	4.16	10	14.84	10.13	7.39	6.29	4.99	3.88	3.17	2.65	72.9
1954	2.22	3.11	4.76	34.36	120.38	72.63	19.22	8.69	6.71	5.31	4.19	3.23	284.8
1955	2.87	4.61	17.7	12.08	114.26	76.76	19.67	7.69	6.03	4.99	4	3.57	274.2
1956	3.32	2.94	3.12	3.27	4.23	7.82	7.41	5.89	4.79	4.18	3.92	3.52	54.41
1957	3.52	3.46	3.18	48.55	26.01	7.23	5.84	4.87	3.78	3	2.44	2.34	114.2
1958	2.39	2.64	6.7	7.76	7.41	6.93	5.88	4.51	3.43	2.82	2.4	2.01	54.88
1959	1.77	3.44	5.8	5	7.36	6.77	5.74	5.19	4.36	3.6	2.94	2.45	54.42
1960	2.05	9.68	36.21	19.08	13.39	22.57	15.36	9.11	7.25	6.2	5.33	4.4	150.6
1961	3.53	2.83	2.74	3.23	3.45	3.32	3.2	3.02	2.57	2.14	1.79	1.48	33.3
1962	1.19	2.48	4.3	4.1	3.41	2.89	2.65	2.55	2.57	2.62	2.4	1.99	33.15
1963	1.69	1.68	2.08	2.62	2.96	2.84	2.45	2.15	1.85	1.6	1.38	1.19	24.49
1964	1.42	1.8	14.35	15.27	8.87	6.37	5.26	4.33	3.44	2.74	2.26	2	68.11
1965	1.79	1.8	1.82	4.97	7.52	6.11	4.39	3.33	2.64	2.21	1.91	1.67	40.16
1966	1.71	1.81	3	4.14	11.27	10.51	13.81	10.32	6.69	5.07	3.99	3.1	75.42
1967	2.48	2.85	3	2.64	2.47	3.17	3.62	3.71	3.55	3.24	2.79	2.27	35.79
1968	1.88	2.38	5.13	7.2	6.14	12.98	10.13	6.73	5.16	4.04	3.25	2.65	67.67
1969	4.32	4.27	5.38	4.88	4.27	3.87	3.19	2.62	2.26	2.05	1.87	1.6	40.58
1970	1.47	1.65	2.83	8.98	7.32	5.09	5.49	5.41	4.6	3.71	2.94	2.34	51.83
1971	2.42	3.21	4.14	65.13	72.66	58.39	23.33	8.09	6.06	4.69	3.71	2.91	254.7
1972	2.91	3.18	3.01	2.7	2.65	2.84	3.17	3.2	2.81	2.4	2.1	2.79	33.76
1973	3.48	4.39	11.36	28.61	56.63	31.52	11.75	7.95	6.03	4.79	4.1	3.7	174.3
1974	3.37	3.89	5.49	9.97	20.81	13.91	8.75	7.14	5.65	4.43	3.48	2.73	89.62
1975	2.14	1.84	17.16	45.3	37.38	62.16	29.64	9.41	7.67	6.01	4.56	3.45	226.7
1976	2.76	3.13	3.04	11.93	11.65	26.05	16.08	7.86	5.87	4.44	3.5	3.17	99.48
1977	2.97	2.78	4.47	39.2	30.72	17.91	11.16	7.26	5.33	4.09	3.27	2.64	131.8
1978	2.23	2.92	3.15	3.99	4.1	4.46	4.55	4.21	3.6	2.96	2.79	2.77	41.73
1979	2.79	3.15	5.24	7.5	39.57	22.24	8.12	5.97	4.44	3.47	2.91	2.75	108.2
1980	2.8	6.63	8.27	56.84	63.11	27.84	10.93	7.37	5.48	4.17	3.39	2.88	199.7
1981	2.68	3.36	3.67	4.23	3.92	3.16	2.72	2.62	2.45	2.14	1.86	1.59	34.4
1982	1.43	1.59	1.85	1.98	1.91	2.15	2.21	1.92	1.64	1.45	1.38	1.29	20.8
1983	1.33	1.89	2.37	2.32	2.18	3.92	4.01	3.31	2.66	2.66	2.82	2.63	32.1
1984	3.02	6.64	5.81	6.05	15.62	11.86	7.83	6.21	5.28	4.61	3.79	3.28	80
1985	3.31	3.14	3.13	3.18	3.4	3.49	6.82	6.36	4.69	3.67	2.99	2.45	46.63
1986	2.17	2.68	4.59	4.81	5.57	5.76	5.25	4.44	3.68	3.1	2.64	2.9	47.59
1987	3.15	3.18	11.09	8.92	29.4	56.66	26.31	7.69	5.51	4.57	3.78	3.24	163.5
1988	4.25	4.17	3.6	3.31	5.85	5.6	4.56	3.78	3.18	2.79	2.41	1.99	45.49
1989	1.9	2.95	5.01	8.71	9.83	8.68	7.8	6.61	5.1	3.96	3.19	2.53	66.27
1990	2.16	2.22	4.52	11.47	10.21	15.61	10.99	6.48	4.9	3.97	3.19	2.55	78.27
1991	2.01	1.8	1.7	1.59	1.43	1.41	1.4	1.25	1.09	1	0.94	0.88	16.5
1992	0.81	0.78	3.36	2.85	2.16	3.93	3.92	3.1	2.51	2.13	1.85	1.61	29.01
Ave	2.62	3.4	6.32	11.49	20.09	16.28	8.92	5.89	4.69	3.88	3.27	2.56	86.06
SD	0.86	2.16	7.17	14.24	26.21	18.63	6.51	2.24	1.49	1.13	0.89	0.74	65.61

**Simulated Natural River Flow B81D (units – million cubic meters)
This Study September 2004 (1920 to 2001) Based on updated Calibration (LETRQ10.ANS)**

Year	Oct	Nov	Dec	Jan	Feb	Mar	Apr	May	Jun	Jul	Aug	Sep	Sum
1920.00	2.98	3.04	5.59	10.90	9.76	15.31	11.27	7.24	5.59	4.58	3.69	2.94	82.90
1921.00	2.35	2.05	1.94	1.82	1.65	1.67	1.70	1.53	1.33	1.21	1.13	1.04	19.41
1922.00	0.96	0.93	3.60	3.08	2.33	3.35	3.50	2.99	2.48	2.14	1.91	1.67	28.94
1923.00	1.50	2.47	4.47	4.41	4.48	4.55	4.16	3.49	2.80	2.31	1.97	1.67	38.28
1924.00	1.63	1.68	2.16	2.93	3.49	4.39	4.78	4.55	3.88	3.17	2.62	2.17	37.43
1925.00	1.82	1.68	1.74	2.86	6.89	7.29	6.16	4.91	3.83	3.34	3.07	2.63	46.23
1926.00	2.10	1.75	1.64	2.27	2.44	2.32	2.15	1.95	1.72	1.61	1.59	1.48	23.02
1927.00	3.33	3.33	3.26	30.57	17.80	7.06	5.72	4.81	3.86	3.12	2.67	2.31	87.83
1928.00	1.96	2.80	2.98	3.82	7.05	11.83	9.00	6.34	4.89	3.99	3.35	2.81	60.82
1929.00	2.55	3.05	4.84	5.01	5.37	9.54	8.93	7.30	5.85	4.73	3.89	3.18	64.26
1930.00	2.53	2.11	22.31	18.34	9.44	8.25	9.39	8.47	6.52	5.49	4.94	4.02	101.81
1931.00	3.10	3.67	3.84	4.36	4.44	4.52	4.43	4.09	3.58	2.99	2.46	2.02	43.51
1932.00	1.71	1.54	2.70	21.18	13.31	6.60	5.64	4.58	3.57	2.89	2.44	2.04	68.19
1933.00	1.70	11.64	9.35	20.83	14.35	9.40	8.25	6.70	5.26	4.25	3.48	2.84	98.03
1934.00	2.40	2.89	5.53	5.69	5.29	4.91	4.15	3.51	3.09	2.73	2.39	2.05	44.63
1935.00	1.80	1.53	1.44	3.09	7.65	10.50	7.86	6.15	5.23	4.34	3.56	3.07	56.21
1936.00	2.86	4.34	5.65	11.65	72.07	36.67	10.07	7.13	5.24	4.08	3.33	2.75	165.84
1937.00	2.29	1.86	4.09	6.81	5.76	4.52	12.06	9.28	6.02	4.94	4.04	3.49	65.15
1938.00	5.83	5.78	37.86	38.78	84.48	58.30	18.82	8.42	6.56	5.70	5.14	4.68	280.37
1939.00	4.22	12.65	15.44	10.07	7.30	9.40	9.24	7.77	6.48	5.53	4.57	4.02	96.67
1940.00	3.70	4.20	8.12	7.00	5.31	4.68	6.50	6.18	4.77	3.73	3.05	2.50	59.74
1941.00	2.08	1.85	2.57	3.15	3.11	8.59	7.12	4.90	4.17	3.59	3.07	2.80	47.01
1942.00	2.84	2.97	3.59	3.48	3.25	5.34	16.68	11.28	6.57	5.27	4.87	4.56	70.70
1943.00	3.81	3.44	3.27	4.43	33.62	19.68	8.30	6.20	4.92	4.22	3.51	2.81	98.22
1944.00	3.45	3.56	3.18	5.14	7.59	7.54	6.72	5.52	4.24	3.37	2.79	2.26	55.35
1945.00	2.11	2.11	2.23	31.96	25.10	11.38	8.32	6.56	4.99	3.91	3.15	2.50	104.31
1946.00	2.03	1.90	1.86	1.89	6.35	6.06	5.19	4.73	3.91	3.23	2.71	2.24	42.13
1947.00	1.94	2.46	6.55	6.62	6.23	60.68	31.81	9.08	6.48	4.96	3.91	3.09	143.81
1948.00	3.08	3.29	3.20	12.33	9.95	6.73	5.60	4.68	4.09	3.61	3.06	2.54	62.16
1949.00	2.10	2.26	3.81	4.20	5.33	7.02	7.38	6.97	6.01	4.86	3.91	3.16	57.00
1950.00	2.47	2.11	19.01	12.08	5.31	4.58	4.50	4.98	4.92	4.15	3.46	3.05	70.63
1951.00	3.28	3.20	2.85	2.68	2.80	2.84	2.75	2.56	2.27	2.10	1.99	1.74	31.08
1952.00	1.52	2.31	5.03	22.80	67.73	35.58	12.50	9.43	7.21	5.52	4.44	3.52	177.58
1953.00	2.75	3.24	4.36	9.81	14.72	10.34	7.73	6.64	5.34	4.21	3.48	2.93	75.55
1954.00	2.47	3.26	4.84	32.92	117.15	71.22	19.69	9.47	7.40	5.90	4.70	3.65	282.66
1955.00	3.23	4.84	17.19	11.99	111.78	75.32	20.15	8.45	6.70	5.58	4.50	3.99	273.70
1956.00	3.69	3.26	3.39	3.54	4.43	7.83	7.53	6.16	5.07	4.46	4.19	3.78	57.32
1957.00	3.76	3.69	3.40	46.41	25.05	7.66	6.30	5.29	4.18	3.34	2.73	2.60	114.39
1958.00	2.64	2.84	6.60	7.69	7.50	7.14	6.14	4.79	3.71	3.07	2.64	2.22	56.97
1959.00	1.97	3.51	5.76	5.09	7.31	6.83	5.96	5.42	4.62	3.86	3.20	2.68	56.19
1960.00	2.26	9.26	34.62	18.57	13.28	21.05	15.01	9.79	7.91	6.78	5.85	4.86	149.23
1961.00	3.91	3.18	3.03	3.48	3.69	3.57	3.44	3.24	2.79	2.34	1.98	1.64	36.28
1962.00	1.33	2.51	4.25	4.16	3.56	3.06	2.81	2.71	2.73	2.77	2.56	2.15	34.61
1963.00	1.84	1.82	2.20	2.71	3.07	2.97	2.60	2.30	2.00	1.73	1.51	1.32	26.07
1964.00	1.53	1.89	13.49	14.65	8.90	6.59	5.52	4.60	3.71	3.01	2.50	2.20	68.60
1965.00	1.99	1.97	1.97	4.88	7.33	6.16	4.58	3.56	2.85	2.41	2.10	1.85	41.65
1966.00	1.87	1.96	3.06	4.16	10.99	10.36	13.28	10.18	6.99	5.39	4.32	3.39	75.94
1967.00	2.73	3.05	3.19	2.86	2.68	3.32	3.79	3.89	3.75	3.43	2.97	2.45	38.10
1968.00	2.05	2.51	5.09	7.08	6.21	12.73	10.10	6.98	5.45	4.33	3.53	2.90	68.97
1969.00	4.44	4.45	5.49	5.05	4.49	4.09	3.43	2.85	2.47	2.26	2.05	1.77	42.85
1970.00	1.62	1.78	2.89	8.62	7.20	5.26	5.63	5.60	4.82	3.93	3.17	2.56	53.08
1971.00	2.61	3.37	4.26	62.71	69.58	57.36	23.80	8.86	6.75	5.27	4.18	3.32	252.06
1972.00	3.25	3.49	3.31	2.96	2.90	3.07	3.38	3.41	3.01	2.59	2.29	2.92	36.56
1973.00	3.61	4.50	11.06	25.91	54.08	30.88	12.29	8.71	6.69	5.37	4.59	4.13	171.83
1974.00	3.75	4.18	5.68	9.90	19.40	13.67	9.47	7.84	6.25	4.94	3.93	3.11	92.10
1975.00	2.46	2.11	16.23	43.09	36.66	62.52	30.35	10.19	8.38	6.63	5.09	3.90	227.62
1976.00	3.13	3.43	3.33	11.50	11.44	23.99	15.36	8.50	6.48	4.97	3.95	3.56	99.64
1977.00	3.31	3.08	4.64	37.57	28.60	17.30	11.67	7.98	5.94	4.61	3.72	3.01	131.44
1978.00	2.54	3.16	3.39	4.19	4.31	4.66	4.77	4.45	3.84	3.20	3.02	2.98	44.53
1979.00	2.98	3.32	5.29	7.44	36.42	20.94	8.75	6.59	4.98	3.92	3.30	3.08	107.01
1980.00	3.11	6.65	8.25	53.92	61.59	27.90	11.49	8.13	6.14	4.72	3.85	3.28	199.03
1981.00	3.03	3.63	3.95	4.46	4.17	3.42	2.97	2.86	2.67	2.34	2.04	1.76	37.29
1982.00	1.59	1.73	1.98	2.11	2.04	2.26	2.33	2.05	1.76	1.58	1.50	1.40	22.34
1983.00	1.42	1.97	2.44	2.42	2.29	3.91	4.07	3.44	2.80	2.81	2.97	2.78	33.31
1984.00	3.14	6.53	5.83	6.11	15.27	11.79	8.08	6.53	5.61	4.91	4.09	3.57	81.46
1985.00	3.57	3.39	3.33	3.37	3.58	3.70	6.80	6.43	4.92	3.92	3.22	2.67	48.91
1986.00	2.38	2.84	4.64	4.90	5.67	5.90	5.46	4.68	3.92	3.32	2.86	3.08	49.64
1987.00	3.34	3.37	10.66	8.76	27.23	55.43	26.80	8.45	6.17	5.12	4.26	3.65	163.25
1988.00	4.56	4.47	5.91	3.60	5.94	5.78	4.83	4.06	3.44	3.03	2.62	2.20	48.44
1989.00	2.08	3.07	3.04	8.52	9.77	8.79	8.01	6.87	5.39	4.25	3.47	2.79	68.04
1990.00	2.39	2.44	4.57	11.11	10.07	15.05	11.02	7.01	5.39	4.41	3.57	2.87	79.90
1991.00	2.29	2.03	1.92	1.78	1.61	1.57	1.55	1.39	1.21	1.11	1.05	0.97	18.49
1992.00	0.89	0.86	3.24	2.83	2.26	3.91	3.96	3.22	2.64	2.27	2.01	1.74	29.82
1993.00	1.49	2.12	3.87	3.56	4.65	4.66	4.28	3.82	3.13	2.56	2.16	1.82	38.12
1994.00	1.66	1.61	1.86	2.42	3.84	4.28	4.43	4.27	3.61	2.94	2.44	2.02	35.38
1995.00	1.71	2.92	4.38	10.02	97.30	47.32	10.43	8.42	7.33	6.39	5.77	4.84	206.83
1996.00	3.95	3.81	9.35	24.39	19.33	29.62	17.58	8.35	6.23	4.84	3.83	3.27	134.57
1997.00	3.21	3.36	3.43	5.89	5.54	4.47	3.78	3.15	2.55	2.25	2.13	1.96	41.74
1998.00	1.95	2.66	20.15	17.51	10.01	9.56	9.04	7.67	6.31	5.41	4.69	3.74	98.69
1999.00	2.95	3.67	8.87	26.02	243.40	167.28	38.50	10.18	8.12	7.26	5.95	4.79	526.98
2000.00	4.31	4.14	6.30	5.63	15.20	11.45	7.27	5.81	4.67	3.84	3.17	2.59	74.38
2001.00	2.48	15.37	12.45	7.95	6.84	5.74	4.59	3.65	3.06	2.73	2.39	2.08	69.34
Ave	2.62	3.40	6.32	11.49	20.09	16.28	8.92	5.89	4.69	3.88	3.27	2.79	89.64
SD	0.91	2.34	6.49	12.72	35.37	24.19	6.99	2.39	1.70	1.34	1.08	0.88	79.25

Simulated developed River Flow B81D (units – million cubic meters)

Feasibility Study 1998 (1925 to 1992) Generate from WRYM

Year	Oct	Nov	Dec	Jan	Feb	Mar	Apr	May	Jun	Jul	Aug	Sep	Sum
1925	0.99	0.88	0.70	2.08	5.82	6.35	4.59	3.17	2.25	1.98	0.91	0.68	30.38
1926	0.34	0.21	0.18	1.08	1.03	0.92	0.54	0.21	0.23	0.25	0.00	0.00	4.98
1927	1.28	1.19	1.09	26.64	15.30	5.13	3.88	2.68	2.02	1.44	0.52	0.35	61.52
1928	0.20	1.02	0.93	2.27	5.26	9.87	6.72	4.03	3.00	2.21	1.05	0.76	37.30
1929	0.76	1.20	2.60	3.34	3.72	7.71	6.81	4.94	3.86	2.91	1.49	1.08	40.43
1930	0.62	0.39	19.47	16.27	7.69	6.71	7.64	6.14	4.57	3.88	2.42	1.72	77.52
1931	1.11	1.84	1.56	2.88	2.71	2.87	2.54	2.06	1.68	1.25	0.28	0.11	20.90
1932	0.05	0.05	0.70	18.22	11.11	4.83	3.73	2.47	1.79	1.26	0.30	0.14	44.66
1933	0.06	9.02	6.89	19.05	12.47	7.80	6.44	4.64	3.50	2.53	1.23	0.82	74.44
1934	0.64	1.12	3.22	4.03	3.60	3.10	2.22	1.63	1.29	1.12	0.25	0.13	22.35
1935	0.10	0.04	0.04	1.64	5.16	8.42	5.65	3.97	3.23	2.49	1.18	1.01	32.93
1936	0.95	2.47	3.29	9.77	69.28	34.07	7.90	4.86	3.33	2.35	1.03	0.76	140.07
1937	0.48	0.23	1.84	4.99	3.83	2.78	9.94	6.52	3.88	2.93	1.53	1.38	40.33
1938	3.79	3.46	35.09	37.19	82.08	55.32	16.20	6.21	4.55	3.99	2.64	2.55	253.08
1939	2.05	10.37	12.80	8.15	5.62	7.87	7.31	5.58	4.76	3.69	2.22	2.00	72.43
1940	1.67	2.39	5.72	5.06	3.63	2.95	4.63	3.67	2.70	1.87	0.75	0.44	35.50
1941	0.29	0.23	0.64	1.65	1.47	6.32	4.74	2.75	2.26	1.76	0.77	0.77	23.65
1942	0.94	1.04	1.38	1.83	1.64	3.74	14.18	8.33	4.19	3.31	2.46	2.14	45.17
1943	1.57	1.50	1.12	2.82	31.04	17.02	6.03	3.91	3.13	2.38	1.15	0.74	72.42
1944	1.63	1.53	1.11	3.48	5.79	5.63	4.65	3.27	2.36	1.65	0.57	0.28	31.93
1945	0.44	0.39	0.51	29.00	22.87	9.59	6.35	4.45	3.14	2.19	0.93	0.52	80.38
1946	0.34	0.29	0.29	0.73	4.04	4.11	3.26	2.48	1.99	1.48	0.46	0.25	19.72
1947	0.21	0.72	3.99	4.84	4.50	58.06	28.80	6.63	4.39	3.06	1.51	0.97	117.68
1948	1.29	1.38	1.08	10.22	7.95	4.82	3.65	2.71	2.32	1.86	0.79	0.55	38.61
1949	0.30	0.57	1.57	2.54	3.74	5.25	5.35	4.76	3.96	2.95	1.54	1.02	33.56
1950	0.57	0.40	16.14	9.99	3.50	3.08	2.81	3.08	2.91	2.29	1.16	0.96	46.89
1951	1.44	1.14	0.88	1.27	1.32	1.23	0.97	0.63	0.62	0.57	0.00	0.00	10.08
1952	0.00	0.57	2.40	19.84	64.78	32.97	10.35	7.03	5.13	3.67	2.04	1.33	150.13
1953	0.86	1.44	2.17	7.93	12.87	8.34	5.90	4.50	3.44	2.45	1.26	0.85	52.01
1954	0.67	1.42	2.61	30.51	114.71	68.04	17.03	7.17	5.40	4.03	2.26	1.46	255.30
1955	1.40	3.03	14.65	9.95	109.75	71.92	17.25	6.25	4.77	3.67	2.10	2.00	246.75
1956	1.62	1.33	1.27	2.04	2.90	6.02	5.30	3.89	3.12	2.76	1.78	1.53	33.55
1957	1.86	1.59	1.21	43.63	22.41	5.88	4.49	3.15	2.35	1.64	0.56	0.74	89.50
1958	0.75	1.03	4.24	5.88	5.75	5.28	4.08	2.67	1.90	1.45	0.46	0.30	33.77
1959	0.26	1.58	3.41	3.26	5.68	4.83	4.10	3.24	2.74	2.06	0.89	0.65	32.70
1960	0.42	6.93	31.90	16.29	11.98	20.51	13.60	7.41	6.01	4.94	3.40	2.57	125.94
1961	1.81	1.25	0.98	2.01	2.07	1.85	1.74	1.20	0.98	0.71	0.00	0.00	14.59
1962	0.00	0.75	1.85	2.44	1.82	1.44	1.11	0.82	1.09	1.04	0.29	0.14	12.79
1963	0.10	0.18	0.45	1.31	1.48	1.29	0.84	0.46	0.40	0.31	0.00	0.00	6.83
1964	0.00	0.24	9.38	12.18	6.99	4.70	3.70	2.51	1.89	1.33	0.36	0.32	43.59
1965	0.22	0.30	0.35	2.98	5.37	4.00	2.60	1.48	1.12	0.80	0.08	0.02	19.33
1966	0.22	0.30	0.97	2.46	8.86	8.33	11.48	7.70	4.75	3.42	1.83	1.15	51.46
1967	0.85	1.18	1.06	1.36	1.23	1.68	1.92	1.87	1.90	1.59	0.63	0.36	15.65
1968	0.25	0.73	2.67	5.28	4.17	10.75	7.79	4.65	3.47	2.53	1.19	0.84	44.33
1969	2.52	2.32	3.24	3.23	2.89	2.27	1.58	0.92	0.80	0.70	0.04	0.00	20.52
1970	0.02	0.19	0.82	6.19	5.09	3.44	3.80	3.30	2.78	2.06	0.82	0.50	29.00
1971	0.85	1.45	2.01	59.89	67.22	54.92	21.08	6.61	4.69	3.38	1.82	1.15	225.08
1972	1.46	1.60	1.15	1.54	1.36	1.45	1.59	1.34	1.15	0.93	0.16	0.98	14.71
1973	1.62	2.45	8.18	23.74	52.61	29.04	10.05	6.40	4.67	3.63	2.20	2.07	146.65
1974	1.68	2.36	3.37	8.04	17.76	11.81	7.37	5.58	4.25	3.08	1.58	1.01	67.90
1975	0.64	0.40	13.49	41.05	33.77	59.58	27.60	8.01	6.24	4.67	2.62	1.66	199.72
1976	1.22	1.65	1.15	9.47	9.55	22.61	13.22	6.14	4.41	3.08	1.60	1.57	75.67
1977	1.27	1.18	2.47	35.02	27.13	15.72	9.32	5.64	3.96	2.82	1.37	0.94	106.83
1978	0.72	1.35	1.20	2.69	2.59	3.06	2.86	2.35	1.92	1.43	0.92	0.79	21.89
1979	1.06	1.38	2.98	5.56	33.81	18.25	6.48	4.26	2.99	2.15	1.02	1.09	81.03
1980	1.18	4.65	5.73	52.08	58.93	25.43	9.35	5.87	4.15	2.90	1.59	1.20	173.06
1981	1.20	1.86	1.68	2.99	2.30	1.72	1.29	1.01	0.88	0.74	0.02	0.00	15.69
1982	0.00	0.15	0.33	0.85	0.76	0.90	0.59	0.26	0.25	0.21	0.00	0.00	4.31
1983	0.00	0.31	0.59	1.00	0.94	2.15	1.86	1.23	0.97	1.18	0.53	0.57	11.33
1984	1.11	3.68	2.80	4.20	12.57	9.60	5.79	4.41	3.72	3.05	1.66	1.51	54.08
1985	1.66	1.33	1.20	1.85	1.98	2.00	4.72	3.80	2.74	1.95	0.84	0.54	24.60
1986	0.54	0.98	2.30	3.21	3.99	4.04	3.43	2.52	2.07	1.54	0.63	1.16	26.39
1987	1.31	1.39	7.97	6.74	25.32	52.20	23.67	6.10	4.32	3.26	1.90	1.55	135.73
1988	2.74	2.28	1.70	2.09	4.33	3.82	2.88	1.94	1.71	1.28	0.42	0.20	25.40
1989	0.39	1.22	2.70	6.60	7.85	6.97	6.03	4.62	3.43	2.48	1.16	0.72	44.17
1990	0.65	0.69	2.26	9.18	8.16	13.68	8.87	4.81	3.56	2.62	1.25	0.84	56.55
1991	0.46	0.37	0.32	0.61	0.53	0.48	0.07	0.00	0.00	0.00	0.00	0.00	2.85
1992	0.00	0.00	1.07	1.33	0.93	2.16	1.77	1.12	0.89	0.68	0.01	0.00	9.97
Ave	0.88	1.53	4.08	10.14	16.05	13.10	6.85	3.82	2.87	2.17	1.07	0.83	63.39
SD	0.75	1.84	6.53	13.14	25.07	17.76	6.18	2.18	1.50	1.13	0.80	0.65	62.73

**Simulated Natural River Flow B81D (units – million cubic meters) (LETRQ29.ANS)
This Study September 2004 (1920 to 2001) Based on updated Calibration, WRSM2000**

Year	Oct	Nov	Dec	Jan	Feb	Mar	Apr	May	Jun	Jul	Aug	Sep	Sum
1920	1.03	1.06	2.49	7.98	7.2	13.59	8.98	5.46	4.15	2.54	1.24	0.6	56.32
1921	0.13	0.21	0	0	0	0.06	0.11	0.02	0	0	0	0	0.51
1922	0	0	1.04	0.46	0.28	1.9	1.46	1.03	0.7	0.26	0	0	7.14
1923	0	1.15	1.53	1.91	2.4	2	2.13	1.41	0.9	0.33	0	0	13.75
1924	0.1	0	0	1.25	1.54	2.5	2.98	2.42	1.68	0.93	0.19	0	13.59
1925	0	0	0	1.41	4.86	5.15	3.53	2.73	1.76	1.77	0.44	0.16	21.81
1926	0	0	0	0.82	0.22	0.08	0.62	0.32	0.12	0.03	0	0	2.2
1927	2.16	0.85	0.06	25.23	13.5	4.05	4.06	2.73	1.87	1.09	0.46	0	56.07
1928	0	1.47	0	2.13	5.49	9.86	6.47	4.04	3.1	1.96	0.94	0.42	35.87
1929	0.84	1.4	2.15	2.88	3.61	8.02	7.45	5.1	3.96	2.72	1.31	0.79	40.24
1930	0.05	0.17	19.31	16.06	7.36	6.78	8.67	6.31	4.68	4.31	2.3	1.36	77.38
1931	0.8	2.33	0.53	2.77	2.14	2.6	2.83	2.53	1.63	0.84	0.02	0	19.02
1932	0	0	0.15	17.71	10.2	4.3	3.93	2.61	1.72	0.95	0.14	0	41.7
1933	0	9.4	6.06	19.2	12.05	7.55	6.8	4.92	3.68	2.31	1.13	0.49	73.6
1934	0.49	1.43	2.99	3.72	3.16	2.35	2.23	2.14	1.25	0.89	0	0	20.66
1935	0	0	0	1.72	5.43	8.34	5.58	4.45	3.23	2.19	0.99	0.94	32.88
1936	0.88	3.06	2.73	10.1	66.4	32.26	8.38	5.43	3.61	2.3	1.05	0.56	136.77
1937	0.19	0	1.55	5.32	3.04	2.04	10.67	6.6	4.14	2.7	1.4	1.49	39.13
1938	4.89	3.26	34.8	35.31	81.3	55.65	16.78	7.26	5.12	4.61	2.86	2.99	254.84
1939	2.01	11.09	12.6	7.55	5.29	8.42	8.12	5.91	5.4	3.45	2.3	2.24	74.39
1940	1.56	2.84	5.68	4.18	3.11	2.33	5.6	3.77	2.67	1.54	0.64	0	33.91
1941	0.02	0	0	1.32	0.59	6.5	4.47	3.13	2.37	1.44	0.67	0.78	21.29
1942	1.03	0.9	0.59	0.88	1.2	4.06	14.71	8.36	4.11	3.36	2.86	1.94	44
1943	1.18	1.58	0	2.91	30.44	16.03	6.2	4.13	3.64	2.09	1.04	0.34	69.59
1944	2.45	1.23	0	3.78	6.04	5.42	4.88	3.38	2.29	1.37	0.36	0	31.2
1945	0.62	0	0	28.11	22.43	9.47	6.59	4.72	3.24	1.92	0.8	0.01	77.91
1946	0.13	0.08	0	0.11	4.36	3.81	3.59	2.55	1.99	1.15	0.19	0	17.96
1947	0	1	3.75	4.58	4.28	55.13	27.46	7.25	4.72	3.06	1.51	0.69	113.43
1948	1.92	1.32	0	10.45	7.65	4.16	3.91	3.24	2.57	1.64	0.61	0.21	37.69
1949	0	0.76	1.03	2.14	3.81	5.41	6.06	5.29	3.95	2.64	1.43	0.6	33.12
1950	0.09	0.23	16.11	8.98	2.52	2.85	3.4	4.23	2.84	1.97	1.2	0.79	45.21
1951	1.95	0.48	0	0.62	0.89	0.56	1.3	0.8	0.62	0.45	0	0	7.67
1952	0	0.95	2.08	19.53	61.32	31.42	11.72	8.01	5.7	3.91	2.27	1.09	147.99
1953	0.69	1.96	1.69	8.39	13.12	7.77	6.62	4.88	3.52	2.15	1.37	0.42	52.57
1954	0.56	1.85	2.15	30.05	112.26	67.65	18.31	8.13	6	4.14	2.33	1.24	254.66
1955	1.84	3.77	14.89	9.31	108.02	71.18	17.8	7.4	5.54	3.75	2.24	2.47	248.2
1956	1.52	1.19	0.51	1.61	2.97	6.4	5.72	4.24	3.26	2.96	1.89	1.36	33.63
1957	2.29	1.24	0	42.54	20.88	5.54	5.13	3.42	2.47	1.38	0.38	1.07	86.34
1958	0.6	1.12	4.15	5.97	5.66	4.82	4.1	2.83	1.91	1.25	0.23	0	32.65
1959	0.09	2.17	3.02	2.32	5.99	4.16	4.75	3.5	2.89	1.69	0.73	0.39	31.71
1960	0.02	7.52	31.69	14.99	12.19	18.97	13.81	8.09	6.9	5.24	3.7	2.57	125.68
1961	1.65	1.02	0.05	1.83	1.61	1.23	2.19	1.41	0.91	0.35	0	0	12.24
1962	0	1.32	1.38	1.79	0.81	0.76	1.41	1.18	1.55	0.81	0.04	0	11.04
1963	0	0	0	0.9	1.03	0.23	1.03	0.61	0.26	0	0	0	4.06
1964	0.25	0.07	9.48	11.95	6.12	3.62	3.81	2.52	1.79	0.93	0.17	0.2	40.9
1965	0	0.24	0	3.27	5.53	2.86	2.48	1.53	1.11	0.47	0	0	17.47
1966	0.28	0	0.36	2.3	8.95	8.02	11.5	7.5	4.72	3.24	1.72	0.67	49.26
1967	0.78	1.44	0	0.36	0.79	1.73	2.46	2.35	2.07	1.26	0.45	0	13.7
1968	0	1.02	2.27	5.24	3.26	10.94	8.05	4.81	3.51	2.26	1.03	0.52	42.91
1969	3.55	2.03	2.79	2.3	2.53	1.38	1.56	1.23	0.84	0.53	0	0	18.76
1970	0	0.06	0.17	6.34	4.2	2.73	4.58	3.63	2.79	1.65	0.59	0.11	26.85
1971	1.22	1.67	1.23	58.57	64.82	54.95	22.04	7.72	5.12	3.39	1.99	0.85	223.58
1972	2.12	1.67	0	0.97	0.91	1.15	2.19	1.62	1.08	0.72	0	1.67	14.09
1973	1.88	2.65	8.14	23.44	50.1	27.88	11.12	7.5	5.23	4.11	2.46	2.52	147.05
1974	1.65	2.92	3.09	8.58	17.76	11.46	8.05	6.21	4.54	2.9	1.55	0.63	69.32
1975	0.35	0.14	13.57	39.76	34.32	60.23	28.33	9.62	6.75	4.72	2.77	1.43	201.98
1976	1.29	2.06	0	9.75	9.62	21.85	13.33	6.98	4.82	3.06	1.77	1.97	76.51
1977	1.11	1.21	2.17	34.44	25.41	16.68	10.72	6.37	4.3	2.83	1.4	0.71	107.35
1978	0.7	1.78	0.14	2.71	2.03	3.01	3.28	2.8	1.86	1.11	1.39	0.46	21.27
1979	1.3	1.43	2.57	5.77	32.05	16.82	7.22	4.87	3.28	2.13	1.18	1.34	79.97
1980	1.39	5.56	5.44	50.18	57.48	25.55	10.13	6.82	4.63	2.96	1.91	1.08	173.12
1981	1.53	2.26	0.75	2.9	1.26	0.97	1.61	1.55	0.81	0.45	0	0	14.09
1982	0	0.04	0	0.12	0	0.73	0.49	0.32	0.22	0	0	0	1.93
1983	0	0.43	0	0.02	0.22	2.42	2.04	1.26	0.88	1.67	0.42	0.38	9.74
1984	1.57	4.45	1.17	4.35	12.59	8.86	5.28	4.77	3.8	2.66	1.35	1.64	52.5
1985	1.91	0.82	0.28	1.32	1.67	1.51	5.39	3.93	2.71	1.56	0.75	0.13	21.98
1986	0.53	1.19	1.81	2.78	3.98	3.6	3.65	2.75	2.21	1.13	0.61	1.61	25.85
1987	1.31	1.21	8.06	6.2	24.93	50.02	23	6.64	5.09	3.27	2.09	1.66	133.47
1988	3.73	1.87	0.68	1.55	4.7	3.2	3.16	2.15	1.98	0.93	0.29	0	24.23
1989	0.53	1.58	2.21	6.94	7.8	6.79	6.52	4.83	3.43	2.25	1.03	0.23	44.13
1990	0.69	0.62	1.88	9.44	8.01	13.52	8.52	5.08	3.87	2.32	1.1	0.51	55.57
1991	0.05	0.26	0	0	0	0	0	0	0	0	0	0	0.31
1992	0	0	0.73	0.29	0.33	2.42	1.72	1.21	0.81	0.35	0	0	7.86
1993	0	0.78	1.04	0.63	3	2.08	2.52	1.66	1.14	0.49	0	0	13.33
1994	0	0	0	0.78	2.22	1.97	2.84	2.08	1.46	0.75	0.02	0	12.12
1995	0	1.61	1.36	7.87	88.18	41.83	9.37	7.66	5.77	5.23	3.7	2.23	174.83
1996	2.16	2.15	7.11	22.37	16.65	28.68	16.28	6.91	4.62	3.01	1.48	1.48	112.91
1997	1.67	1.53	0.22	4.63	2.92	1.86	2.18	1.2	0.75	0.74	0	0	17.71
1998	0.25	1.11	17.01	15.23	7.71	8.16	7.48	6.07	4.65	3.9	2.12	1.15	74.84
1999	0.86	2.36	6.51	23.87	240.87	164.52	37.06	8.63	7.67	5.26	3.53	2.72	503.85
2000	2.71	2.18	3.86	2.81	13.38	8.67	5.38	4.11	2.94	1.85	0.74	0.21	48.85
2001	1.07	13.23	9.05	5.88	4.64	3.08	3	1.82	1.75	0.77	0.14	0	44.43
Ave	0.88	1.67	3.56	9.23	17.56	13.89	7.21	4.11	2.97	1.99	1.01	0.68	64.76
SD	1.00	2.29	6.40	12.20	34.72	23.79	6.83	2.45	1.80	1.37	0.97	0.80	78.38

**Simulated Natural River Flow B83B (units – million cubic meters)
WR90 (1920 to 1989) based on regional parameters**

Year	Oct	Nov	Dec	Jan	Feb	Mar	Apr	May	Jun	Jul	Aug	Sep	Sum
1920	0.02	0.01	0.00	0.00	0.03	0.46	0.15	0.00	0.00	0.00	0.00	0.00	0.67
1921	0.00	0.01	1.84	0.61	0.00	0.00	0.00	0.00	0.00	0.00	0.00	0.00	2.46
1922	0.00	0.07	0.02	22.66	25.34	5.99	0.02	0.00	0.00	0.00	0.00	0.00	54.09
1923	0.00	0.00	0.34	0.11	0.00	12.92	4.31	0.00	0.00	0.00	0.00	0.00	17.68
1924	0.00	0.25	0.11	3.61	1.34	36.67	12.21	0.00	0.00	0.00	0.00	0.00	54.18
1925	0.00	0.00	0.00	1.06	1.95	0.54	0.00	0.00	0.00	0.00	0.00	0.00	3.55
1926	0.00	0.00	0.01	0.00	0.00	0.00	0.00	0.00	0.00	0.00	0.00	0.00	0.01
1927	0.07	0.02	0.66	3.90	1.23	0.00	0.00	0.00	0.00	0.00	0.00	0.00	5.88
1928	0.00	0.00	0.08	0.04	1.04	0.36	0.03	0.01	0.00	0.00	0.00	0.00	1.57
1929	0.00	0.10	0.28	0.08	0.31	2.02	0.64	0.00	0.00	0.00	0.00	0.00	3.43
1930	0.00	0.00	19.34	6.45	0.00	0.03	0.01	0.00	0.00	0.00	0.00	0.00	25.83
1931	0.00	0.00	0.00	0.00	0.00	0.12	0.04	0.00	0.00	0.00	0.00	0.00	0.17
1932	0.00	0.00	3.95	6.10	1.59	0.00	0.00	0.00	0.00	0.00	0.00	0.00	11.64
1933	0.00	0.28	0.09	0.12	0.04	0.02	0.01	0.00	0.00	0.00	0.00	0.00	0.55
1934	0.00	0.56	0.43	0.08	0.00	0.00	0.00	0.00	0.00	0.00	0.00	0.00	1.07
1935	0.00	0.00	0.00	1.56	0.52	0.14	0.05	0.00	0.00	0.00	0.00	0.00	2.28
1936	0.00	0.00	0.02	0.04	3.12	1.04	0.00	0.00	0.00	0.00	0.00	0.00	4.23
1937	0.00	0.00	0.12	0.35	0.10	0.00	1.05	0.35	0.00	0.00	0.00	0.03	1.99
1938	0.16	0.05	2.19	0.86	34.50	11.49	0.00	0.00	0.00	0.00	0.00	0.00	49.25
1939	0.00	1.77	1.09	0.17	0.00	0.24	0.13	0.02	0.00	0.00	0.00	0.00	3.41
1940	0.00	0.08	1.29	0.42	0.00	0.00	0.10	0.03	0.00	0.00	0.00	0.00	1.94
1941	0.00	0.00	1.33	1.00	0.19	3.42	1.14	0.00	0.00	0.00	0.00	0.00	7.08
1942	0.00	0.00	0.00	0.00	0.00	0.20	0.60	0.18	0.00	0.00	0.00	0.00	0.98
1943	0.00	0.00	0.00	0.00	9.65	3.22	0.00	0.00	0.00	0.00	0.00	0.00	12.87
1944	0.00	0.00	0.00	0.31	0.10	0.00	0.00	0.00	0.00	0.00	0.00	0.00	0.41
1945	0.00	0.00	0.00	11.86	4.48	0.18	0.00	0.00	0.00	0.00	0.00	0.00	16.52
1946	0.00	0.00	0.00	0.00	0.01	0.00	0.00	0.00	0.00	0.00	0.00	0.00	0.02
1947	0.00	0.01	0.84	1.56	0.43	16.81	5.60	0.00	0.00	0.00	0.00	0.00	25.25
1948	0.00	0.00	0.00	4.99	1.66	0.00	0.00	0.00	0.00	0.00	0.00	0.00	6.66
1949	0.00	0.22	0.14	0.02	0.12	0.88	0.28	0.00	0.00	0.00	0.00	0.00	1.67
1950	0.00	0.00	0.88	0.29	0.00	0.00	0.00	0.00	0.00	0.00	0.00	0.00	1.17
1951	0.00	0.00	0.00	0.10	0.03	0.00	0.00	0.00	0.00	0.00	0.00	0.00	0.13
1952	0.00	0.02	0.35	0.45	2.31	0.74	0.00	0.00	0.00	0.00	0.00	0.00	3.88
1953	0.00	0.36	0.12	0.10	1.55	0.50	0.00	0.00	0.00	0.00	0.00	0.00	2.62
1954	0.00	0.09	0.27	0.60	1.07	0.32	0.01	0.00	0.00	0.00	0.00	0.00	2.36
1955	0.00	0.23	0.25	0.06	38.80	12.93	0.00	0.00	0.00	0.00	0.00	0.00	52.27
1956	0.00	0.00	0.24	0.75	0.89	0.25	0.01	0.00	0.00	0.00	0.00	0.00	2.14
1957	0.03	0.01	0.01	67.00	22.33	0.00	0.00	0.00	0.00	0.00	0.00	0.00	89.39
1958	0.00	0.37	1.09	0.55	0.48	0.14	0.00	0.00	0.00	0.00	0.00	0.00	2.63
1959	0.00	0.00	0.00	0.00	8.85	2.95	0.03	0.01	0.00	0.00	0.00	0.00	11.84
1960	0.00	0.03	1.19	0.39	0.48	0.16	0.00	0.00	0.00	0.00	0.00	0.00	2.26
1961	0.00	0.00	0.55	0.30	0.04	0.00	0.00	0.00	0.00	0.00	0.00	0.00	0.89
1962	0.00	2.29	1.61	0.28	0.00	0.00	0.00	0.00	0.00	0.00	0.00	0.00	4.18
1963	0.00	0.00	0.00	0.00	0.00	0.00	0.00	0.00	0.00	0.00	0.00	0.00	0.00
1964	0.01	0.00	1.40	0.51	0.01	0.00	0.00	0.00	0.00	0.00	0.00	0.00	1.94
1965	0.00	0.00	0.00	0.31	0.23	0.04	0.00	0.00	0.00	0.00	0.00	0.00	0.58
1966	0.00	0.00	0.00	1.29	1.12	0.23	0.02	0.01	0.00	0.00	0.00	0.00	2.68
1967	0.00	0.00	0.00	0.00	0.05	0.02	0.00	0.00	0.00	0.00	0.00	0.00	0.07
1968	0.00	0.02	3.43	1.14	0.00	2.09	0.70	0.00	0.00	0.40	0.00	0.00	7.38
1969	0.57	0.19	0.00	0.00	0.00	0.00	0.00	0.00	0.00	0.00	0.00	0.00	0.76
1970	0.00	0.00	0.10	1.77	0.58	0.00	0.00	0.00	0.00	0.00	0.00	0.00	2.45
1971	0.00	0.02	0.04	2.79	1.52	2.64	0.81	0.00	0.00	0.00	0.00	0.00	7.84
1972	0.00	0.00	0.00	0.22	0.07	0.00	0.00	0.00	0.00	0.00	0.00	0.72	1.01
1973	0.24	0.00	1.74	0.73	3.10	1.02	0.00	0.00	0.00	0.00	0.00	0.00	6.84
1974	0.00	0.33	0.11	1.37	2.00	0.51	0.00	0.00	0.00	0.00	0.00	0.00	4.33
1975	0.00	0.00	0.78	2.36	1.68	0.49	0.05	0.00	0.00	0.00	0.00	0.00	5.37
1976	0.00	0.00	0.00	0.48	7.07	2.51	0.07	0.00	0.00	0.00	0.00	0.00	10.13
1977	0.00	0.02	0.31	0.41	0.29	1.51	0.48	0.00	0.00	0.00	0.00	0.00	3.04
1978	0.00	0.05	0.12	0.04	0.00	0.00	0.00	0.00	0.00	0.00	0.00	0.00	0.21
1979	0.00	0.00	0.53	0.25	11.47	3.81	0.00	0.00	0.00	0.00	0.00	0.02	16.08
1980	0.01	0.13	0.92	14.23	4.74	0.36	0.11	0.00	0.00	0.00	0.00	0.00	20.50
1981	0.00	0.08	0.03	0.00	0.00	0.00	0.00	0.00	0.00	0.00	0.00	0.00	0.11
1982	0.00	0.00	0.00	0.00	0.00	0.00	0.00	0.00	0.00	0.00	0.00	0.00	0.00
1983	0.00	0.11	0.04	0.00	0.00	0.04	0.01	0.00	0.00	0.00	0.00	0.00	0.20
1984	0.11	0.05	0.10	4.58	1.65	0.05	0.00	0.00	0.00	0.00	0.00	0.00	6.55
1985	0.17	0.06	0.02	0.01	0.00	0.00	0.05	0.02	0.00	0.00	0.00	0.00	0.32
1986	0.00	0.00	0.09	0.11	0.03	0.00	0.00	0.00	0.00	0.00	0.00	0.00	0.23
1987	0.00	0.00	4.37	1.46	0.25	0.12	0.01	0.00	0.00	0.30	0.00	0.00	6.22
1988	0.01	0.00	0.21	0.07	0.49	0.16	0.00	0.00	0.00	0.00	0.00	0.00	0.95
1989	0.01	0.47	0.28	0.59	0.19	0.01	0.00	0.00	0.00	0.00	0.00	0.00	1.55
Ave	0.02	0.12	0.79	2.48	2.87	1.86	0.41	0.01	0.00	0.00	0.00	0.01	8.58
SD	0.08	0.35	2.42	8.60	7.33	5.33	1.67	0.05	0.00	0.00	0.00	0.09	15.96

**Simulated Natural River Flow B83B (units – million cubic meters) (LETRQ4.ANS)
This Study September 2004 (1920 to 2001) Based on updated Calibration, WRSM2000**

Year	Oct	Nov	Dec	Jan	Feb	Mar	Apr	May	Jun	Jul	Aug	Sep	Sum
1920.00	0.00	0.00	0.00	0.00	0.00	0.12	0.04	0.00	0.00	0.00	0.00	0.00	0.15
1921.00	0.00	0.00	0.91	0.30	0.00	0.00	0.00	0.00	0.00	0.00	0.00	0.00	1.21
1922.00	0.00	0.00	0.00	18.97	7.89	0.52	0.00	0.00	0.00	0.00	0.00	0.00	27.39
1923.00	0.00	0.00	0.07	0.02	0.00	9.90	3.30	0.00	0.00	0.00	0.00	0.00	13.30
1924.00	0.00	0.04	0.01	2.16	0.73	10.52	3.51	0.00	0.00	0.00	0.00	0.00	16.97
1925.00	0.00	0.00	0.00	0.43	0.89	0.25	0.00	0.00	0.00	0.00	0.00	0.00	1.57
1926.00	0.00	0.00	0.00	0.00	0.00	0.00	0.00	0.00	0.00	0.00	0.00	0.00	0.00
1927.00	0.00	0.00	0.21	2.28	0.74	0.00	0.00	0.00	0.00	0.00	0.00	0.00	3.23
1928.00	0.00	0.00	0.00	0.00	0.42	0.14	0.00	0.00	0.00	0.00	0.00	0.00	0.56
1929.00	0.00	0.00	0.04	0.01	0.06	0.98	0.32	0.00	0.00	0.00	0.00	0.00	1.42
1930.00	0.00	0.00	15.82	5.27	0.00	0.00	0.00	0.00	0.00	0.00	0.00	0.00	21.09
1931.00	0.00	0.00	0.00	0.00	0.00	0.01	0.00	0.00	0.00	0.00	0.00	0.00	0.01
1932.00	0.00	0.00	2.42	3.86	1.02	0.00	0.00	0.00	0.00	0.00	0.00	0.00	7.30
1933.00	0.00	0.05	0.02	0.01	0.00	0.00	0.00	0.00	0.00	0.00	0.00	0.00	0.07
1934.00	0.00	0.16	0.09	0.01	0.00	0.00	0.00	0.00	0.00	0.00	0.00	0.00	0.27
1935.00	0.00	0.00	0.00	0.73	0.24	0.01	0.00	0.00	0.00	0.00	0.00	0.00	0.99
1936.00	0.00	0.00	0.00	0.00	1.79	0.60	0.00	0.00	0.00	0.00	0.00	0.00	2.39
1937.00	0.00	0.00	0.01	0.06	0.02	0.00	0.42	0.14	0.00	0.00	0.00	0.00	0.65
1938.00	0.01	0.00	1.14	0.39	13.75	4.58	0.00	0.00	0.00	0.00	0.00	0.00	19.88
1939.00	0.00	0.86	0.42	0.04	0.00	0.04	0.01	0.00	0.00	0.00	0.00	0.00	1.38
1940.00	0.00	0.00	0.55	0.18	0.00	0.00	0.01	0.00	0.00	0.00	0.00	0.00	0.74
1941.00	0.00	0.00	0.59	0.36	0.05	2.02	0.67	0.00	0.00	0.00	0.00	0.00	3.69
1942.00	0.00	0.00	0.00	0.00	0.00	0.03	0.16	0.05	0.00	0.00	0.00	0.00	0.24
1943.00	0.00	0.00	0.00	0.00	7.06	2.35	0.00	0.00	0.00	0.00	0.00	0.00	9.41
1944.00	0.00	0.00	0.00	0.06	0.02	0.00	0.00	0.00	0.00	0.00	0.00	0.00	0.08
1945.00	0.00	0.00	0.00	8.96	3.14	0.05	0.00	0.00	0.00	0.00	0.00	0.00	12.15
1946.00	0.00	0.00	0.00	0.00	0.00	0.00	0.00	0.00	0.00	0.00	0.00	0.00	0.00
1947.00	0.00	0.00	0.30	0.66	0.19	6.93	2.31	0.00	0.00	0.00	0.00	0.00	10.38
1948.00	0.00	0.00	0.00	3.22	1.07	0.00	0.00	0.00	0.00	0.00	0.00	0.00	4.30
1949.00	0.00	0.03	0.01	0.00	0.01	0.31	0.10	0.00	0.00	0.00	0.00	0.00	0.46
1950.00	0.00	0.00	0.33	0.11	0.00	0.00	0.00	0.00	0.00	0.00	0.00	0.00	0.43
1951.00	0.00	0.00	0.00	0.00	0.00	0.00	0.00	0.00	0.00	0.00	0.00	0.00	0.01
1952.00	0.00	0.00	0.07	0.10	1.17	0.38	0.00	0.00	0.00	0.00	0.00	0.00	1.72
1953.00	0.00	0.08	0.03	0.00	0.70	0.23	0.00	0.00	0.00	0.00	0.00	0.00	1.04
1954.00	0.00	0.00	0.04	0.16	0.38	0.11	0.00	0.00	0.00	0.00	0.00	0.00	0.69
1955.00	0.00	0.03	0.03	0.01	30.37	10.12	0.00	0.00	0.00	0.00	0.00	0.00	40.57
1956.00	0.00	0.00	0.04	0.23	0.29	0.07	0.00	0.00	0.00	0.00	0.00	0.00	0.63
1957.00	0.00	0.00	0.00	57.03	19.01	0.00	0.00	0.00	0.00	0.00	0.00	0.00	76.04
1958.00	0.00	0.08	0.40	0.16	0.11	0.03	0.00	0.00	0.00	0.00	0.00	0.00	0.78
1959.00	0.00	0.00	0.00	0.00	6.38	2.13	0.00	0.00	0.00	0.00	0.00	0.00	8.50
1960.00	0.00	0.00	0.50	0.17	0.13	0.04	0.00	0.00	0.00	0.00	0.00	0.00	0.83
1961.00	0.00	0.00	0.16	0.06	0.00	0.00	0.00	0.00	0.00	0.00	0.00	0.00	0.22
1962.00	0.00	1.21	0.71	0.10	0.00	0.00	0.00	0.00	0.00	0.00	0.00	0.00	2.02
1963.00	0.00	0.00	0.00	0.00	0.00	0.00	0.00	0.00	0.00	0.00	0.00	0.00	0.00
1964.00	0.00	0.00	0.63	0.21	0.00	0.00	0.00	0.00	0.00	0.00	0.00	0.00	0.84
1965.00	0.00	0.00	0.00	0.06	0.03	0.00	0.00	0.00	0.00	0.00	0.00	0.00	0.09
1966.00	0.00	0.00	0.00	0.56	0.41	0.08	0.00	0.00	0.00	0.00	0.00	0.00	1.05
1967.00	0.00	0.00	0.00	0.00	0.00	0.00	0.00	0.00	0.00	0.00	0.00	0.00	0.00
1968.00	0.00	0.00	2.02	0.67	0.00	1.08	0.36	0.00	0.00	0.00	0.00	0.00	4.13
1969.00	0.17	0.06	0.00	0.00	0.00	0.00	0.00	0.00	0.00	0.00	0.00	0.00	0.23
1970.00	0.00	0.00	0.00	0.84	0.28	0.00	0.00	0.00	0.00	0.00	0.00	0.00	1.13
1971.00	0.00	0.00	0.00	1.56	0.70	0.48	0.14	0.00	0.00	0.00	0.00	0.00	2.88
1972.00	0.00	0.00	0.00	0.03	0.01	0.00	0.00	0.00	0.00	0.00	0.00	0.24	0.28
1973.00	0.08	0.00	0.84	0.30	1.75	0.58	0.00	0.00	0.00	0.00	0.00	0.00	3.56
1974.00	0.00	0.07	0.02	0.61	0.92	0.24	0.00	0.00	0.00	0.00	0.00	0.00	1.86
1975.00	0.00	0.00	0.27	1.18	0.74	0.14	0.01	0.00	0.00	0.00	0.00	0.00	2.34
1976.00	0.00	0.00	0.00	0.13	4.81	1.62	0.01	0.00	0.00	0.00	0.00	0.00	6.56
1977.00	0.00	0.00	0.06	0.08	0.04	0.67	0.22	0.00	0.00	0.00	0.00	0.00	1.07
1978.00	0.00	0.00	0.01	0.00	0.00	0.00	0.00	0.00	0.00	0.00	0.00	0.00	0.01
1979.00	0.00	0.00	0.15	0.05	5.16	1.72	0.00	0.00	0.00	0.00	0.00	0.00	7.09
1980.00	0.00	0.01	0.33	5.83	1.91	0.07	0.02	0.00	0.00	0.00	0.00	0.00	8.17
1981.00	0.00	0.00	0.00	0.00	0.00	0.00	0.00	0.00	0.00	0.00	0.00	0.00	0.00
1982.00	0.00	0.00	0.00	0.00	0.00	0.00	0.00	0.00	0.00	0.00	0.00	0.00	0.00
1983.00	0.00	0.01	0.00	0.00	0.00	0.00	0.00	0.00	0.00	0.00	0.00	0.00	0.01
1984.00	0.01	0.00	0.00	2.88	0.97	0.00	0.00	0.00	0.00	0.00	0.00	0.00	3.86
1985.00	0.02	0.01	0.00	0.00	0.00	0.00	0.00	0.00	0.00	0.00	0.00	0.00	0.02
1986.00	0.00	0.00	0.00	0.00	0.00	0.00	0.00	0.00	0.00	0.00	0.00	0.00	0.01
1987.00	0.00	0.00	2.74	0.91	0.04	0.01	0.00	0.00	0.00	0.00	0.00	0.00	3.70
1988.00	0.00	0.00	0.03	0.01	0.13	0.04	0.00	0.00	0.00	0.00	0.00	0.00	0.22
1989.00	0.00	0.12	0.05	0.16	0.05	0.00	0.00	0.00	0.00	0.00	0.00	0.00	0.38
1990.00	0.00	0.00	0.15	0.12	0.02	0.00	0.00	0.00	0.00	0.00	0.00	0.00	0.30
1991.00	0.00	0.00	0.00	0.00	0.00	0.00	0.00	0.00	0.00	0.00	0.00	0.00	0.00
1992.00	0.00	0.00	0.89	0.30	0.00	0.00	0.00	0.00	0.00	0.00	0.00	0.00	1.18
1993.00	0.00	0.02	0.01	0.00	0.00	0.00	0.00	0.00	0.00	0.00	0.00	0.00	0.03
1994.00	0.00	0.00	0.00	0.24	0.08	0.00	0.00	0.00	0.00	0.00	0.00	0.00	0.33
1995.00	0.00	0.00	0.00	1.20	5.59	1.73	0.00	0.00	0.00	0.00	0.00	0.00	8.51
1996.00	0.00	0.00	0.00	0.33	0.13	0.01	0.00	0.00	0.00	0.00	0.00	0.00	0.46
1997.00	0.00	0.15	0.05	0.02	0.01	0.00	0.00	0.00	0.00	0.00	0.00	0.00	0.23
1998.00	0.00	0.00	2.19	1.08	0.31	0.07	0.00	0.00	0.00	0.00	0.00	0.00	3.65
1999.00	0.00	0.01	0.02	1.49	59.03	20.35	0.28	0.00	0.00	0.00	0.00	0.00	81.17
2000.00	0.00	0.00	0.00	0.00	3.17	1.07	0.00	0.00	0.00	0.00	0.00	0.00	4.25
2001.00	0.00	0.32	0.11	0.00	0.00	0.00	0.00	0.00	0.00	0.00	0.00	0.00	0.42
Ave	0.00	0.04	0.43	1.55	2.24	1.01	0.15	0.00	0.00	0.00	0.00	0.00	5.42
SD	0.02	0.17	1.80	6.68	7.71	3.02	0.59	0.02	0.00	0.00	0.00	0.03	13.40

APPENDIX B

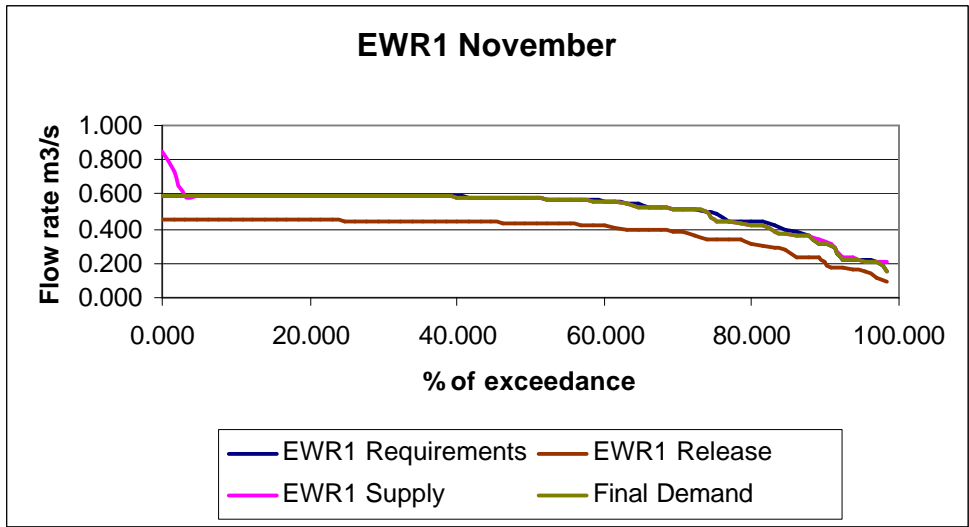
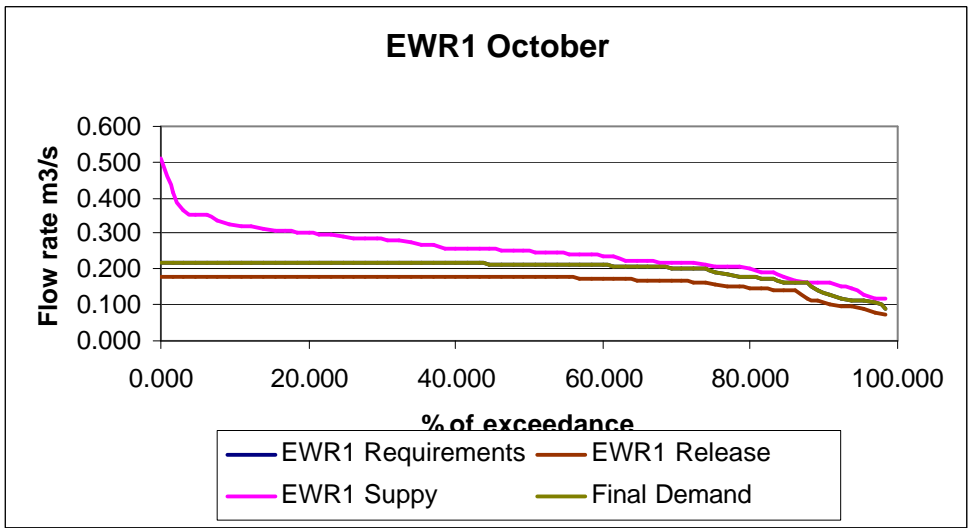

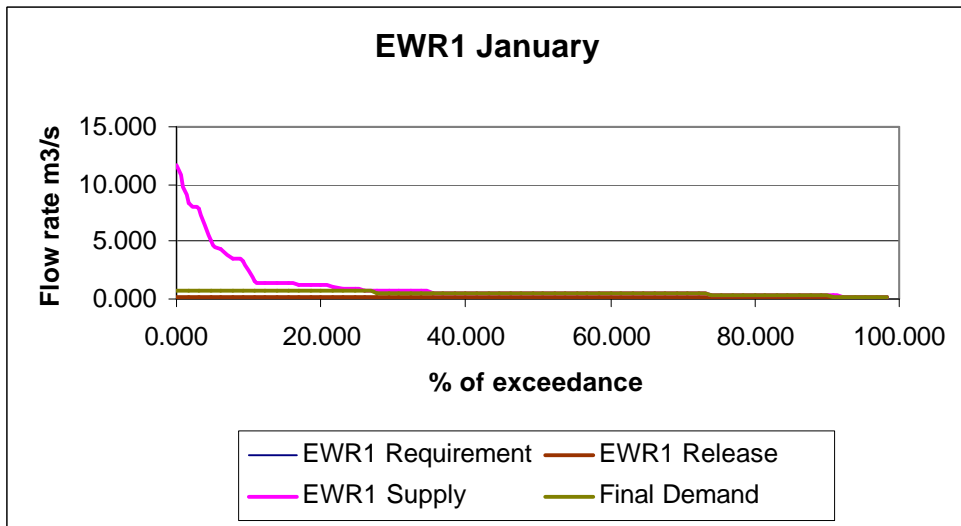
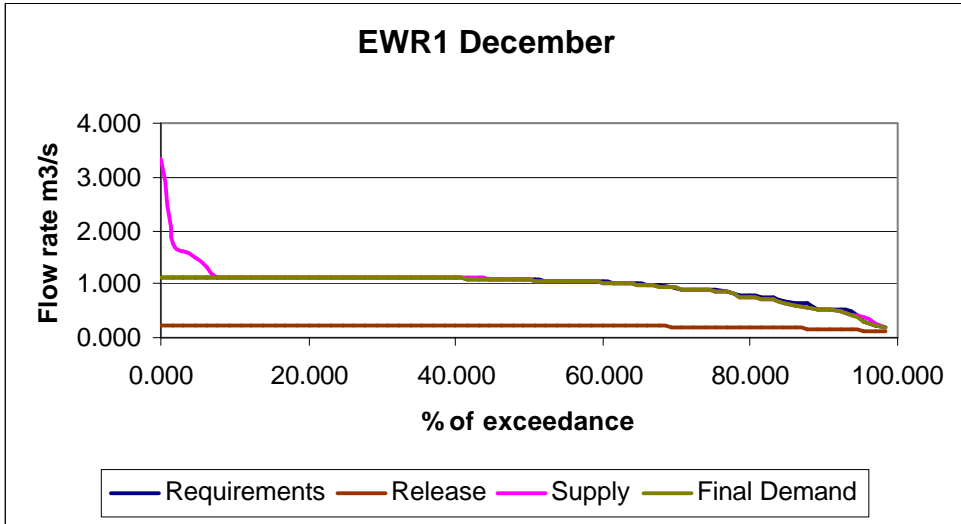

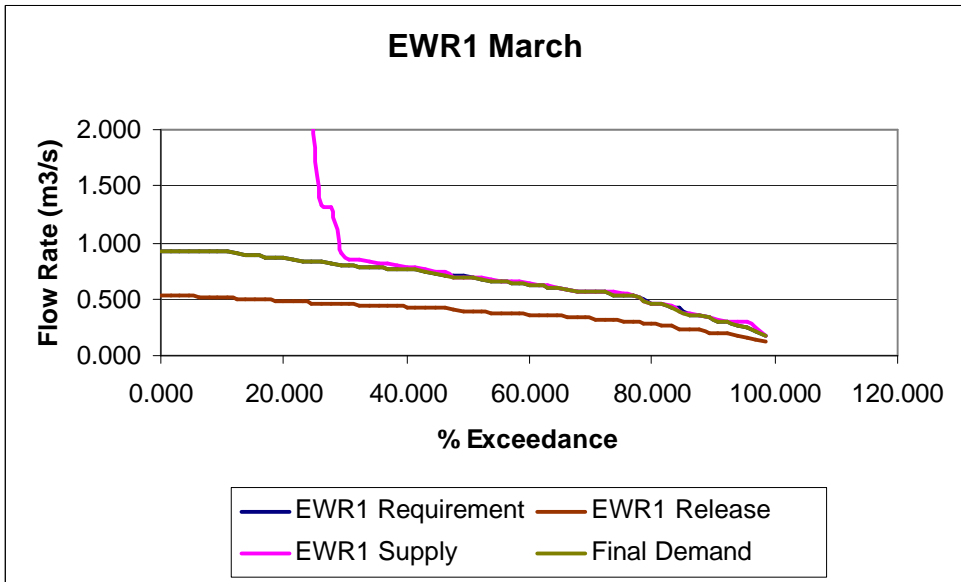
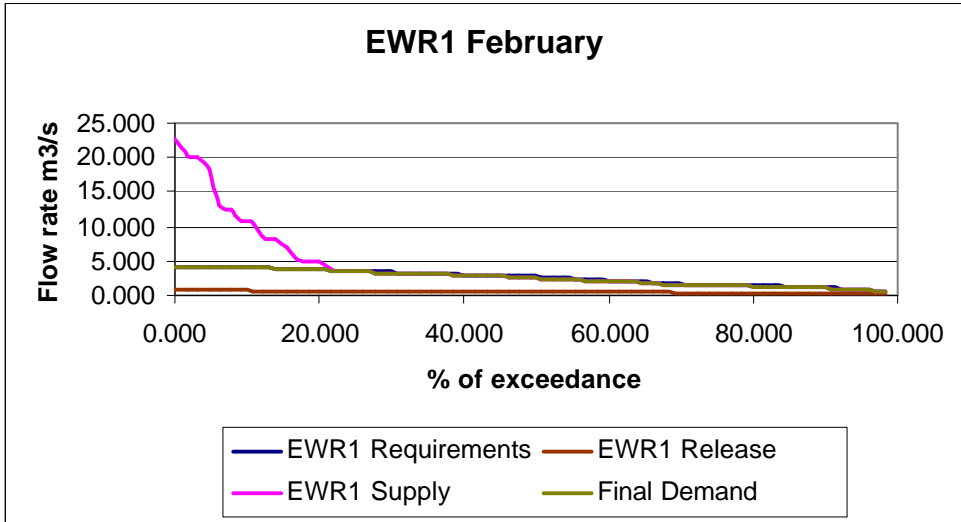

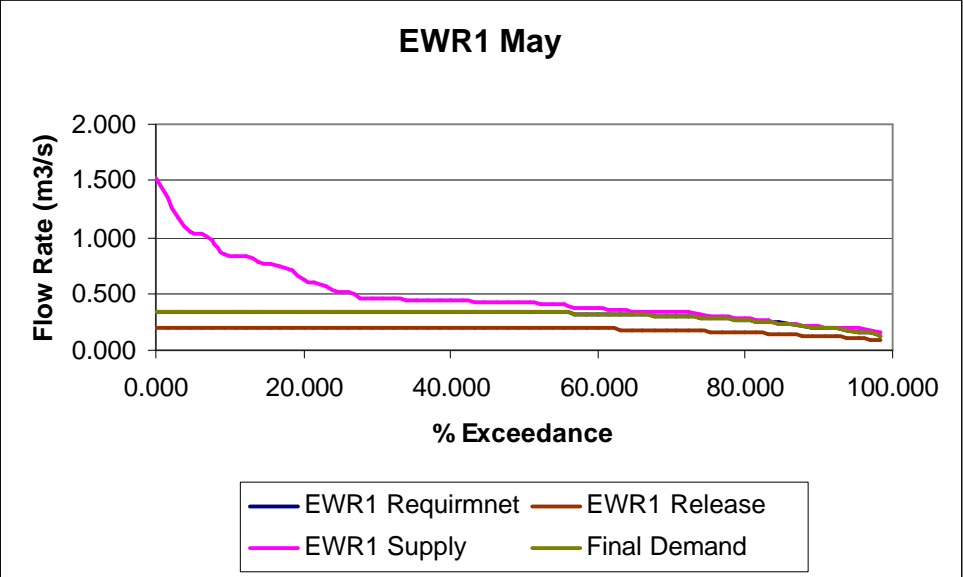
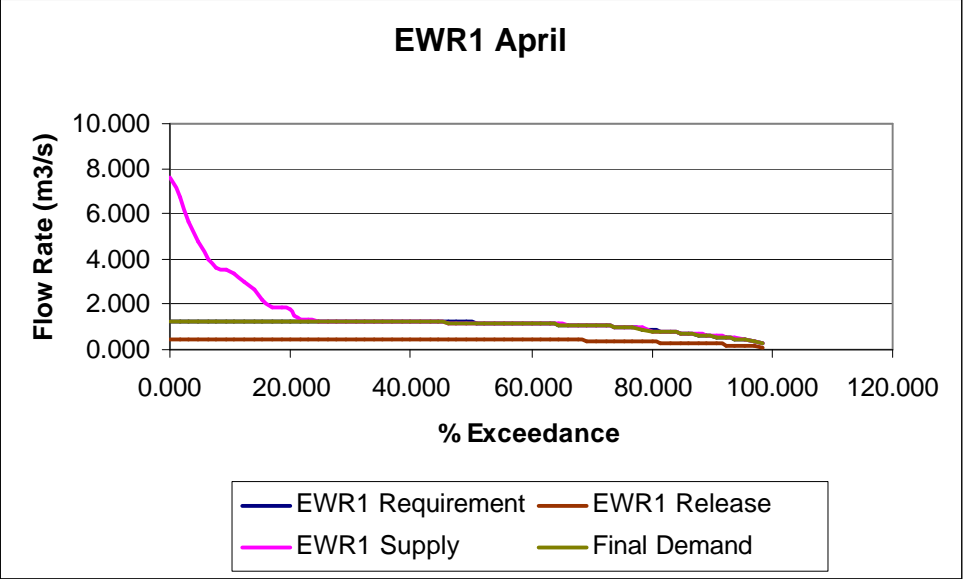

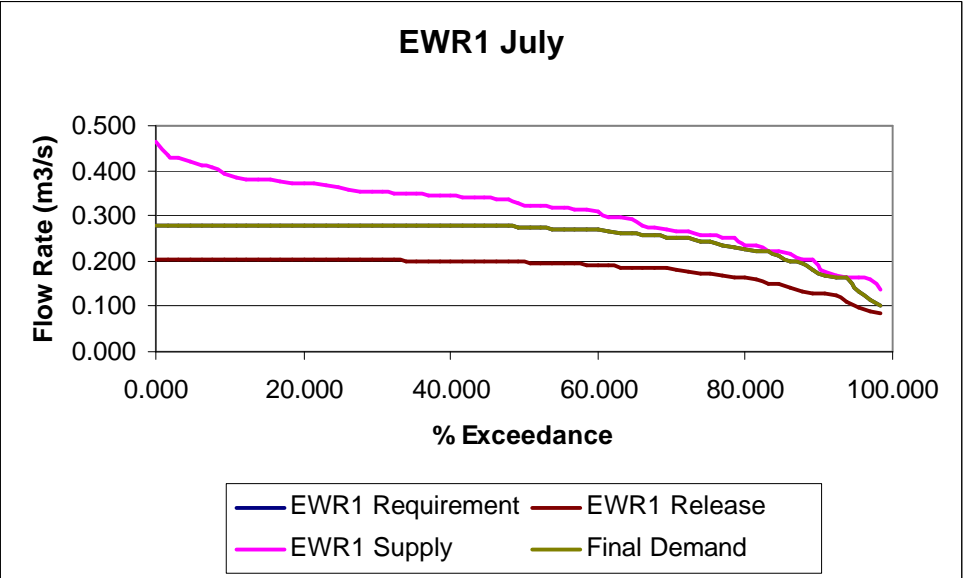
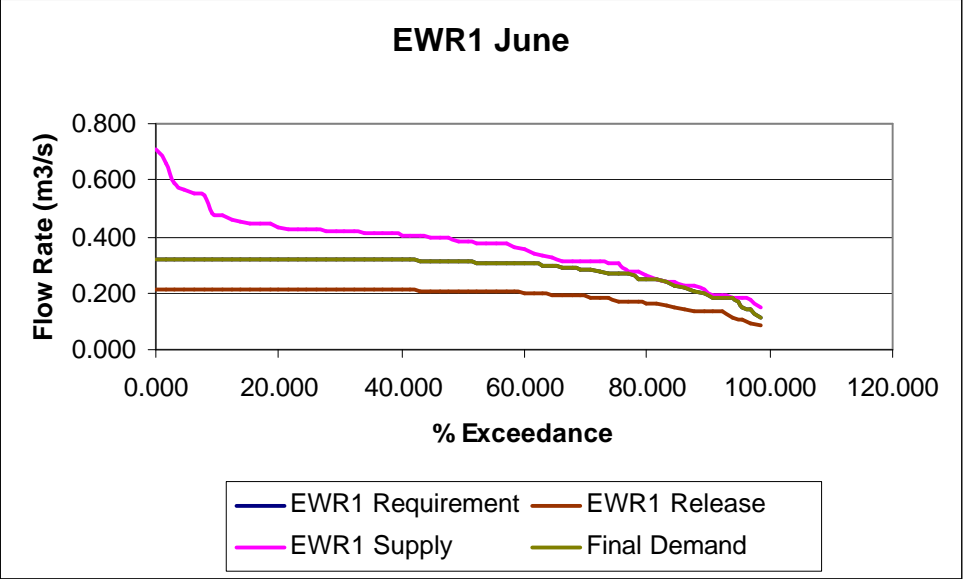

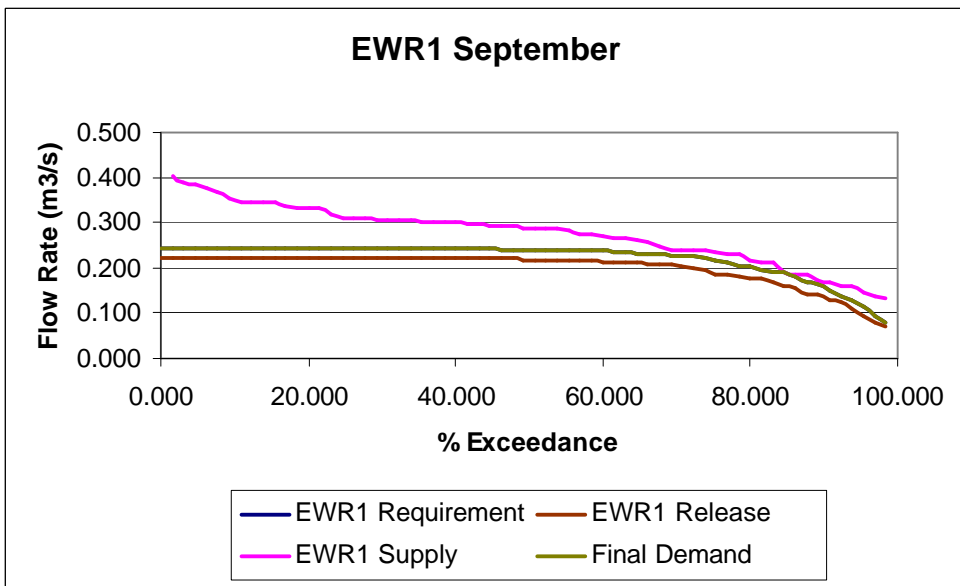
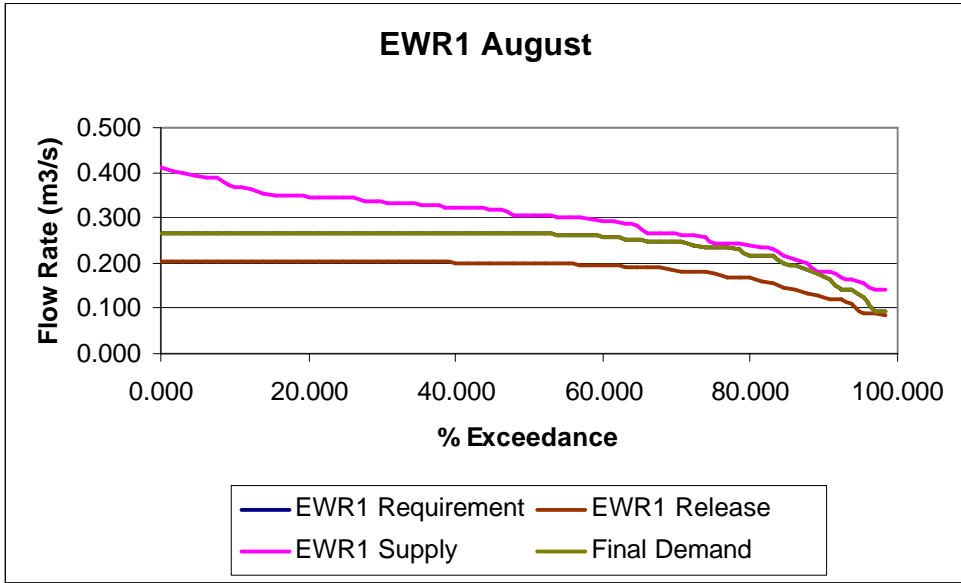

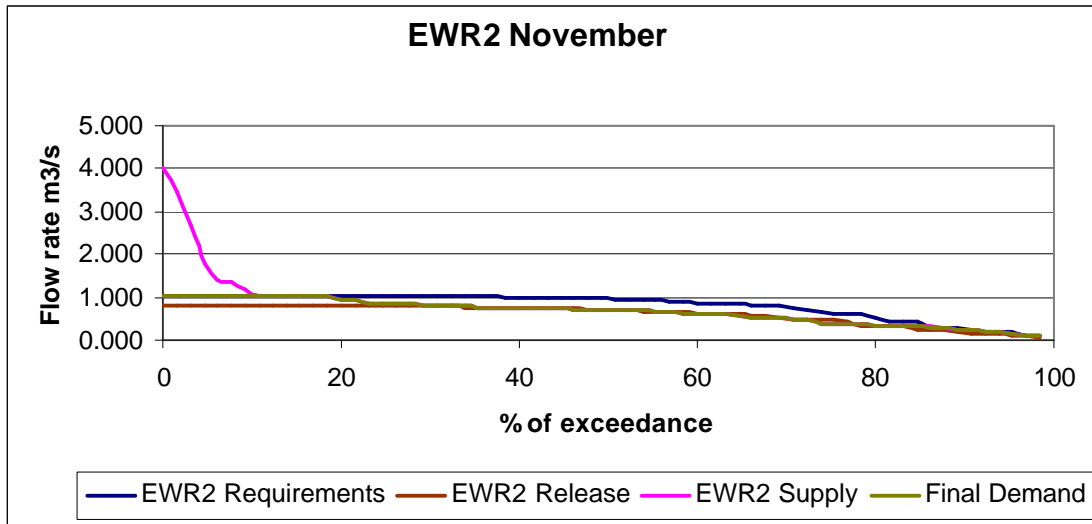
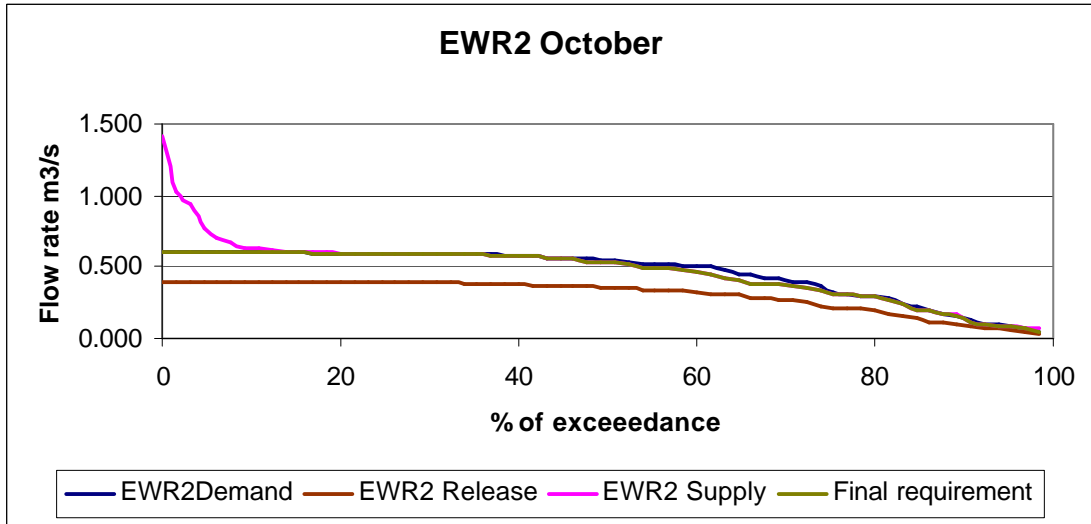

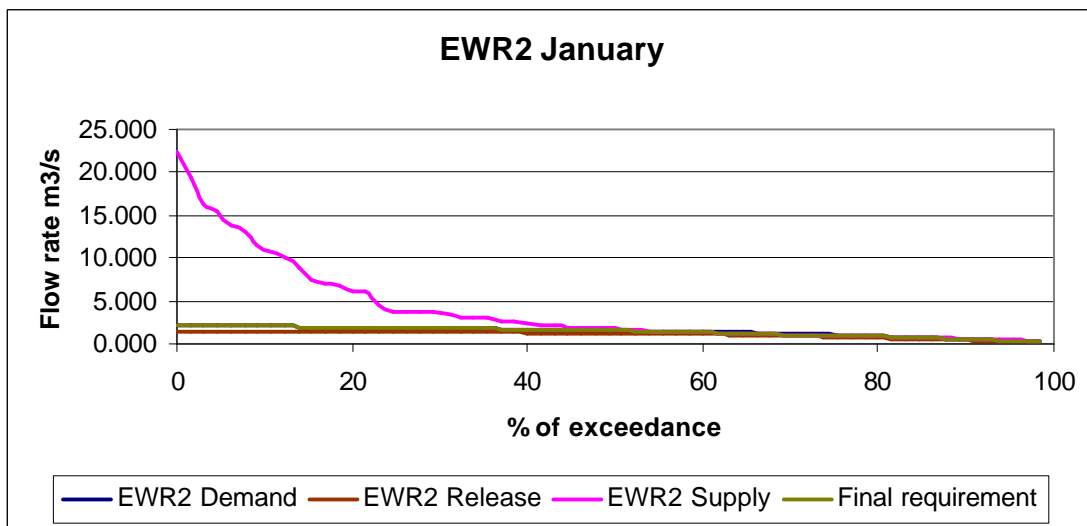
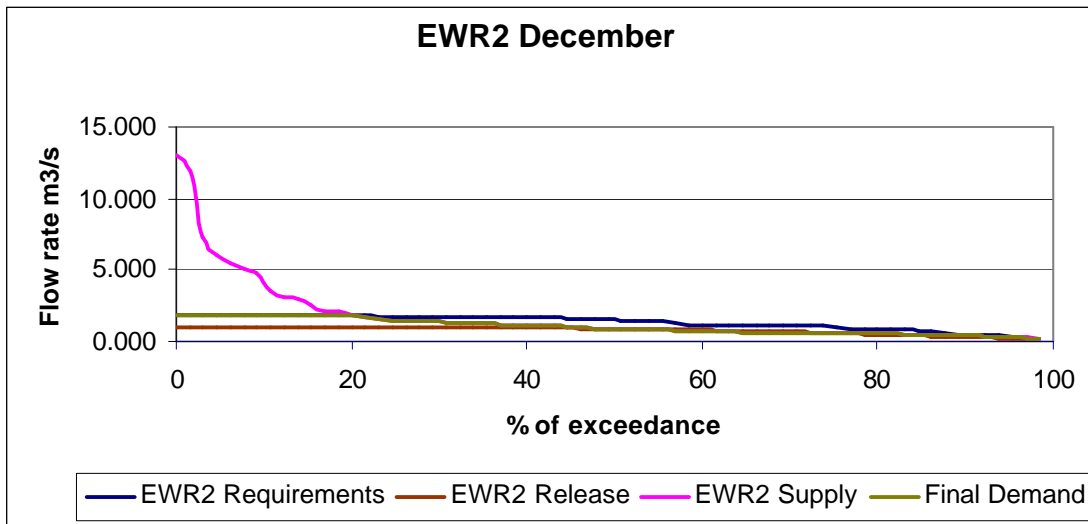

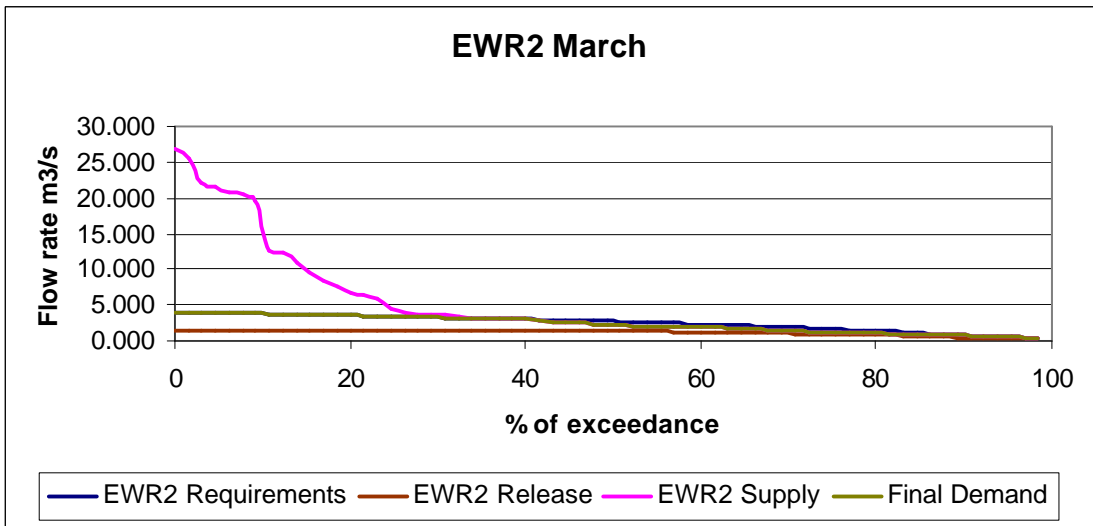
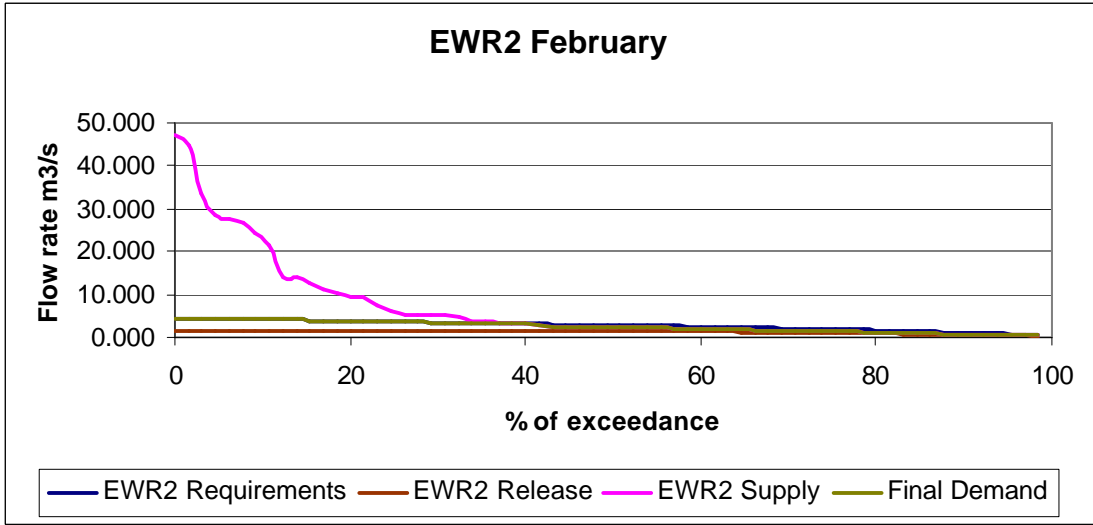

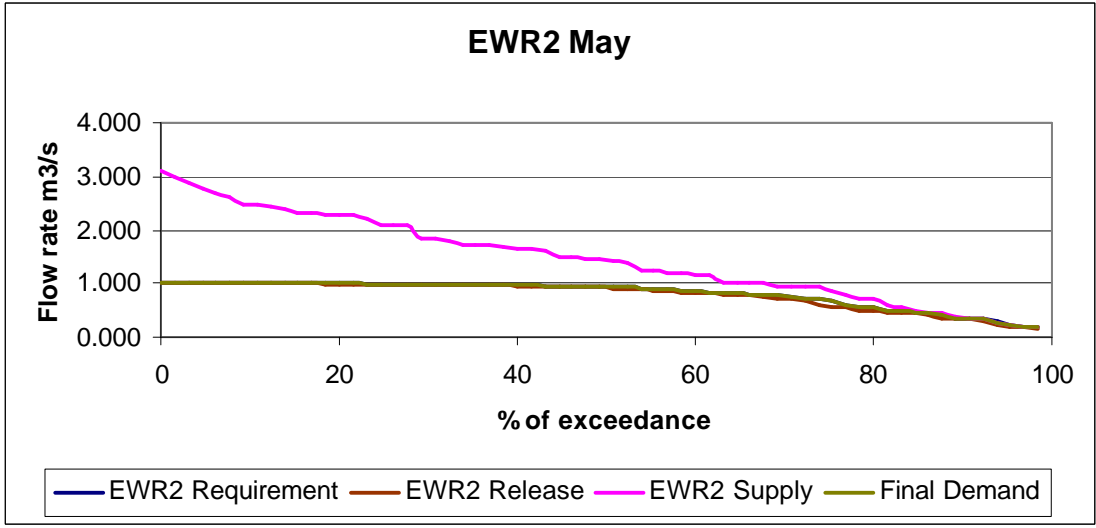
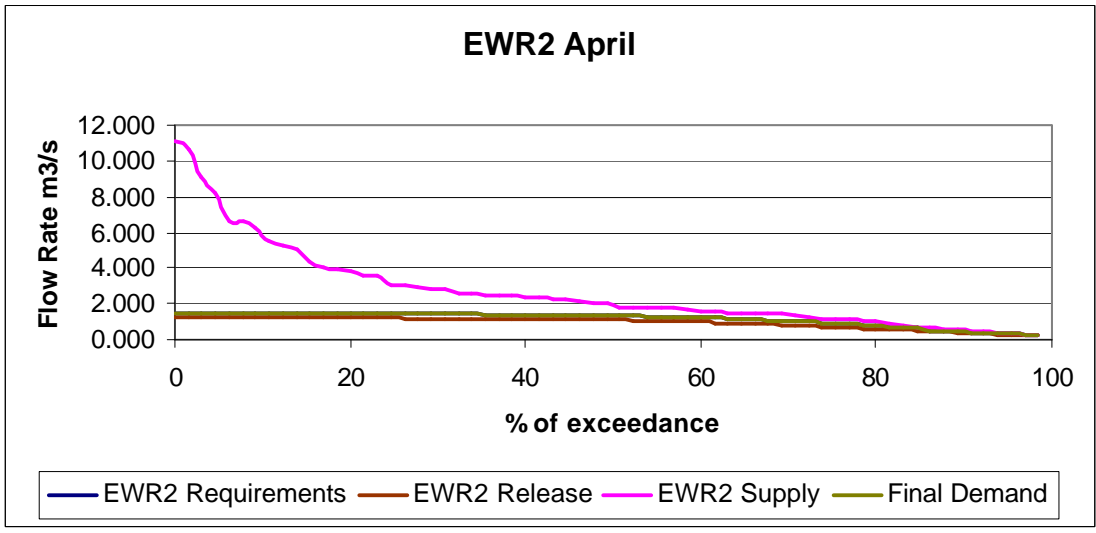

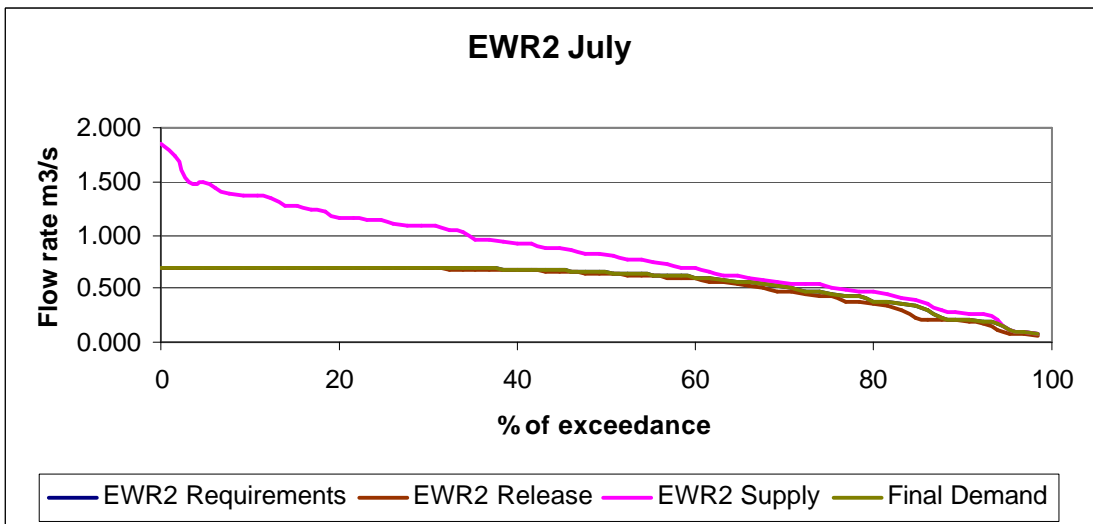
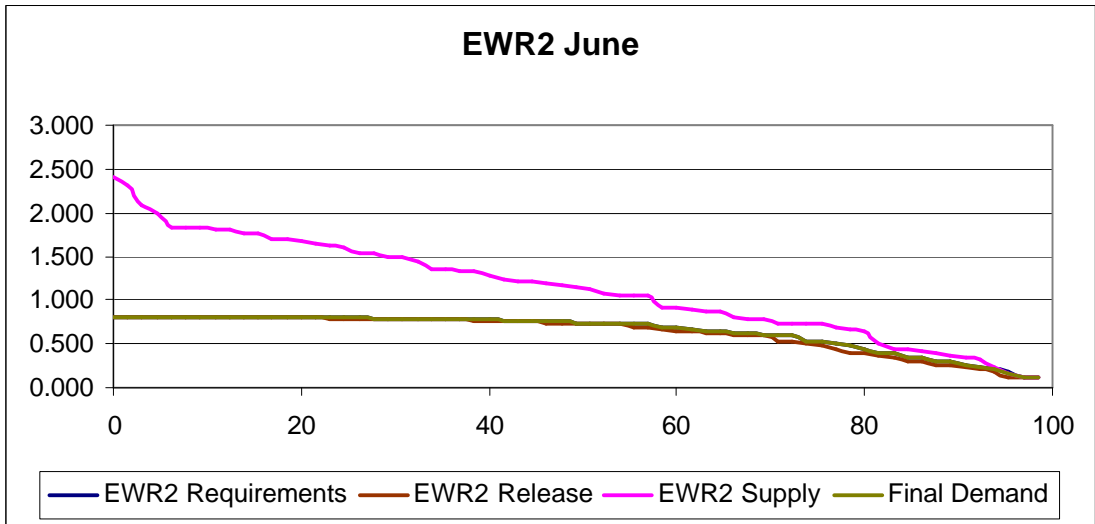

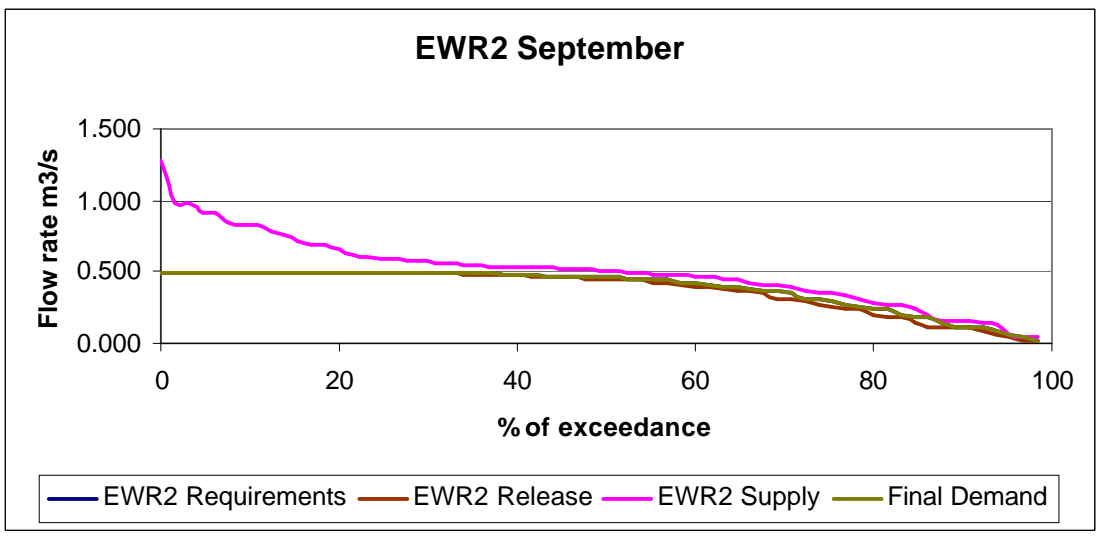
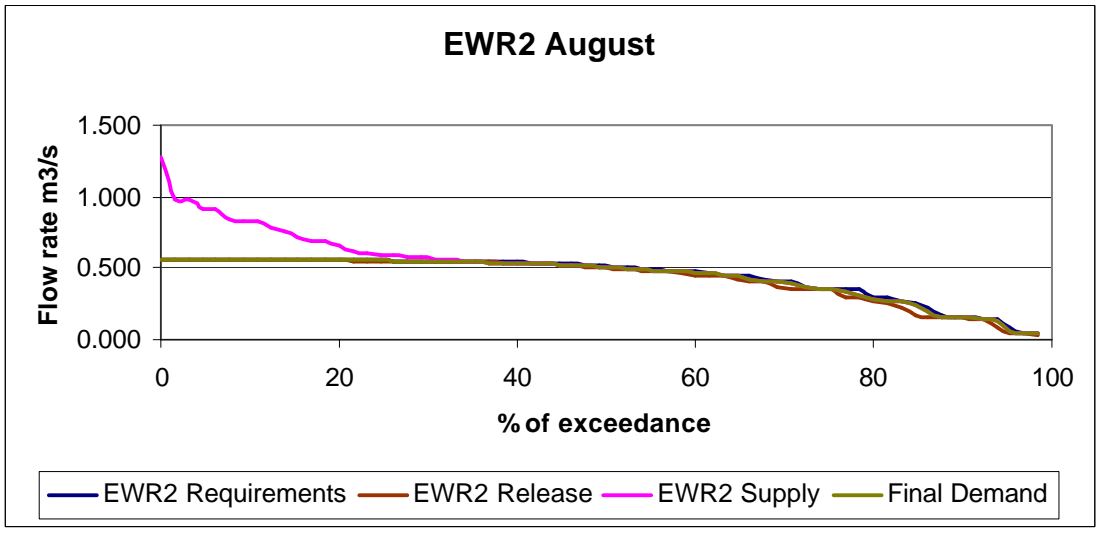

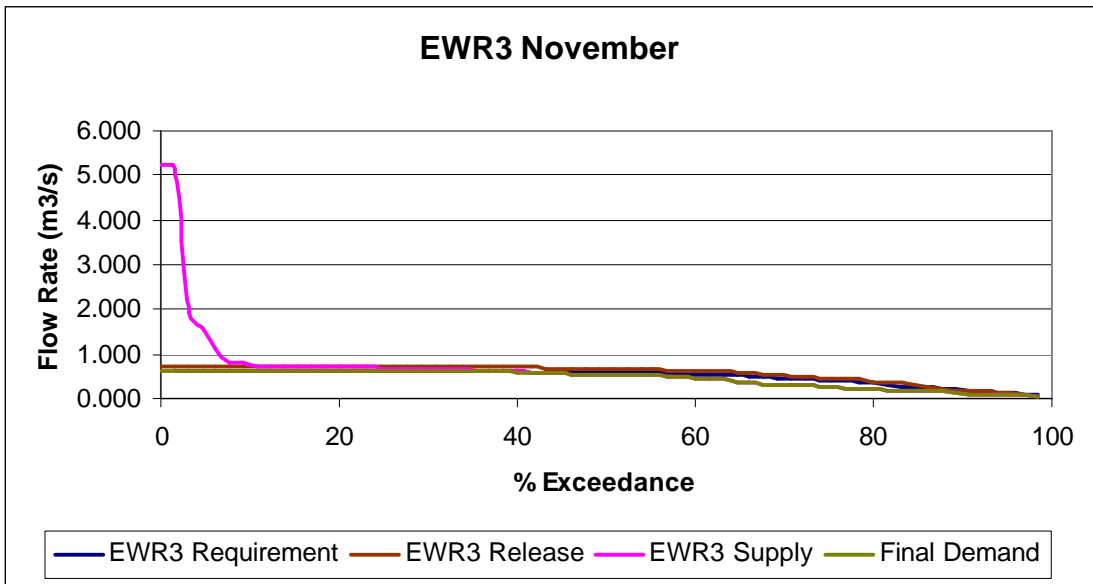
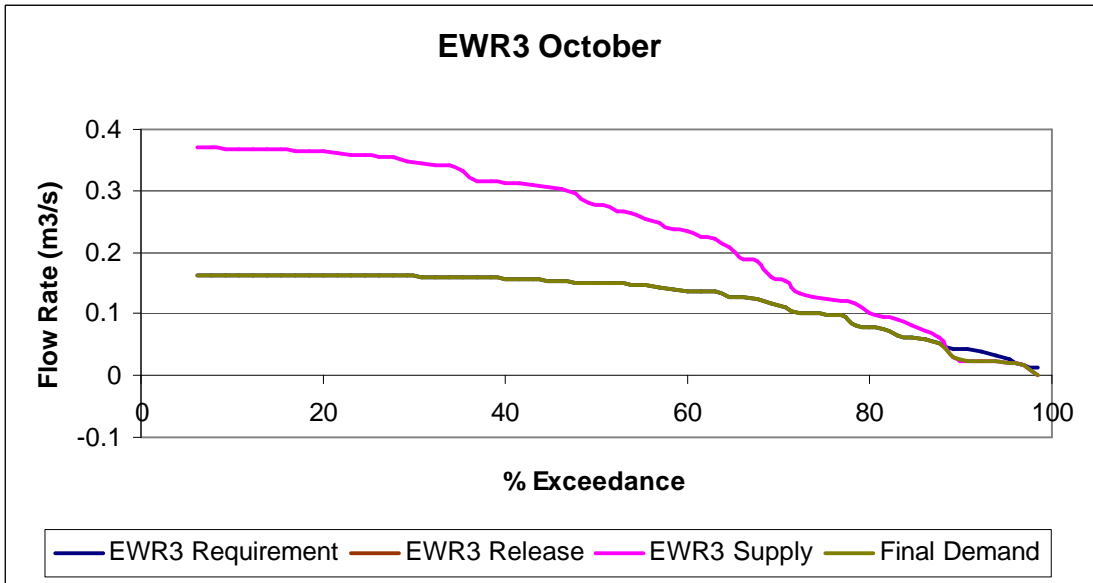

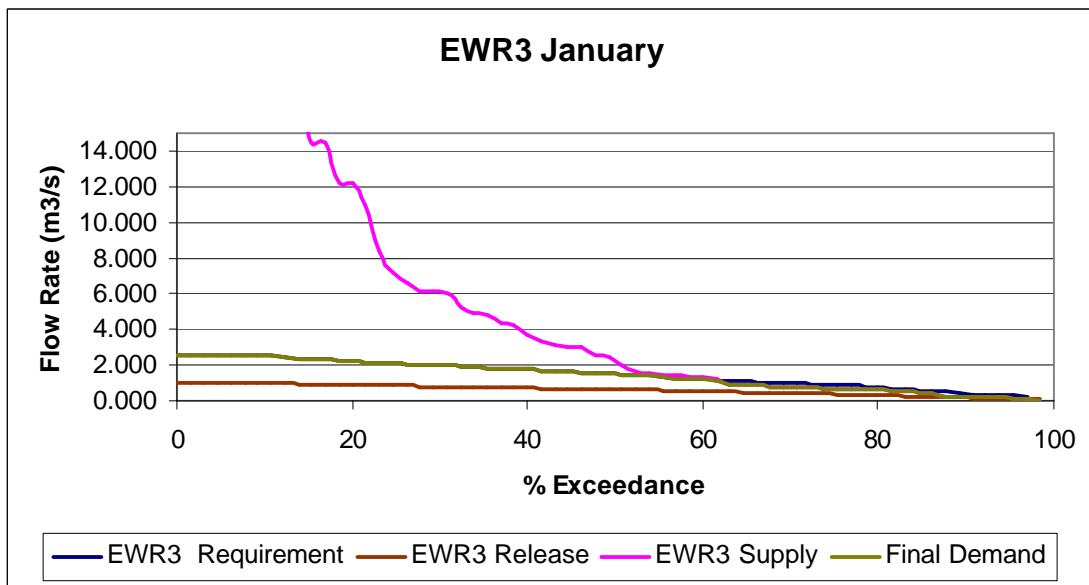
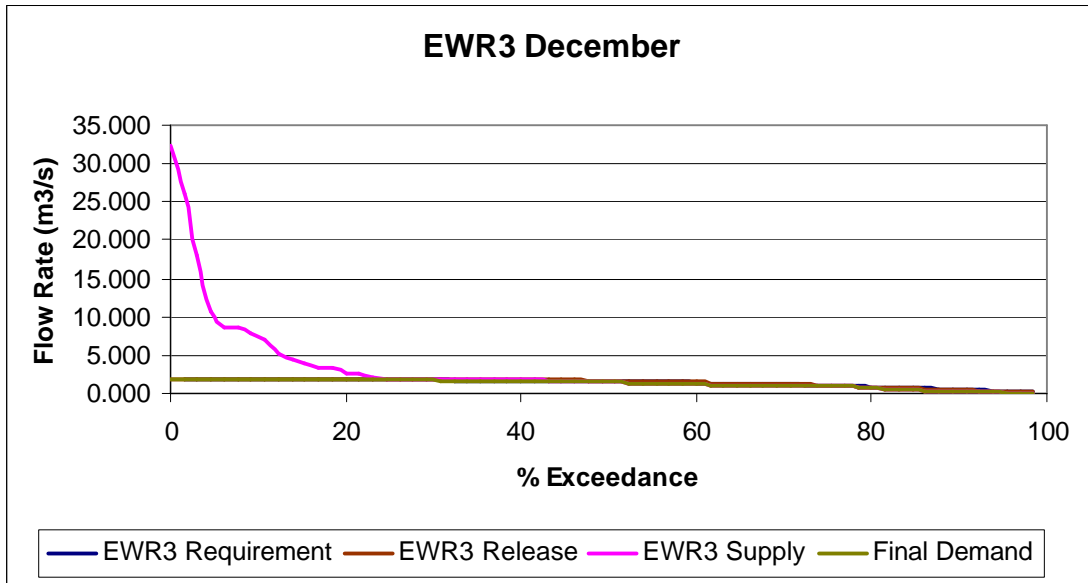

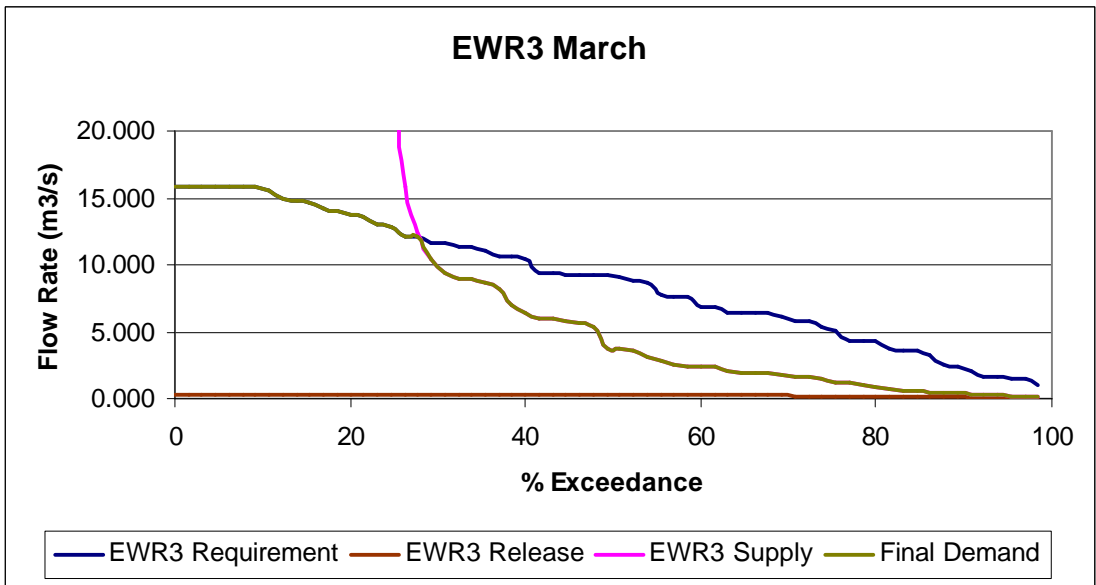
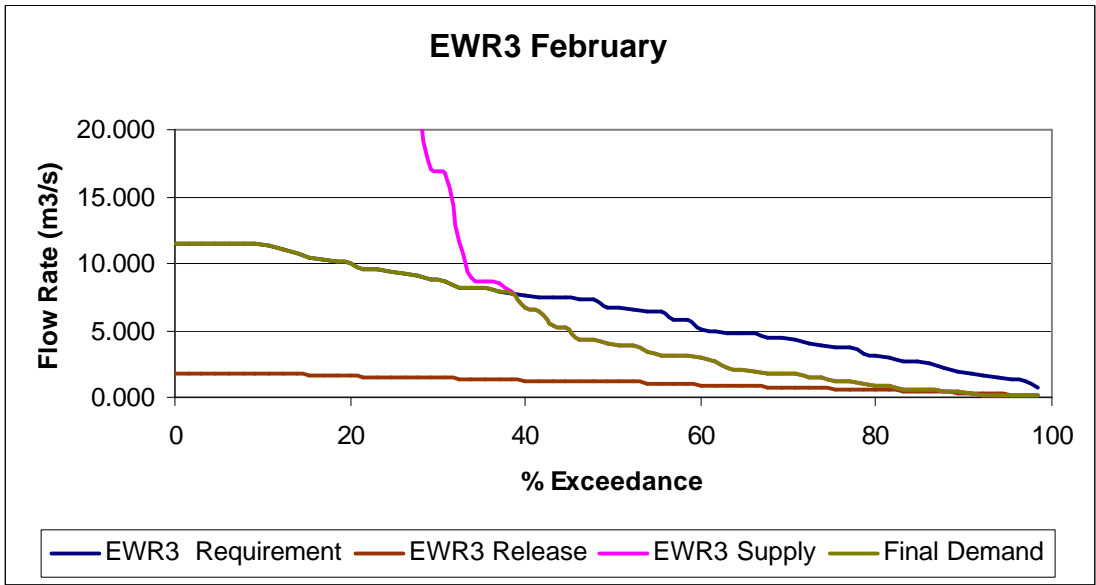

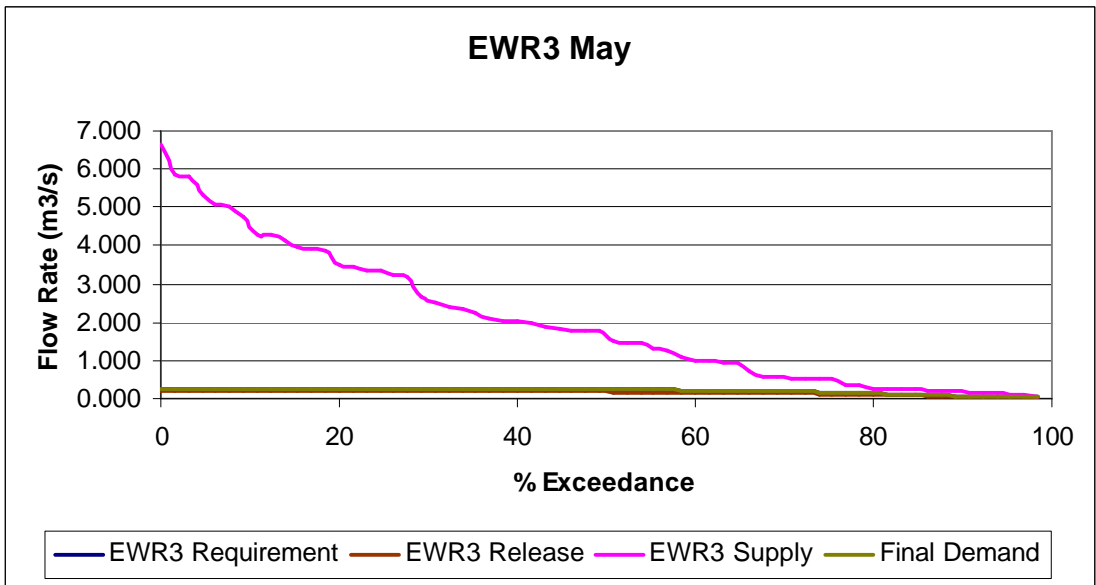
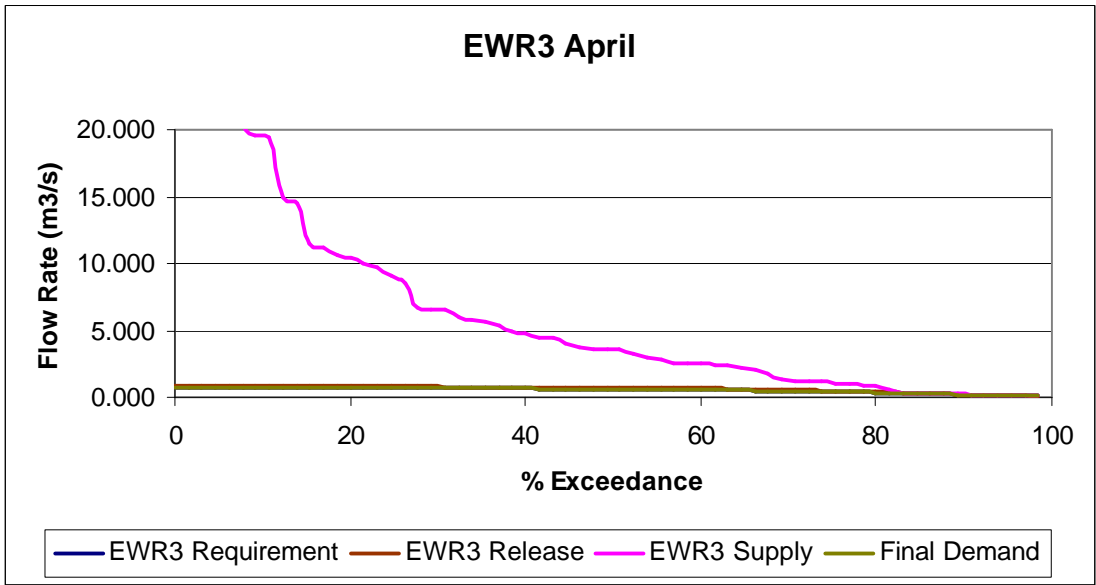

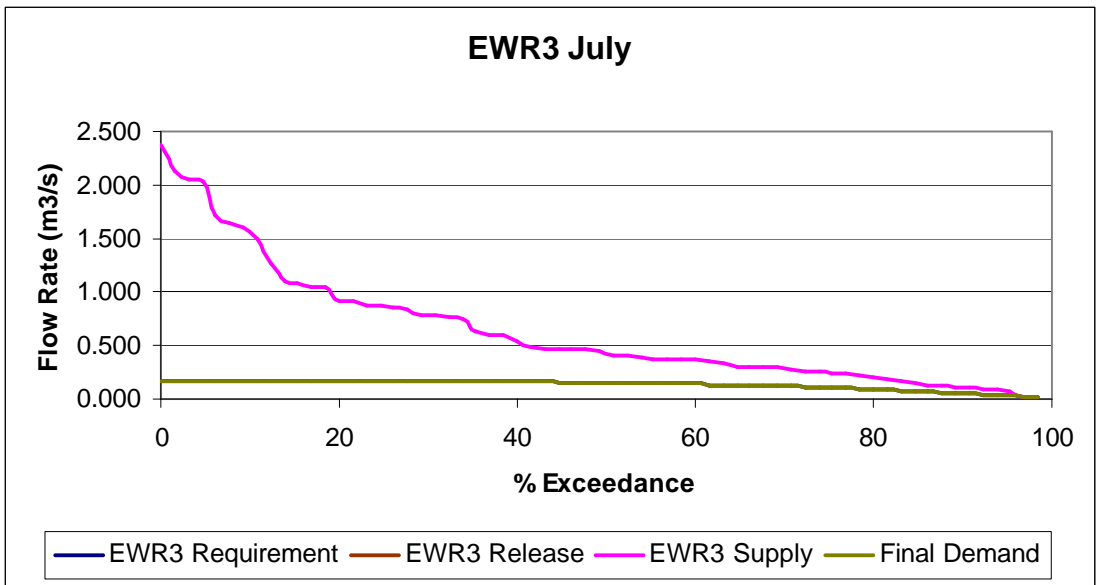
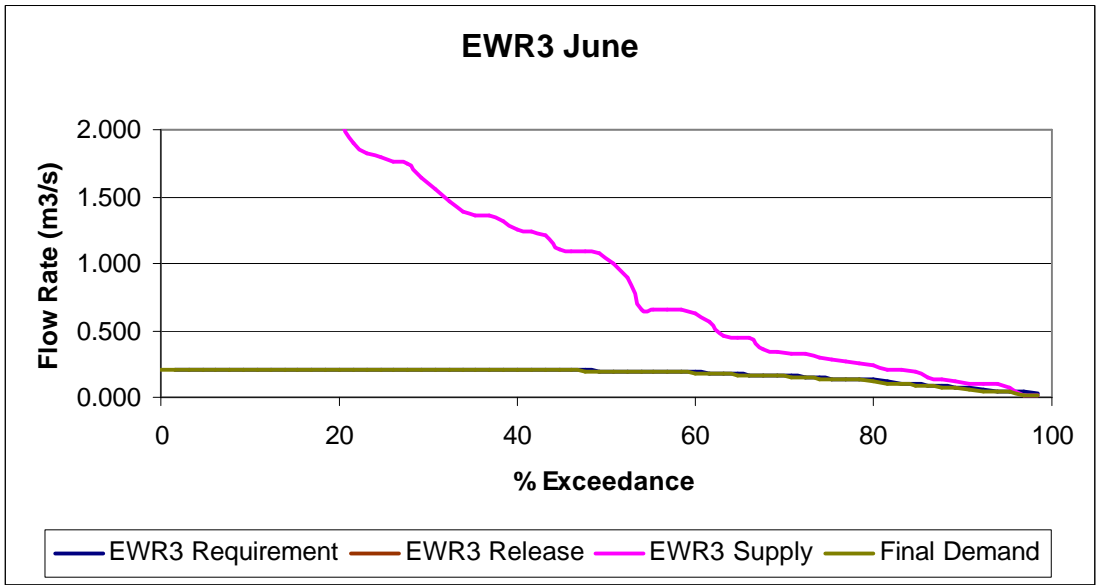

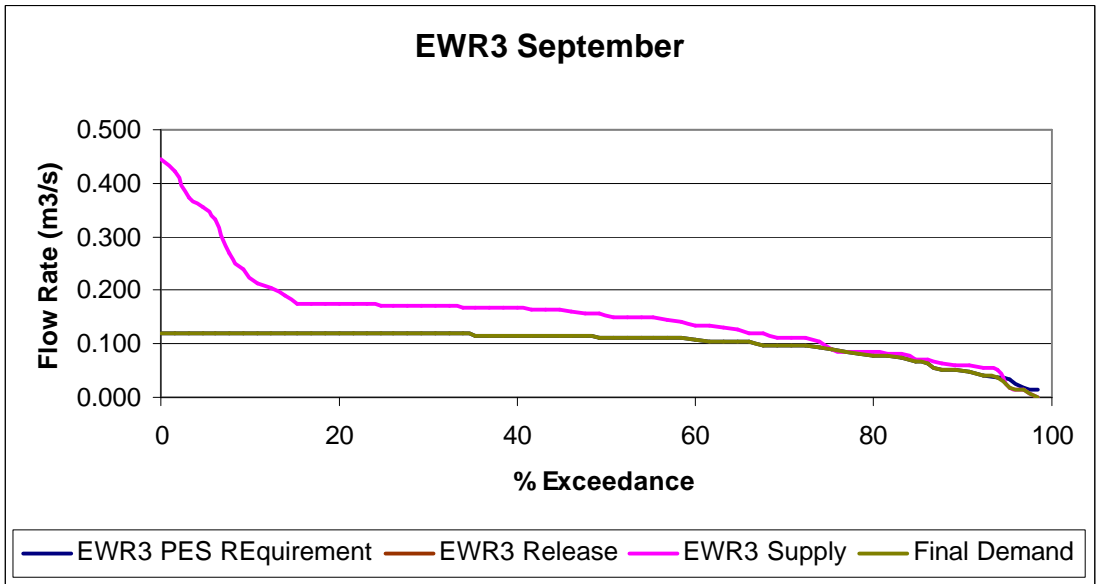
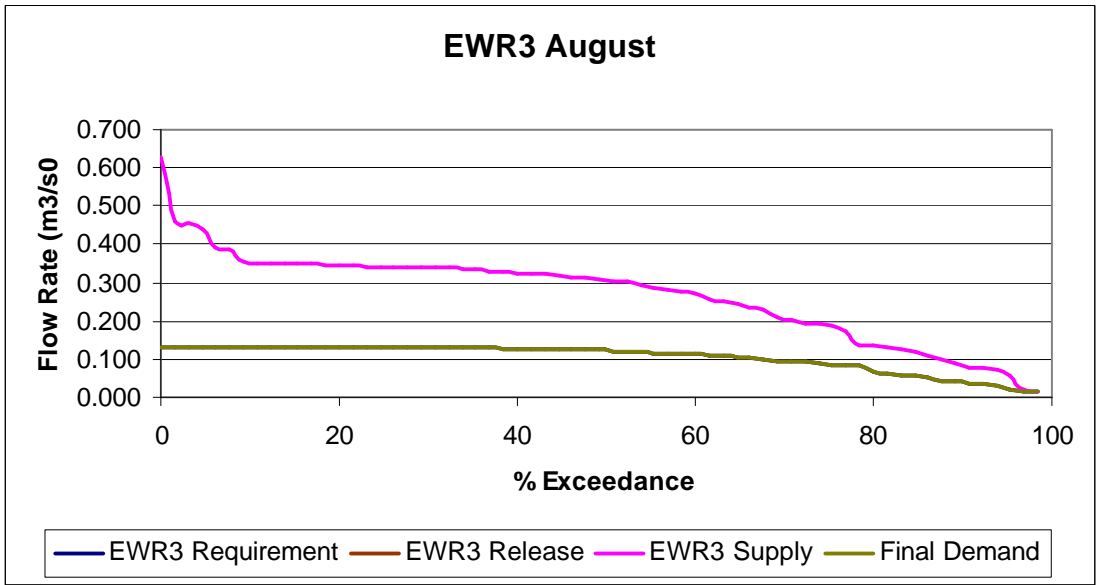

EWR4 October

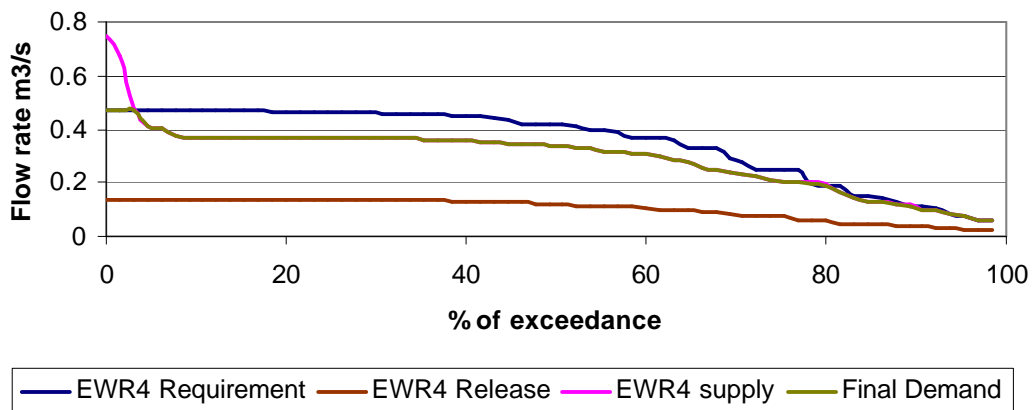

EWR4 November

